



## Department of Energy

Portsmouth/Paducah Project Office  
1017 Majestic Drive, Suite 200  
Lexington, Kentucky 40513  
(859) 219-4000

**FEB 08 2017**

Mr. Brian Begley  
Federal Facility Agreement Manager  
Division of Waste Management  
Kentucky Department for Environmental Protection  
300 Sower Blvd., 2nd Floor  
Frankfort, Kentucky 40601

PPPO-02-4022215-17

Ms. Julie Corkran  
Federal Facility Agreement Manager  
U.S. Environmental Protection Agency, Region 4  
61 Forsyth Street  
Atlanta, Georgia 30303

Dear Mr. Begley and Ms. Corkran:

**REMOVAL ACTION REPORT FOR SOLID WASTE MANAGEMENT UNIT 27 AT  
THE PADUCAH GASEOUS DIFFUSION PLANT, PADUCAH, KENTUCKY,  
DOE/LX/07-2411&D1**

Please find enclosed for your review and approval the *Removal Action Report for Solid Waste Management Unit 27 at the Paducah Gaseous Diffusion Plant, Paducah, Kentucky, DOE/LX/07-2411&D1*. This secondary document follows the outline and content for Removal Action Reports that was developed and agreed to by the Paducah Federal Facility Agreement (FFA) Managers in April 2010.

In accordance with Section XX.G.2 of the FFA, the subject document has a 90-day review and comment period.

If you have any questions or require additional information, please contact April Ladd at (270) 441-6843.

Sincerely,

A handwritten signature in black ink, appearing to read "Tracey Duncan".

Tracey Duncan  
Federal Facility Agreement Manager  
Portsmouth/Paducah Project Office

Enclosure:

RAR for the SWMU 27 at the PGDP, DOE/LX/07-2411&D1

e-copy w/enclosure:

amy.rodgers@ffspaducah, FFS/Kevil  
april.ladd@lex.doe.gov, PPPO/PAD  
april.webb@ky.gov, KDEP/Frankfort  
brian.begley@ky.gov, KDEP/Frankfort  
bwhatton@tva.gov, TVA/Paducah  
christopher.jung@ky.gov, KDEP/Frankfort  
corkran.julie@epa.gov, EPA/Atlanta  
ffscorrespondence@ffspaducah.com, FFS/Kevil  
gaye.brewer@ky.gov, KDEP/PAD  
hjlawrence@tva.gov, TVA/Paducah  
jana.white@ffspaducah, PPPO/PAD  
jennifer.woodard@lex.doe.gov, PPPO/PAD  
karen.walker@ffspaducah.com, FFS/Kevil  
kelly.layne@ffspaducah.com, FFS/Kevil  
kim.knerr@lex.doe.gov, PPPO/PAD  
lbirk@techlawinc.com, EPA/Chicago  
leo.williamson@ky.gov, KDEP/Frankfort  
mike.guffey@ky.gov, KDEP/Frankfort  
myrna.redfield@ffspaducah.com, FFS/Kevil  
nathan.garner@ky.gov, KYRHB/Frankfort  
pad.rmc@swiftstaley.com, SSI/Kevil  
richards.jon@epamail.epa.gov, EPA/Atlanta  
rkdehart@tva.gov, TVA/Paducah  
stephaniec.brock@ky.gov, KYRHB/Frankfort  
tracey.duncan@lex.doe.gov, PPPO/PAD

**REMOVAL ACTION REPORT FOR  
SOLID WASTE MANAGEMENT UNIT 27  
AT THE PADUCAH GASEOUS DIFFUSION PLANT,  
PADUCAH, KENTUCKY**

**Description of the Removal Action Implemented**

During the field activities of the *Addendum to the Work Plan for Soils Operable Unit Remedial Investigation/Feasibility Study at the Paducah Gaseous Diffusion Plant, Paducah, Kentucky, Remedial Investigation 2, Sampling and Analysis Plan*, DOE/LX/07-0120&D2/R2/A1 (DOE 2014), an underground acid neutralization tank (C-722), which is designated as Solid Waste Management Unit (SWMU) 27, was opened and observed to contain liquid and sludge. The liquid and sludge phases were sampled. Data from the sampling event identified Comprehensive Environmental Response, Compensation, and Liability Act (CERCLA) hazardous substances, including Toxic Substances Control Act-regulated constituents, Resource Conservation and Recovery Act hazardous constituents, and radionuclides contained within the SWMU 27 underground tank.

Although no actual releases of hazardous substances from the tank were documented, DOE determined, pursuant to the National Contingency Plan (NCP), 40 *CFR* § 300.415(b)(2), that a Time-Critical Removal Action (TCRA) was appropriate considering the age and the unknown condition of the SWMU 27 underground tank that could pose a threat of release of hazardous substances. On February 8, 2016, DOE proposed implementing a TCRA to remove the liquid and sludge from the tank and fill the tank with flowable fill. The U.S. Environmental Protection Agency (EPA) and the Kentucky Department for Environmental Protection (KDEP) accepted the proposal on February 12, 2016. On September 9, 2016, EPA and the KDEP approved DOE's *Removal Notification for Solid Waste Management Unit 27 at the Paducah Gaseous Diffusion Plant, Paducah, Kentucky*, DOE/LX/07-2406&D2, (RN) (DOE 2016), which specified the proposed actions to complete the TCRA.

The removal action for SWMU 27 was conducted as a CERCLA TCRA pursuant to the U.S. Department of Energy's (DOE's) authority under Executive Order 12580 and in accordance with the *Federal Facility Agreement for the Paducah Gaseous Diffusion Plant* (FFA) (EPA 1998), Section X.D., Time-Critical Removal Actions, and the NCP, 40 *CFR* Part 300.

**SWMU 27 Overview**

The SWMU 27 underground tank is located immediately adjacent to the northeast corner of the C-720 facility, which is an occupied structure. The underground tank, identified as C-722, was intended as an auxiliary facility to the instrument shop, which is located in the northeast corner of the first floor of the C-720 facility (see Figure 1). Engineering drawings show that four acid sinks drained from the instrument shop and flowed into the tank. The tank originally was constructed with one effluent line, exiting the north side of the tank; that line discharged to the site's storm water system, which eventually

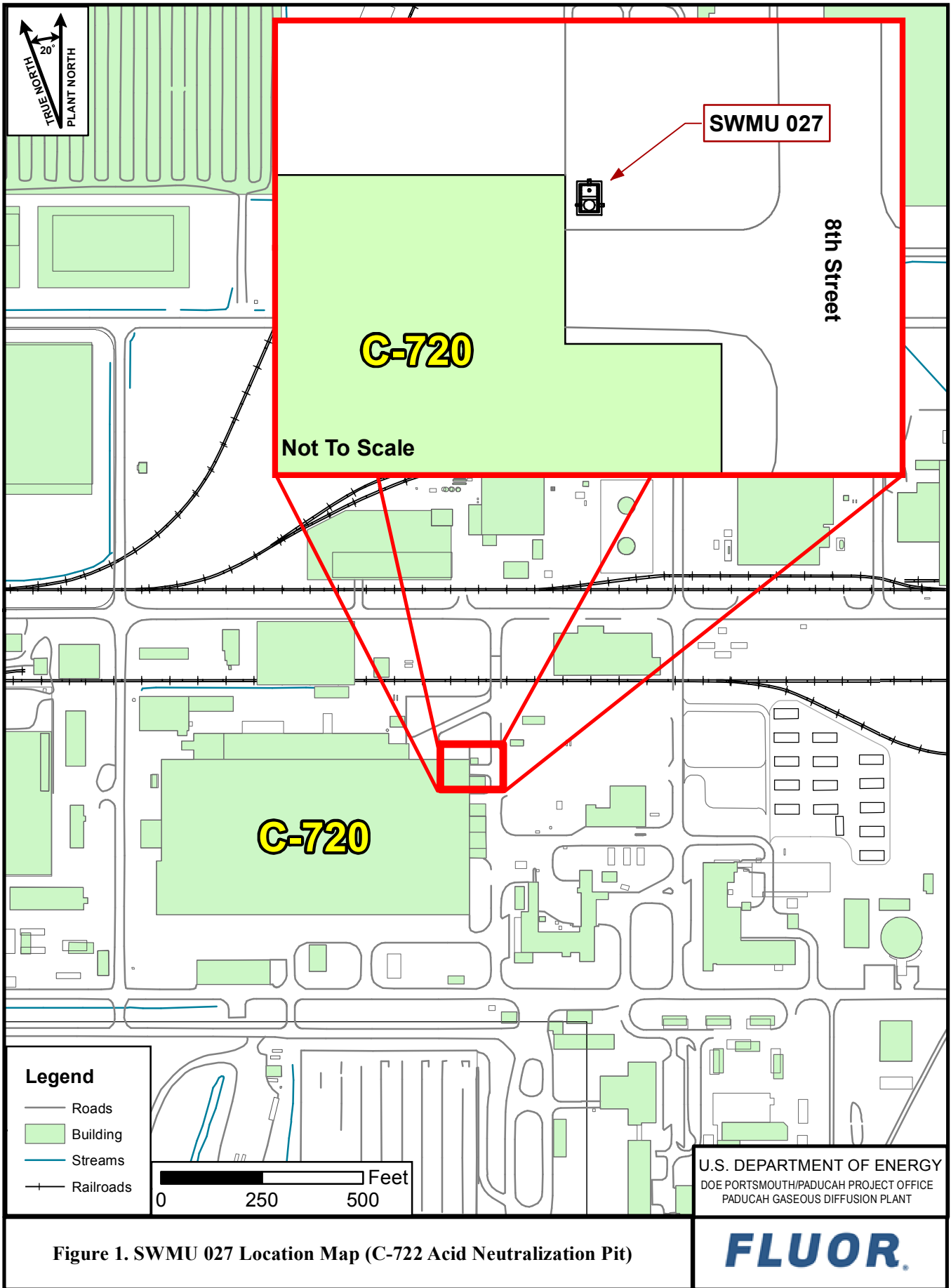

Figure 1. SWMU 027 Location Map (C-722 Acid Neutralization Pit)

discharged along with other plant effluent water into Bayou Creek at Outfall 008. During what was known as the waste heat utilization project during the late 1970s, it appears the original effluent line from the tank was blocked, and a new effluent line was added. The new effluent line exited the east side of the tank; however, the effluent water's path to the site's storm water system, with eventual discharge to Outfall 008, remained relatively unchanged. The tank also had a vent line that ran from the tank to the roof of the C-720 facility.

Constructed in the early 1950s, the underground tank is a concrete structure with internal dimensions of approximately 5.2 ft × 6.2 ft × 3.9 ft (height × length × width). These dimensions equate to approximately 124.3 ft<sup>3</sup>. There is an internal baffle wall suspended within the tank, which has a volume of approximately 19.5 ft<sup>3</sup>. By subtracting the volume of the baffle wall, the volume of the tank was determined to be approximately 104.8 ft<sup>3</sup>.

Additionally, there is a manhole access to the tank. The manhole access dimensions are approximately 2.8 ft × 4.3 ft (diameter × height), which results in a volume of approximately 25 ft<sup>3</sup>. Given these dimensions, the overall volume of the tank was approximately 129.8 ft<sup>3</sup>. Figure 2 provides a detailed diagram of the underground tank.

The western side of the tank is located approximately 2.5 ft from the northeast corner of the C-720 facility. The concrete structure is lined with an acid-resistant, laminated membrane and acid-resistant bricks.

### **Summary of Results**

Implementation of the SWMU 27 TCRA was completed successfully without any incidents that jeopardized worker safety and in compliance with applicable or relevant and appropriate requirements (ARARs). The TCRA involved removing the liquid and sludge phases to the extent practicable; filling the tank with flowable fill, which plugged the influent and effluent lines; and capping the tank's vent line located on the roof of C-720. At the conclusion of these activities, the tank was left in abandoned condition. Any additional actions for the tank structure and/or surrounding soils will be addressed separately under the Soils and Slabs Operable Unit.

Waste was segregated into three separate waste streams: liquid, sludge, and "secondary waste," consisting of used pumps, hoses, personal protective equipment (PPE), contaminated tools, etc. The sludge phase was containerized and shipped to Perma-Fix in Tennessee for disposition. The liquid and "secondary waste" was containerized and shipped to EnergySolutions in Utah for disposition.

### **Removal Action Initiation**

The TCRA began on September 13, 2016, four days after EPA and KDEP approved the RN. KDEP representatives were present to observe key activities, as stated in the RN. The initial activities included the mobilization of equipment and securing and preparing the work zone. The work zone was secured from site workers not involved in the project. Because SWMU 27 was in close proximity to an occupied building, those workers who routinely worked in and around the C-720 facility were briefed on the hazards and boundaries associated with the project. Workers who occupied the northeast corner of C-720 were evacuated from the facility during implementation of TCRA fieldwork.

**NOTES:**

- ① ALL DIMENSIONS ANNOTATED IN THIS DRAWING ARE ROUNDED TO THE NEAREST 1/4".
- ② DIMENSIONS REFERENCED IN THIS DRAWING ARE FOR INFORMATIONAL PURPOSES ONLY. REFER TO DRAWINGS E3-8-M AND E3-43-A FOR "AS-BUILT" DIMENSIONS.
- ③ LOCATION AND SIZE (APPROXIMATELY 8"Ø) FOR LINE ON EAST SIDE OF PIT SHOWN IN THIS FIGURE ARE ESTIMATED. NO DRAWINGS AVAILABLE TO INDICATE ACTUAL SIZE AND LOCATION. LINE ASSUMED TO REPLACE 8"Ø CLAY TILE ON NORTH SIDE OF PIT AFTER WASTE HEAT VALVE PIT WAS INSTALLED.

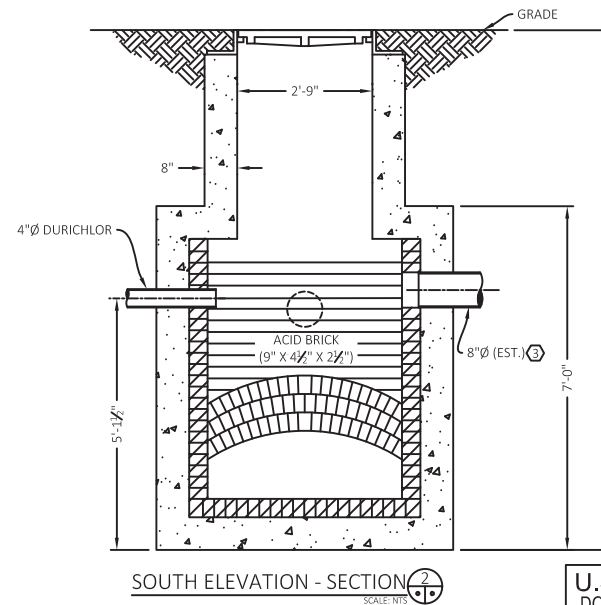
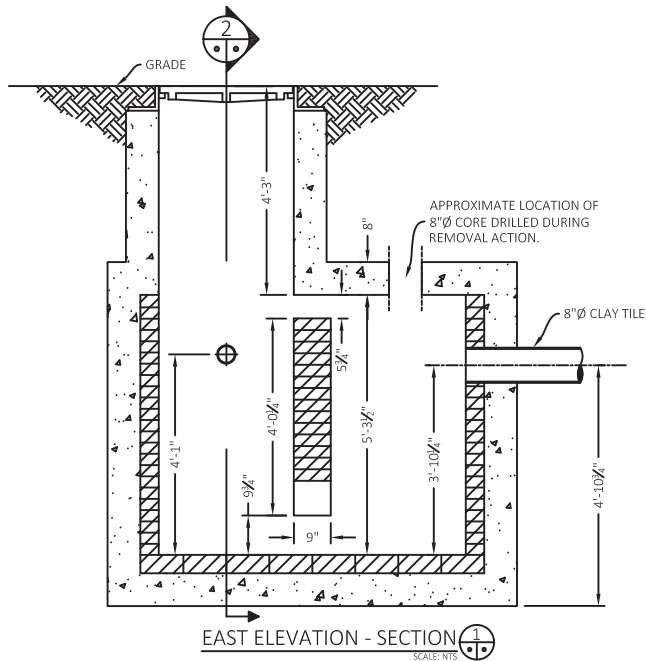
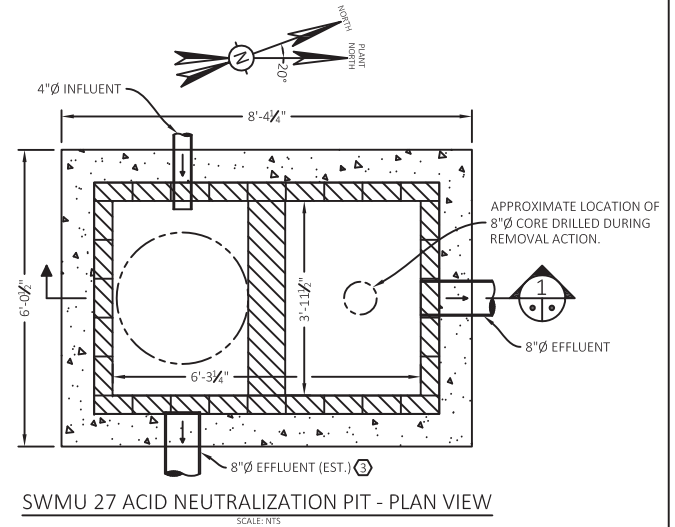

U.S. DEPARTMENT OF ENERGY  
DOE PORTSMOUTH/PADUCAH PROJECT OFFICE  
PADUCAH GASEOUS DIFFUSION PLANT

**FLUOR**

**Figure 2. SWMU 27 Acid Neutralization Pit Details**

## **Opening of the Tank**

The tank was designed with one opening (manhole), located on the south side of the baffled wall that is suspended by the walls of the tank (i.e., the baffled wall does not rest on the floor of the tank nor does the wall reach the top of the tank). A portion of the top of the underground tank, north of the manhole, was accessed by excavation of approximately 3.5 ft of soil and gravel. This allowed another opening to be core drilled on the north side of the baffled wall (see Figure 2) to better facilitate the removal of the liquid and sludge, filling of flowable fill, and use of a borescope. Air monitoring was used to identify and quantify airborne levels of hazardous substances to ensure the level of PPE being used was sufficient to protect workers from human health hazards.

## **Liquid and Sludge Removal**

The liquid and sludge identified as part of the SWMU 27 TCRA were removed to the extent practicable following the approved strategy presented in the SWMU 27 RN (DOE 2016). Additional steps also were taken as part of the fieldwork, as outlined below.

Hose(s) attached to pumps were lowered into the tank with minimal disturbance to keep the two phases of liquid and sludge separated. To the extent possible, the phases were removed separately to minimize homogenization of the liquid phase with the more contaminated sludge phase.

An air-operated, double-diaphragm pump (Pump A) was used to remove the liquid phase and sludge phase until Pump A could not maintain prime. Pump B, a sludge pump that delivers high-pressure water through the body of the pump creating a vacuum (venturi action) at the intake of the nozzle, was used to remove the remaining sludge that Pump A could not remove. To minimize additional creation of waste by adding water through Pump B, it was determined, as outlined in the RN, that 7 minutes (3.5 minutes per each side of baffle wall) was adequate to allow a full sweep of the tank.

On September 14, 2016, Pump A was used to remove the approximately 400 gal of liquid phase, which was pumped into totes. Pump A then was used to pump sludge until Pump A was not able to maintain prime. At this time, Pump B then was operated for 7 minutes (3½ minutes per side). A total of two drums (55 gal each) of sludge material was collected. The completion criteria specified in the RN were met at this point.

On September 15, 2016, DOE chose to implement additional steps using Pumps A and B. It was determined that Pump A would be able to remove additional liquid and/or sludge after initial disturbance of sludge from Pump B. Pump A was used until the pump no longer maintained prime, removing approximately one and one-third 55-gal drums of liquid and/or sludge, after which Pump B again was used for 7 minutes (3½ minutes per side) to remove an additional one and one-third drums of sludge.

On September 16, 2016, Pumps A and B were operated for another attempt at additional sludge removal. Pump A was not able to initiate prime, at which point the field crew switched to Pump B. Pump B was able to return only clean water (introduced by the pump), and no additional sludge, adding approximately one-third drum of clean water to the partially filled drum from the prior day's activities. The tank was inspected at this point with the borescope to document the tank's final condition prior to filling the tank with flowable fill. The video of this borescope inspection was reviewed by the project team and representatives of KDEP. Based on the analysis of the video and the known internal dimensions of the tank, it was determined that approximately 5 inches of sludge (approximately 80 gal, assuming the entire tank floor was covered by 5 inches of liquid and sludge) could not be removed and remained in the tank when flowable fill was added.

### **Influent and Effluent Line Isolation**

An initial lift of flowable fill was poured into the underground tank, stopping at the top of the influent and effluent lines, on September 16, 2016. This allowed the flowable fill to solidify without flowing laterally into the lines. The flowable fill was allowed to solidify for approximately two days. On September 19, 2016, additional flowable fill was added to the top of the tank openings. On September 21, 2016, the vent line on the C-720 Building was capped using a Victaulic fitting and bull plug (i.e., coupling and a close-end plug).

### **Disposition of Waste and Site Cleanup**

The soil and gravel removed at the onset of the fieldwork activities were monitored for radiological contaminants and determined to be suitable for use as backfill. The soil and gravel were stored in a covered dump hopper and were used to backfill the excavation.

Liquid, sludge, and secondary waste generated as part of this TCRA were containerized and shipped to acceptable off-site facilities for disposition. Approximately 275 gal of sludge was packaged and shipped to Perma-Fix in Tennessee. Approximately 400 gal of liquid was packaged into two totes and shipped to EnergySolutions in Utah, along with two ST-90 containers filled with the secondary waste.

### **Contamination Control**

The SWMU 27 TCRA activities were performed near potential radiological contaminated equipment and near the SWMU 27 tank that contained radiologically contaminated material. Worker protection included engineering controls, administrative controls, and PPE. Examples of these controls included radiological work permits, workforce training, PPE, and monitoring of personnel and equipment before exiting the work area.

No personnel contamination events occurred throughout the TCRA activities at SWMU 27. Material and equipment used during removal activities were monitored by radiological control personnel. Items found with radiological contamination present were either decontaminated or disposed of as radiologically contaminated waste.

### **Personal and Area Air Monitoring**

Industrial safety (IS)/industrial hygiene (IH) specialists used environmental monitoring and analytical methods to detect the extent of worker exposure and employed engineering, work practice controls, and other methods to control potential health hazards.

IS/IH specialists supported the work activities through daily oversight to identify hazards, establish controls, and monitor work to ensure the work was performed in accordance with established controls.

During the removal of SWMU 27 tank contents, IS/IH specialists were present to provide safety and health coverage for employees performing the content removal fieldwork.

IH monitoring for the SWMU 27 project included sampling for mercury and volatile organic compounds, primarily trichloroethene and trichloroethane. A total of 147 IS/IH samples was collected, consisting of both personal and area IH samples. All sample results were found to be below the action limits.<sup>1</sup>

---

<sup>1</sup> Action limits for the chemicals monitored were administrative control limits set at one-half of the applicable 10-hour time-weighted average (Occupational Safety and Health Administration permissible exposure limits).



**Summary of Problems Encountered, including Deviations**

During removal of the SWMU 27 tank contents, changes in field conditions led to the use of Pumps A and B beyond the completion criteria set forth in the RN. The pumping activities that took place on September 15 and 16, 2016, were captured as field changes to the project task instructions.

There was debris within the tank (i.e., brick and lumber) that could not be removed with the use of Pumps A and B. This debris was left in the tank, and the tank was filled with flowable fill.

**Summary of Accomplishments and/or Effectiveness of the Removal Action**

A total of 400 gal of liquid was pumped into two totes, with a capacity of 330 gal per tote (one full tote and one partially filled tote). A total of five drums (55 gal per drum) of sludge was removed from the tank, equating to approximately 275 gal. The flowable fill added was successful in plugging the influent and effluent lines in the tank. The remaining water left in the tank was absorbed with the addition of flowable fill. The approximate 80 gal of sludge remaining on the bottom of tank was contained by the flowable fill and isolated within the tank.

**Timeline for Completion**

A timeline of activities is provided below in Table 1. Borescope videos identified in Table 1 are included in compact disc format in the appendix of this report.

**Table 1. Timeline for Completion**

<b>Date</b>	<b>Activity</b>
9/13/2016	Mobilized equipment. Setup Criticality Accident Alarm System and Hazardous Waste Operations and Emergency Response boundaries. Assembled pumps. Excavated soil to uncover top of tank and performed core drilling north of the baffled wall.
9/14/2016	Used borescope to video inside of tank before start of pumping (see Appendix, <i>SWMU 27 Initial</i> ).
9/14/2016	Used Pump A to remove approximately 400 gal of liquid.
9/14/2016	Used borescope to video inside of tank after use of Pump A (see Appendix, <i>SWMU 27 Pit Post Pump A, SWMU 27 Manhole Post Pump A</i> ).
9/14/2016	Used Pump A (unable to maintain prime) and Pump B for 7 minutes and removed two drums (drums 1 and 2) of sludge.
9/14/2016	Used borescope to video inside of tank after use of Pump A and Pump B (see Appendix, <i>SWMU 27 Manhole Post Pump B</i> ).
9/15/2016	Performed sludge removal with Pump A, which yielded approximately one and one-third drums (drum 3 and partial drum 4). Switched to Pump B for 7 minutes and removed one and one-third drums (filled drum 4 and partial drum 5).
9/15/2016	Used borescope to video inside of tank after use of Pump A and Pump B (see Appendix, <i>SWMU 27 Pit Post Pump A Sludge and SWMU 27 Manhole Post Pump A Sludge</i> ).
9/16/2016	Attempted additional sludge removal with Pump A and B. Pump A would not maintain prime. Pump B would return only clean water (as part of pump design) and no sludge, approximately one-third drum added to drum 5.
9/16/2016	Used borescope to video final condition of the tank before addition of flowable fill (see Appendix, <i>SWMU 27 Pit Final and SWMU 27 Manhole Final</i> ).
9/16/2016	Flowable fill added up to top of influent/effluent lines and allowed to solidify over weekend (9/17/2016–9/18/2016).
9/19/2016	Remainder of flowable fill added to the top of tank opening. Soil excavated for core drilling was placed back to grade.
9/19/2016	Decontaminated all containers and relocated them to on-site storage area C-752.

**Table 1. Timeline for Completion (Continued)**

<b>Date</b>	<b>Activity</b>
9/19/2016	Initiated demobilization of equipment.
9/20/2016	Performed site cleanup and more demobilization activities.
9/21/2016	Completed demobilization and cleanup. Placed sign noting that the tank is abandoned in place on manhole lid with adhesive; silicone applied around the lid to hold it in place and seal it.
9/21/2016	Capped vent line on roof of C-720 Building.
9/25/2016	Sampled liquid and sludge.
10/26/2016	Sludge shipped to Perma-Fix for treatment and disposal.
10/27/2016	Shipped water and secondary waste to EnergySolutions for treatment and disposal.

**Summary of the Project Cost**

The cost of implementing this TCRA, including packaging, transportation, and disposal of waste, was \$819,000 (current estimate at completion).

**References**

DOE (U.S. Department of Energy) 2014. *Addendum to the Work Plan for Soils Operable Unit Remedial Investigation/Feasibility Study at the Paducah Gaseous Diffusion Plant, Paducah, Kentucky, Remedial Investigation 2, Sampling and Analysis Plan*, DOE/LX/07-0120&D2/R2/A1, U.S. Department of Energy, Paducah, KY, August.

DOE 2016. *Removal Notification for Solid Waste Management Unit 27 at the Paducah Gaseous Diffusion Plant, Paducah, Kentucky*, DOE/LX/07-2406&D2, U.S. Department of Energy, Paducah, KY, September.

EPA (U.S. Environmental Protection Agency) 1998. *Federal Facility Agreement for the Paducah Gaseous Diffusion Plant*, U.S. Environmental Protection Agency, Atlanta, GA, February 13.

**APPENDIX**

**SWMU 27 BORESCOPE VIDEOS**

**APPENDIX**

**SWMU 27 BORESCOPE VIDEOS (CD)**