



## Department of Energy

Portsmouth/Paducah Project Office  
1017 Majestic Drive, Suite 200  
Lexington, Kentucky 40513  
(859) 219-4000

**JAN 31 2011**

Mr. Wm. Turpin Ballard, Remedial Project Manager  
U.S. Environmental Protection Agency, Region 4  
Federal Facilities Branch  
61 Forsyth Street  
Atlanta, Georgia 30303

PPPO-02-1118463-11

Mr. Edward Winner, FFA Manager  
Kentucky Department for Environmental Protection  
Division of Waste Management  
200 Fair Oaks Lane, 2<sup>nd</sup> Floor  
Frankfort, Kentucky 40601

Dear Mr. Ballard and Mr. Winner:

**REVISED FOCUSED FEASIBILITY STUDY FOR SOLID WASTE MANAGEMENT UNITS 1, 211A, AND 211B VOLATILE ORGANIC COMPOUND SOURCES TO THE SOUTHWEST GROUNDWATER PLUME AT THE PADUCAH GASEOUS DIFFUSION PLANT, PADUCAH, KENTUCKY (DOE/LX/07-0362&D1)**

Please find enclosed the certified D1 *Revised Focused Feasibility Study for Solid Waste Management Units 1, 211A, and 211B Volatile Organic Compound Sources to the Southwest Groundwater Plume at the Paducah Gaseous Diffusion Plant, Paducah, Kentucky, DOE/LX/07-0362&D1*. Comments are requested no later than March 17, 2011.

If you have any questions or require additional information, please contact David Dollins at (270) 441-6819.

Sincerely,

A handwritten signature in black ink, appearing to read "Reinhard Knerr".

Reinhard Knerr  
Paducah Site Lead  
Portsmouth/Paducah Project Office

Enclosures:

1. Certification Page
2. Revised FFS

cc w/enclosures:  
DMC/Kevil

e-copy w/enclosures:

alicia.scott@lataky.com, LATA/Kevil  
ballard.turpin@epa.gov, EPA/Atlanta  
barbara.mazurowski@lataky.com, LATA/Kevil  
brandy.mitchell@lataky.com, LATA/Kevil  
bryan.clayton@lataky.com, LATA/Kevil  
christa.dailey@lex.doe.gov, PRC/PAD  
christie.lamb@lataky.com, LATA/Kevil  
craig.jones@lataky.com, LATA/Kevil  
dave.dollins@lex.doe.gov, PPPO/PAD  
edward.winner@ky.gov, KDEP/Frankfort  
gaye.brewer@ky.gov, KDEP/PAD  
jeff.carman@lataky.com, LATA/Kevil  
jeffrey.gibson@ky.gov, KDEP/Frankfort  
leo.williamson@ky.gov, KDEP/Frankfort  
rachel.blumenfeld@lex.doe.gov, PPPO/LEX  
rebecca.wren@lex.doe.gov, PRC/PAD  
reinhard.knerr@lex.doe.gov, PPPO/PAD  
rich.bonczek@lex.doe.gov, PPPO/LEX  
rob.seifert@lex.doe.gov, PPPO/PAD  
todd.mullins@ky.gov, KDEP/Frankfort  
tufts.jennifer@epa.gov, EPA/Atlanta  
william.creech@lex.doe.gov, PPPO/LEX

## CERTIFICATION

Document Identification: ***Revised Focused Feasibility Study for Solid Waste Management Units 1, 211A, and 211B Volatile Organic Compound Sources for the Southwest Groundwater Plume at the Paducah Gaseous Diffusion Plant, Paducah, Kentucky, DOE/LX/07-0362&D1, Primary Document***

I certify under penalty of law that this document and all attachments were prepared under my direction or supervision in accordance with a system designed to assure that qualified personnel properly gather and evaluate the information submitted. Based on my inquiry of the person or persons directly responsible for gathering the information, the information submitted is, to the best of my knowledge and belief, true, accurate, and complete. I am aware that there are significant penalties for submitting false information, including the possibility of fine and imprisonment for knowing violations.

LATA Environmental Services of Kentucky, LLC  
Operator

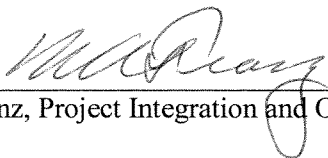

Bill Franz, Project Integration and Operations Manager

1/31/11

Date Signed

I certify under penalty of law that this document and all attachments were prepared under my direction or supervision in accordance with a system designed to assure that qualified personnel properly gather and evaluate the information submitted. Based on my inquiry of the person or persons directly responsible for gathering the information, the information submitted is, to the best of my knowledge and belief, true, accurate, and complete. I am aware that there are significant penalties for submitting false information, including the possibility of fine and imprisonment for knowing violations.

U.S. Department of Energy (DOE)  
Owner



Reinhard Knerr, Paducah Site Lead  
Portsmouth/Paducah Project Office

1/31/11

Date Signed

**DOE/LX/07-0362&D1  
Primary Document**

**Revised Focused Feasibility Study  
for Solid Waste Management Units 1, 211A, and 211B  
Volatile Organic Compound Sources  
for the Southwest Groundwater Plume  
at the Paducah Gaseous Diffusion Plant,  
Paducah, Kentucky**



**CLEARED FOR PUBLIC RELEASE**



**DOE/LX/07-0362&D1  
Primary Document**

**Revised Focused Feasibility Study  
for Solid Waste Management Units 1, 211A, and 211B  
Volatile Organic Compound Sources  
for the Southwest Groundwater Plume  
at the Paducah Gaseous Diffusion Plant,  
Paducah, Kentucky**

Date Issued—January 2011

U.S. DEPARTMENT OF ENERGY  
Office of Environmental Management

Prepared by  
LATA Environmental Services of Kentucky, LLC  
Managing the  
Environmental Remediation Activities at the  
Paducah Gaseous Diffusion Plant  
under contract # DE-AC30-10CC40020

**CLEARED FOR PUBLIC RELEASE**

**THIS PAGE INTENTIONALLY LEFT BLANK**

## PREFACE

This *Revised Focused Feasibility Study for Solid Waste Management Units 1, 211A, and 211B Volatile Organic Compound Sources for the Southwest Groundwater Plume at the Paducah Gaseous Diffusion Plant, Paducah, Kentucky*, DOE/LX/07-0362&D1, was prepared to develop and evaluate remedial alternatives for potential application at the U.S. Department of Energy's (DOE's) Paducah Gaseous Diffusion Plant. This document has been developed as a revision to the *Focused Feasibility Study for the Southwest Groundwater Plume Volatile Organic Compound Sources (Oil Landfarm and C-720 Northeast and Southeast Sites) at the Paducah Gaseous Diffusion Plant, Paducah, Kentucky* (DOE 2010a). Revisions include the presentation of additional alternatives, which were developed and evaluated as a result of performance data, actual project cost, and implementation information being generated from Phase I of the C-400 Interim Remedial Action.

This work was prepared in accordance with the requirements of the *Federal Facility Agreement for the Paducah Gaseous Diffusion Plant* (FFA) (EPA 1998), the "Resolution of the Environmental Protection Agency Letter of Non-Concurrence for the Site Investigation Report for the Southwest Plume at the Paducah Gaseous Diffusion Plant, Paducah, Kentucky, DOE/OR/07-2180&D2/R1, and Notice of Informal Dispute Dated November 30, 2007, McCracken County, Kentucky KY 8-890-008-982" (referred to as the Resolution) (EPA 2008a), and the *Memorandum of Agreement for Resolution of Informal Dispute for the Focused Feasibility Study for the Southwest Plume Volatile Organic Compound Sources Oil Landfarm and C-720 Northeast and Southeast Sites) at the Paducah Gaseous Diffusion Plant, Paducah, KY* (EPA 2010).

In accordance with Section IV of the FFA, this integrated technical document was developed to satisfy applicable requirements of the Comprehensive Environmental Response, Compensation, and Liability Act (CERCLA) (42 *USC* 9601 *et seq.* 1980) and the Resource Conservation and Recovery Act (42 *USC* 6901 *et seq.* 1976). As such, the phases of the investigation process are referenced by CERCLA terminology within this document to reduce the potential for confusion.



**THIS PAGE INTENTIONALLY LEFT BLANK**

# CONTENTS

PREFACE.....	iii
TABLES .....	vii
FIGURES.....	ix
ACRONYMS.....	xi
EXECUTIVE SUMMARY .....	ES-1
1. INTRODUCTION .....	1-1
1.1 PURPOSE AND ORGANIZATION.....	1-1
1.2 BACKGROUND INFORMATION .....	1-2
1.2.1 Site Description.....	1-2
1.2.2 Contaminant History.....	1-27
1.2.3 Nature and Extent of Contamination .....	1-35
1.2.4 Contaminant Fate and Transport.....	1-45
1.2.5 Previous Baseline Risk Assessment.....	1-49
2. IDENTIFICATION AND SCREENING OF TECHNOLOGIES .....	2-1
2.1 INTRODUCTION .....	2-1
2.2 REMEDIAL ACTION OBJECTIVES AND REMEDIATION GOALS.....	2-2
2.3 GENERAL RESPONSE ACTIONS.....	2-4
2.3.1 Interim LUCs .....	2-4
2.3.2 Monitoring .....	2-4
2.3.3 Monitored Natural Attenuation.....	2-4
2.3.4 Removal.....	2-4
2.3.5 Containment.....	2-7
2.3.6 Treatment.....	2-7
2.3.7 Disposal .....	2-7
2.4 IDENTIFICATION AND SCREENING OF TECHNOLOGY TYPES AND PROCESS OPTIONS.....	2-7
2.4.1 Identification and Screening of Technologies .....	2-7
2.4.2 Evaluation of Technologies and Selection of Representative Technologies .....	2-41
2.4.3 Representative Process Options.....	2-42
3. DEVELOPMENT AND SCREENING OF ALTERNATIVES .....	3-1
3.1 INTRODUCTION .....	3-1
3.2 CRITERIA FOR THE DEVELOPMENT OF REMEDIAL ALTERNATIVES .....	3-1
3.3 ARARS.....	3-1
3.4 DEVELOPMENT OF ALTERNATIVES.....	3-2
3.4.1 Alternative 1—No Further Action .....	3-2
3.4.2 Alternative 2—Long-Term Monitoring with Interim LUCs.....	3-2
3.4.3 Alternative 3— <i>In situ</i> Source Treatment Using Deep Soil Mixing with Interim LUCs.....	3-7
3.4.4 Alternative 4—Source Removal and <i>In situ</i> Chemical Source Treatment with Interim LUCs .....	3-14
3.4.5 Alternative 5— <i>In situ</i> Thermal Source Treatment with Interim LUCs .....	3-19
3.4.6 Alternative 6— <i>In situ</i> Source Treatment Using LAI with Interim LUCs.....	3-28
3.4.7 Alternative 7— <i>In situ</i> Soil Flushing and Source Treatment Using Multiphase Extraction with Interim LUCs .....	3-35

3.4.8 Alternative 8— <i>In situ</i> Source Treatment Using Enhanced <i>In situ</i> Bioremediation (EISB) with Interim LUCs .....	3-45
3.5 SCREENING OF ALTERNATIVES .....	3-52
4. DETAILED ANALYSIS OF ALTERNATIVES .....	4-1
4.1 INTRODUCTION .....	4-1
4.1.1 Purpose of the Detailed Analysis .....	4-1
4.1.2 Overview of the CERCLA Evaluation Criteria .....	4-1
4.1.3 Federal Facility Agreement and NEPA Requirements .....	4-37
4.2 MODELING RESULTS .....	4-40
4.3 DETAILED ANALYSIS OF ALTERNATIVES .....	4-42
4.3.1 Alternative 1—No Further Action .....	4-42
4.3.2 Alternative 2—Long-term Monitoring with Interim LUCs .....	4-43
4.3.3 Alternative 3— <i>In situ</i> Source Treatment Using Deep Soil Mixing with Interim LUCs....	4-45
4.3.4 Alternative 4—Source Removal and <i>In situ</i> Chemical Source Treatment with Interim LUCs .....	4-49
4.3.5 Alternative 5— <i>In situ</i> Thermal Source Treatment with Interim LUCs .....	4-53
4.3.6 Alternative 6— <i>In situ</i> Source Treatment Using LAI with Interim LUCs.....	4-56
4.3.7 Alternative 7— <i>In situ</i> Soil Flushing and Source Treatment Using Multiphase Extraction with Interim LUCs .....	4-59
4.3.8 Alternative 8— <i>In situ</i> Source Treatment Using EISB with Interim LUCs.....	4-64
5. COMPARATIVE ANALYSIS .....	5-1
5.1 THRESHOLD CRITERIA .....	5-1
5.1.1 Overall Protection of Human Health and the Environment .....	5-1
5.1.2 Compliance with ARARs .....	5-2
5.2 BALANCING CRITERIA.....	5-2
5.2.1 Long-Term Effectiveness and Permanence .....	5-2
5.2.2 Reduction of Toxicity, Mobility, and Volume through Treatment .....	5-3
5.2.3 Short-Term Effectiveness .....	5-4
5.2.4 Implementability .....	5-5
5.2.5 Cost .....	5-5
5.3 SUMMARY OF THE COMPARATIVE ANALYSIS OF ALTERNATIVES.....	5-5
6. REFERENCES .....	6-1
APPENDIX A: EVALUATION OF TECHNOLOGIES AND PROCESS OPTIONS.....	A-1
APPENDIX B: COST ESTIMATES .....	B-1
APPENDIX C: SOUTHWEST PLUME FOCUSED FEASIBILITY SESOIL AND AT123D AND DILUTION ATTENUATION FACTOR MODELING .....	C-1
APPENDIX D: BASELINE RISK ASSESSMENT FROM THE SOUTHWEST PLUME SI.....	D-1

## TABLES

ES.1.	Summary of Potential Source Areas and SWMU Numbers .....	ES-2
ES.2.	Summary of Investigations and Areas Investigated.....	ES-3
ES.3.	Summary of the Comparative Analysis of Alternatives* .....	ES-11
1.1.	Summary of Potential Source Areas and SWMU Numbers .....	1-6
1.2.	Summary of Investigations and Areas Investigated.....	1-36
1.3.	Basement Air Concentrations Based on Vapor Transport Modeling Results for FFS Source Areas .....	1-49
2.1.	Worker Protection RGs for VOCs at the C-720 Area and the Oil Landfarm Source Areas, mg/kg <sup>a</sup> .....	2-3
2.2.	Groundwater Protection RGs for VOCs at the C-720 Area and the Oil Landfarm Source Areas .....	2-3
2.3.	Results of Technology Identification and Screening.....	2-5
2.4.	Comparative Evaluation of Commercially Available Chemical Amendments .....	2-34
2.5.	Selection of Representative Process Options.....	2-43
3.1.	Alternative Formulation for the Oil Landfarm and the C-720 Northeast and Southeast Sites .....	3-3
3.2.	Initial Alternative Screening.....	3-52
3.3.	Summary of Screening of Alternatives.....	3-54
4.1.	Location-specific ARARs for the Oil Landfarm and the C-720 Northeast and Southeast Sites .....	4-3
4.2.	Action-specific ARARs for the Oil Landfarm and the C-720 Northeast and Southeast Sites.....	4-5
4.3.	Remedial Alternatives* and the Relative Impacts on Natural Resource .....	4-40
4.4.	Time to Attainment of MCLs for VOCs in the RGA from Oil Landfarm and C-720 Area Sources .....	4-41
4.5.	Summary of Estimated Costs for Alternative 2 .....	4-45
4.6.	Case Study Evaluation—Deep Soil Mixing.....	4-47
4.7.	Summary of Estimated Costs for Alternative 3 .....	4-49
4.8.	Summary of Estimated Costs for Alternative 4 .....	4-52
4.9.	Summary of Estimated Costs for Alternative 5 .....	4-55
4.10.	Case Study Evaluation—Jet-Assisted Injection.....	4-57
4.11.	Summary of Estimated Costs for Alternative 6 .....	4-60
4.12.	Case Study Evaluation—Multiphase Extraction.....	4-61
4.13.	Summary of Estimated Costs for Alternative 7 .....	4-64
4.14.	Case Study Evaluation—Bioremediation .....	4-65
4.15.	Summary of Estimated Costs for Alternative 8 .....	4-68
5.1.	Summary of Alternative Costs.....	5-6

**THIS PAGE INTENTIONALLY LEFT BLANK**

## FIGURES

1.1.	PGDP Site Location.....	1-3
1.2.	PGDP Land Ownership.....	1-4
1.3.	Trichloroethene Plume Locations.....	1-5
1.4.	Southwest Plume Potential Source Areas.....	1-7
1.5.	Anticipated Future Land Use.....	1-11
1.6.	Generalized Lithostratigraphic Column of the PGDP Region.....	1-16
1.7.	Water-Bearing Zones near the PGDP.....	1-18
1.8.	Hydrogeologic Cross Section A-A' at SWMU 1.....	1-21
1.9.	Geologic Cross Section B-B' at SWMU 1.....	1-22
1.10.	Geologic Cross Section A-A' at the C-720 Complex.....	1-23
1.11.	Geologic Cross Section B-B' at the C-720 Complex.....	1-24
1.12.	Geologic Cross Section C-C' at the C-720 Complex.....	1-25
1.13.	TCE Plume within the Study Area.....	1-28
1.14.	Geologic Cross Section B-B' at SWMU 1 with TCE Plume.....	1-29
1.15.	Geologic Cross Section C-C' at the C-720 Complex with TCE Plume.....	1-30
1.16.	Geologic Cross Section B-B' at the C-720 Complex with TCE Plume.....	1-31
1.17.	Conceptual Model for the SWMU 1 TCE Source Area.....	1-37
1.18.	Conceptual Model for the C-720 TCE Source Areas.....	1-38
1.19.	Exposure Pathway Conceptual Model for the Southwest Plume Source Areas.....	1-39
1.20.	TCE Results from SWMU 1 Sampling.....	1-40
1.21.	TCE Results from C-720 Building Area Sampling.....	1-44
3.1.	Schematic View of Alternative 2—Long-term Monitoring with Interim Land Use Controls at the Oil Landfarm Site.....	3-4
3.2.	Plan View of Alternative 2—Long-term Monitoring with Interim Land Use Controls at the Oil Landfarm Site.....	3-5
3.3.	Plan View of Alternative 2—Long-term Monitoring with Interim Land Use Controls at the C-720 Northeast and Southeast Sites.....	3-6
3.4.	Schematic View of Alternative 3— <i>In situ</i> Source Treatment Using Deep Soil Mixing with Interim Land Use Controls.....	3-9
3.5.	Plan View of Alternative 3— <i>In situ</i> Source Treatment Using Deep Soil Mixing with Interim Land Use Controls.....	3-11
3.6.	Schematic View of Alternative 4—Source Removal and <i>In situ</i> Chemical Source Treatment with Interim Land Use Controls.....	3-15
3.7.	Plan View of Alternative 4—Source Removal and <i>In situ</i> Chemical Source Treatment with Interim Land Use Controls.....	3-17
3.8.	Schematic View of Alternative 5— <i>In situ</i> Thermal Source Treatment with Interim Land Use Controls.....	3-21
3.9.	Plan View of Alternative 5 at the Oil Landfarm.....	3-23
3.10.	Plan View of Alternative 5 at C-720 Northeast and Southeast Sites.....	3-24
3.11.	Schematic View of Alternative 6— <i>In situ</i> Source Treatment Using Liquid Atomized Injection with Internal Land Use Controls.....	3-29
3.12.	Plan View of Alternative 6— <i>In situ</i> Source Treatment Using Liquid Atomized Injection with Interim Land Use Controls at the C-720 Northeast Site.....	3-31
3.13.	Plan View of Alternative 6— <i>In situ</i> Source Treatment Using Liquid Atomized Injection with Interim Land Use Controls at the C-720 Southeast Site.....	3-32
3.14.	Schematic View of Alternative 7— <i>In situ</i> Soil Flushing and Source Treatment Using Multiphase Extraction with Interim Land Use Controls.....	3-37

3.15.	Plan View of Alternative 7— <i>In situ</i> Soil Flushing and Source Treatment via Multiphase Extraction with Interim Land Use Controls at the C-720 Northeast Site .....	3-39
3.16.	Plan View of Alternative 7— <i>In situ</i> Soil Flushing and Source Treatment via Multiphase Extraction with Interim Land Use Controls at the C-720 Southeast Site .....	3-40
3.17.	Schematic View of Alternative 8— <i>In situ</i> Source Treatment Using EISB with Interim Land Use Controls.....	3-47
3.18.	Plan View of Alternative 8— <i>In situ</i> Source Treatment Using EISB with Interim Land Use Controls at the Oil Landfarm Site.....	3-49

## ACRONYMS

ALARA	as low as reasonably achievable
AOC	area of contamination
ARAR	applicable or relevant and appropriate requirement
ARD	anaerobic reductive dechlorination
AWQC	ambient water quality criteria
bgs	below ground surface
BHHRA	baseline human health risk assessment
BMP	best management practice
CERCLA	Comprehensive Environmental Response, Compensation, and Liability Act
<i>CFR</i>	<i>Code of Federal Regulations</i>
<i>cis-1,2-DCE</i>	<i>cis-1,2-dichloroethene</i>
COC	contaminant of concern
COE	U.S. Army Corps of Engineers
CRMP	Cultural Resources Management Plan
CSM	Conceptual Site Model
D&D	decontamination and decommissioning
DNAPL	dense nonaqueous-phase liquid
DOE	U.S. Department of Energy
DPT	direct-push technology
ECD	electron capture detector
EISB	enhanced <i>in situ</i> bioremediation
ELCR	excess lifetime cancer risk
E/PP	excavation/penetration permit
EPA	U.S. Environmental Protection Agency
ERH	electrical resistance heating
FFA	Federal Facility Agreement
FFS	focused feasibility study
<i>FR</i>	<i>Federal Register</i>
FY	fiscal year
GAC	granular-activated carbon
GC-MS	gas chromatography-mass spectrometry
GRA	general response action
HI	hazard index
HTTD	high temperature thermal desorption
HU	hydrogeologic unit
ISB-ARD	<i>in situ</i> bioremediation-anaerobic reductive dechlorination
ISCO	<i>in situ</i> chemical oxidation
ISRM	<i>in situ</i> redox manipulation
ITRD	Innovative Treatment and Remediation Demonstration
<i>KAR</i>	<i>Kentucky Administrative Rules</i>
KDEP	Kentucky Department for Environmental Protection
KOW	Kentucky Ordnance Works
KPDES	Kentucky Pollutant Discharge Elimination System
LAI	liquid atomized injection
LCD	Lower Continental Deposits
LDA	large diameter auger
LTTD	low temperature thermal desorption
LUC	land use control



MCL	maximum contaminant level
MDL	method detection limits
MIP	membrane interface probe
MMO	methane monooxygenase
MNA	monitored natural attenuation
MW	monitoring well
NAPL	nonaqueous-phase liquid
NCP	National Oil and Hazardous Substances Pollution Contingency Plan
NEPA	National Environmental Policy Act of 1969
NHPA	National Historic Preservation Act
NOAA	National Oceanic and Atmospheric Administration
NPL	National Priorities List
NRCS	Natural Resources Conservation Service
NV	no value
OH	hydroxyl free radicals
O&M	operation and maintenance
ORP	oxidation reduction potential
OU	operable unit
PCB	polychlorinated biphenyl
PCE	perchloroethene (tetrachloroethene)
PFM	passive fluxmeter
PGDP	Paducah Gaseous Diffusion Plant
PID	photoionization detector
PITT	Partitioning Interwell Tracer Test
POE	point of exposure
PPE	personal protective equipment
PRB	permeable reactive barrier
PTW	principal threat waste
PVC	polyvinyl chloride
RAO	remedial action objective
RAWP	remedial action work plan
RCRA	Resource Conservation and Recovery Act
RCW	recirculating cooling water
RD	remedial design
RDSI	remedial design site investigation
RG	remediation goal
RGA	Regional Gravel Aquifer
RI	remedial investigation
RNS	Ribbon NAPL Sampler
ROD	record of decision
RPO	representative process option
SERA	screening ecological risk assessment
SI	site investigation
SMP	Site Management Plan
SPH	six-phase heating
SVE	soil vapor extraction
SVOC	semivolatile organic compound
SWMU	solid waste management unit
Tc-99	technetium-99
TBC	to be considered
TCA	trichloroethane

TCE	trichloroethene
T&E	threatened and endangered
<i>trans</i> -1,2-DCE	<i>trans</i> -1,2-dichloroethene
TSCA	Toxic Substances Control Act
TVA	Tennessee Valley Authority
UCD	Upper Continental Deposits
UCRS	Upper Continental Recharge System
<i>USC</i>	<i>United States Code</i>
VC	vinyl chloride
VOC	volatile organic compound
WAG	waste area grouping
WKWMA	West Kentucky Wildlife Management Area
ZVI	zero-valent iron

**THIS PAGE INTENTIONALLY LEFT BLANK**

## EXECUTIVE SUMMARY

This *Revised Focused Feasibility Study for Solid Waste Management Units 1, 211A, and 211B Volatile Organic Compound Sources for the Southwest Groundwater Plume at the Paducah Gaseous Diffusion Plant, Paducah, Kentucky*, DOE/LX/07-0362&D1, (FFS) was prepared to develop and evaluate remedial alternatives for potential application at the U.S. Department of Energy's (DOE's) Paducah Gaseous Diffusion Plant (PGDP). This work was prepared in accordance with the requirements of the *Federal Facility Agreement for the Paducah Gaseous Diffusion Plant* (FFA) (EPA 1998a); the "Resolution of the Environmental Protection Agency Letter of Non-Concurrence for the Site Investigation Report for the Southwest Plume at the Paducah Gaseous Diffusion Plant, Paducah, Kentucky (DOE/OR/07-2180&D2/R1) and Notice of Informal Dispute Dated November 30, 2007, McCracken County, Kentucky, KY 8-890-008-982" (referred to as the Resolution) (EPA 2008a); and the *Memorandum of Agreement for Resolution of Informal Dispute for the Focused Feasibility Study for the Southwest Plume Volatile Organic Compound Sources Oil Landfarm and C-720 Northeast and Southeast Sites) at the Paducah Gaseous Diffusion Plant, Paducah, KY* (EPA 2010). This FFS has been developed as a revision to the *Focused Feasibility Study for the Southwest Groundwater Plume Volatile Organic Compound Sources (Oil Landfarm and C-720 Northeast and Southeast Sites) at the Paducah Gaseous Diffusion Plant, Paducah, Kentucky* (DOE 2010a). In addition to the U.S. Environmental Protection Agency (EPA) requirements, National Environmental Policy Act of 1969 (NEPA) values, consistent with the DOE's Secretarial Policy Statement on NEPA in June 1994 (DOE 1994), are evaluated and documented in this FS. This FFS will be provided to trustee agencies for their review. It is DOE's policy to integrate natural resource concerns early into the investigation and remedy selection process to minimize unnecessary resource injury.

The Southwest Groundwater Plume refers to an area of groundwater contamination at PGDP in the Regional Gravel Aquifer (RGA), which is south of the Northwest Groundwater Plume and west of the C-400 Building. The plume was identified during the Waste Area Grouping (WAG) 27 Remedial Investigation (RI) in 1998. Additional work to characterize the plume [Solid Waste Management Unit (SWMU) 210] was performed as part of the WAG 3 RI and Data Gaps Investigations, both in 1999. As discussed in these reports, the primary groundwater contaminant of concern (COC) for the Southwest Groundwater Plume (hereinafter referred to as the Southwest Plume) is trichloroethene (TCE). Other contaminants found in the plume include additional volatile organic compounds (VOCs), metals, and the radionuclide, technetium-99. The PGDP is posted government property and trespassing is prohibited. Access to PGDP is controlled by guarded checkpoints, a perimeter fence, and vehicle barriers and is subject to routine patrol and visual inspection by plant protective forces.

DOE conducted a Site Investigation (SI) in 2004 to address the uncertainties with potential source areas to the Southwest Plume that remained after previous investigations. The SI further profiled the current level and distribution of VOCs in the dissolved-phase plume along the west plant boundary. Results of the SI were reported in the *Site Investigation Report for the Southwest Groundwater Plume at the Paducah Gaseous Diffusion Plant, Paducah, Kentucky*, DOE/OR/07-2180&D2/R1 (DOE 2007). This FFS is based on the SI as well as previous investigations identified below.

The potential source areas investigated in the SI (DOE 2007) included the C-747-C Oil Landfarm (Oil Landfarm); C-720 Building Area near the northeast and southeast corners of the building (C-720 Northeast Site and C-720 Southeast Site); and the storm sewer system between the south side of the C-400 Building and Outfall 008 (Storm Sewer). As a result of the Southwest Plume SI, the storm sewer subsequently was excluded as a potential VOC source to the Southwest Plume. Respective SWMU numbers for each potential source area investigated in the SI are provided in Table ES.1.

**Table ES.1. Summary of Potential Source Areas and SWMU Numbers**

<b>Description</b>	<b>SWMU No.</b>
C-747-C Oil Landfarm	1
Plant Storm Sewer	Part of 102
C-720 TCE Spill Sites Northeast and Southeast	211 A&B

In November 2007, the EPA invoked an informal dispute on the Southwest Plume SI. In March 2008, DOE signed the Resolution which required, among other things, that DOE conduct an FFS for addressing source areas to the Southwest Plume, in view of developing remedial alternatives and undertaking a Comprehensive Environmental Response, Compensation, and Liability Act (CERCLA) (42 *USC* 9601 *et seq.* 1980) remedial action and Record of Decision (ROD). The source areas subject to the FFS included the Oil Landfarm, C-720 Northeast and Southeast Sites, and Storm Sewer. The FFS was to address contamination in the shallow groundwater and could be based upon the Southwest Plume SI data, previous documents, and additional information, as necessary. The FFS was required to contain, among other information, a remedial action objective (RAO) for addressing source areas, including treatment and/or removal of principal threat waste (PTW) consistent with CERCLA, the National Oil and Hazardous Substances Pollution Contingency Plan (NCP) (including the preamble) and pertinent EPA guidance. The Southwest dissolved-phase plume in the Groundwater Operable Unit (OU) Dissolved-Phase Plumes would include the RAO of returning contaminated groundwater to beneficial use(s) and attaining chemical-specific applicable or relevant and appropriate requirements (ARARs), and/or attaining risk-based concentrations for all identified COCs throughout the plume (or at the edge of the waste management area depending on whether the waste source was removed), consistent with CERCLA, the NCP (including the preamble), and pertinent EPA guidance.

In April 2010, DOE invoked an informal dispute on the *Focused Feasibility Study for the Southwest Groundwater Plume Volatile Organic Compound Sources (Oil Landfarm and C-720 Northeast and Southeast Sites) at the Paducah Gaseous Diffusion Plant, Paducah, Kentucky* (DOE 2010a). In May 2010, EPA, DOE, and the Kentucky Department for Environmental Protection entered into an agreement resolving the dispute.

EPA typically describes sources as material that includes hazardous substances, pollutants, or contaminants that act as a reservoir for the groundwater, surface water, or air or act as a source of direct exposure. EPA considers sources or source materials to be principal threats when they are highly toxic or highly mobile and generally cannot be reliably contained or would present a significant risk to human health or the environment should exposure occur (EPA 2004a). Previous investigations of FFS source areas to a depth of 55 ft below ground surface (bgs) identified the potential presence of TCE dense nonaqueous-phase liquid (DNAPL), which would constitute PTW.

### **SCOPE OF THE SOUTHWEST PLUME FFS IN THE SITEWIDE GROUNDWATER OU**

This FFS will support a final action to mitigate the migration of VOCs from the Oil Landfarm and the C-720 Building Area to the Southwest Plume and to treat or remove PTW. Based on results from the Southwest Plume SI, the Storm Sewer no longer is considered a source of VOC contamination to the Southwest Plume. Risks posed by direct contact with contaminated surface soil or sediment at the Oil Landfarm and C-720 Building Area or remaining risks from potential use of contaminated groundwater from VOC and non-VOC contaminants will be addressed later as part of the decisions for the Surface Water, Soils, or Groundwater OUs.

These VOC source areas are assigned to the Groundwater OU at PGDP, which is one of five media-specific sitewide OUs being used to evaluate and implement remedial actions. Consistent with EPA guidance (EPA 2004a), the Groundwater OU is being implemented in a phased approach consisting of sequenced remedial and removal actions designed to accomplish the following goals:

- (1) Prevent human exposure to contaminated groundwater;
- (2) Prevent or minimize further migration of contaminant plumes;
- (3) Prevent, reduce, or control contaminant sources contributing to groundwater contamination; and
- (4) Restore the groundwater to its beneficial uses, wherever practicable.

This FFS and ensuing final VOC remedial action will support the phased groundwater goals represented in goals 3 and 4 above by controlling VOC migration (including DNAPL) that contribute to groundwater contamination, thereby promoting the restoration of groundwater to beneficial use, as practicable. The remedial action also is anticipated to substantially reduce the risk and hazard from hypothetical groundwater use associated with releases from these source areas.

Evaluation of a final remedial action for additional COCs (non-VOCs) associated with direct contact exposure risks will be addressed by the Soils Operable Unit, as described in the 2010 Site Management Plan. Groundwater contamination will be addressed through the Dissolved-Phase Plumes Remedial Action.

## PREVIOUS INVESTIGATIONS

This FFS is based on findings from the multiple investigations summarized in Table ES.2.

**Table ES.2. Summary of Investigations and Areas Investigated**

<b>Date</b>	<b>Title</b>	<b>Southwest Plume</b>	<b>Oil Landfarm</b>	<b>C-720 Building Area</b>	<b>Storm Sewer</b>	<b>SWMU 4*</b>
1989–1990	Phase I SI		✓		✓	✓
1990–1991	Phase II SI		✓	✓	✓	✓
1996	Site-specific sampling		✓			
1997	WAG 6 Remedial Investigation				✓	
1998	WAG 23 Removal Action		✓			
1998	WAG 27 Remedial Investigation	✓	✓	✓		
1999	Sitewide Data Gaps Investigation	✓				
1999	WAG 3 Remedial Investigation	✓				✓
2001	Groundwater OU Feasibility Study	✓	✓	✓	✓	
2007	Southwest Plume Site Investigation	✓	✓	✓	✓	✓

\*SWMU 4 is a component of the Burial Ground Operable Unit and will be remediated as necessary under that operable unit.

## SOURCE AREAS AND NATURE AND EXTENT OF CONTAMINATION

### C-747-C Oil Landfarm (SWMU 1)

Between 1973 and 1979 the Oil Landfarm was used for landfarming waste oils contaminated with TCE, uranium, polychlorinated biphenyls (PCBs), and 1,1,1-trichloroethane (TCA). These waste oils are believed to have been derived from a variety of PGDP processes. The landfarm consisted of two 104.5-m<sup>2</sup> (1,125- ft<sup>2</sup>) plots that were plowed to a depth of 0.305 to 0.61 m (1 to 2 ft). Waste oils were spread on the surface every 3 to 4 months; then the area was limed and fertilized.

Investigations of the Oil Landfarm include the Phase I and Phase II SI (CH2M HILL 1991; CH2M HILL 1992), additional sampling performed to support the *Feasibility Study for the Waste Area Group 23 and Solid Waste Management Unit 1 of Waste Area Group 27 at the Paducah Gaseous Diffusion Plant, Paducah, Kentucky* (DOE 1996a) and resulting Removal Action (DOE 1998a), and the *Remedial Investigation Report for Waste Area Grouping 27 at the Paducah Gaseous Diffusion Plant, Paducah, Kentucky* (DOE 1999a). These investigations and actions identified VOCs, PCBs, dioxins, semivolatile organic compounds, heavy metals, and radionuclides as COCs. As part of the Waste Area Group (WAG) 23 Removal Action, 17.58 m<sup>3</sup> (23 yd<sup>3</sup>) of dioxin-contaminated soil was excavated and removed from the unit. Samples collected in a WAG 23 focused sampling event in February of 1996 from SWMU 1 indicated the presence of *cis*-1,2-dichloroethene (*cis*-1,2-DCE) concentrations as high as 2,400 milligrams per kilogram (mg/kg). Results of the WAG 23 focused sampling were published in the WAG 23 FS (DOE 1996a). During the WAG 27 RI, the maximum detected TCE concentration was 439 mg/kg at 4.6 m (15 ft) bgs with most TCE concentrations less than 100 mg/kg.

During the Southwest Plume SI, five soil borings were placed within and adjacent to the contaminated area defined in the WAG 27 RI. No RGA groundwater samples were collected at this unit. The highest levels of total VOCs detected in a single sample collected during the SI sampling event included TCE (3.5 mg/kg) and degradation products *cis*-1,2-DCE (1.5 mg/kg) and vinyl chloride (VC) (0.02 mg/kg), TCA (0.05 mg/kg), and 1,1-DCE (0.07 mg/kg). Some or all of these products were detected in samples from all sample intervals at the location collected down to a total depth of 18.1 m (59.5 ft). The high TCE concentration (3.5 mg/kg) was detected at 14.3 m (47 ft) bgs. Significant levels of TCE (1.8 mg/kg) and *cis*-1,2-DCE (0.086 mg/kg) were detected in a second location from all intervals collected to a depth of 17.07 m (56 ft), with the highest level of TCE detected at 17.07 m (56 ft) bgs. A third location exhibited lower levels of TCE and its degradation products, with the highest level of TCE (0.98 mg/kg) detected at 9.1 m (30 ft) bgs together with TCA (0.0034 mg/kg). Low levels of TCE (0.37 mg/kg) and *cis*-1,2-DCE (0.2 mg/kg) were detected at 13.8 m (45.5 ft) in a fourth sample location. The fifth location did not contain any detectable concentrations of TCE or its degradation products, but had a slight detection of carbon disulfide (0.014 mg/kg) at 10.1 m (33 ft), which was the only contaminant present at concentrations above the method detection limit (MDL).

### C-720 Building Area

The WAG 27 RI identified areas of TCE contamination at the C-720 Building Area. This FFS addresses two areas that were identified in the Resolution. One area was underneath the parking lot and equipment storage area at the northeast corner of the building. The second area was located underneath the parking lot adjacent to the loading docks at the southeast corner of the building.

**C-720 Northeast Site (SWMU 211A).** Contamination found to the northeast of the C-720 Building is believed to have been released during routine equipment cleaning and rinsing performed in the area. Solvents were used to clean parts, and the excess solvent may have been discharged on the ground. Spills and leaks from the cleaning process also may have contaminated surface soils in the area. Solvents may

have migrated as dissolved contamination, leached by rainfall or facility water percolating through the soils and migrating to deeper soils and the shallow groundwater, or as DNAPL, migrating to adjacent and underlying soils. Soils and groundwater containing TCE will be considered a Resource Conservation and Recovery Act listed hazardous waste until the materials can be further characterized. In the WAG 27 RI, the maximum TCE concentration detected (8.1 mg/kg) was in a sample located immediately north of the parking lot at 9.1 m (30 ft) bgs.

During the Southwest Plume SI, six borings were placed between the north edge of the parking lot and a storm sewer to which all surface runoff for the parking lot flows. Results indicated that soils containing very low levels of VOC contamination were detectable in the subsurface of the northeast corner of the C-720 Building Area. The highest level of TCE (0.98 mg/kg) detected during the SI sampling event was at 15.1 m (49.5 ft) bgs, with low levels of *cis*-1,2-DCE (0.05 mg/kg) and 1,1-DCE (0.02 mg/kg) detected. Carbon disulfide (0.005 mg/kg) was detected at this location as well, but not detected at any other location during investigation of the northeast corner source area. The second highest sample identified a maximum TCE concentration of 0.63 mg/kg at 17.2 m (56.5 ft), with no degradation products detected above the MDLs. A third location had a similar maximum detected TCE level of 0.6 mg/kg at 14 m (46 ft) and included *cis*-1,2-DCE (0.019 mg/kg). The remaining three locations had low levels of TCE (0.01 to 0.06 mg/kg) and degradation products and other VOCs including tetrachloroethene, 1,2-dichloroethane, 1,1-DCE, carbon tetrachloride, and chloroform detected. The results confirmed that contamination had migrated to the area's deeper soil.

Samples from a well cluster completed in the Upper Continental Recharge System (UCRS) and the RGA were the only groundwater samples collected during the investigation of this unit. The TCE levels declined from the UCRS to the RGA wells (280 to 99 µg/L).

**C-720 Southeast Site (SWMU 211B).** The source of VOC contamination found southeast of the C-720 Building is not certain. The VOCs found in this area may have originated from spills that occurred within the building, with subsequent discharge to storm drains leading to the southeast corner of the building or from spills or leaks on the loading dock or parking lot located to the southeast of the building. The area of concern discovered during the WAG 27 RI is near the outlet to one of the storm drains for the east end of the building. A storm sewer inlet for the southeast parking lot also is located in the vicinity. The north edge of the parking lot, where the contamination occurs, is the location of one of the loading docks for the C-720 Building, an area where chemicals, including solvents, may have been loaded or unloaded. In the WAG 27 RI, the maximum TCE concentration detected was 68 mg/kg at 6.4 m (21 ft) bgs.

During the Southwest Plume SI, two borings were placed through the parking lot adjacent to the C-720 Building loading dock. No groundwater samples were collected during investigation of this unit. Samples had low levels of TCE [maximum 0.20 mg/kg at 8.84 m (29 ft) bgs] with no associated degradation products. The results indicated that the locations sampled were at the periphery of the source area defined in the WAG 27 RI.

#### **Plant Storm Sewer (SWMU 102)**

During the WAG 6 RI (DOE 1999b), VOC contamination of subsurface soils was identified near two of the lateral lines that feed into the main storm sewer that runs south of the C-400 Building to Outfall 008 on the west side of PGDP. At one time, the eastern lateral appears to have been connected to the TCE degreaser sump inside the C-400 Building. The TCE that leaked from the sump/storm sewer connection to the surrounding soils had been identified as a potential source of groundwater contamination. There was a possibility that TCE was transported down the lateral to the main storm sewer line running to Outfall 008, encountered an undetermined breach in the storm sewer, and leaked to the surrounding soils to become a source of TCE to the Southwest Plume.



Soil sample results from the Southwest Plume SI indicated that low levels of VOCs were present in the backfill at the Storm Sewer (DOE 2007). No groundwater samples were taken during the investigation of this unit. A video survey that confirmed the integrity of the Storm Sewer, combined with the soil sampling results, demonstrated that the Storm Sewer was not a source of contamination to the Southwest Plume; therefore, the Storm Sewer was not carried forward in the FFS for alternative evaluation.

## **PREVIOUS BASELINE RISK ASSESSMENT**

The Southwest Plume SI (DOE 2007) used historical information and newly collected data to develop a site model for each source area and presented a baseline human health risk assessment (BHHRA) and a screening ecological risk assessment (SERA). In the BHHRA, information collected during the Southwest Plume SI and results from previous risk assessments were used to characterize the baseline risks posed to human health and the environment resulting from contact with contaminants in groundwater drawn from the Southwest Plume in the RGA at the source areas. In addition, fate and transport modeling of selected VOCs (TCE, *cis*-1,2-DCE, *trans*-1,2-DCE, and VC) in subsurface soils to RGA groundwater was conducted. These results were used to estimate the future baseline risks that might be posed to human health and the environment through contact with groundwater impacted by contaminants migrating from the Oil Landfarm and C-720 Building Area to four points of exposure (POEs). The POEs assessed were at the source, the plant boundary, DOE property boundary, and near the Ohio River. The modeling was initiated after it was observed that cleanup levels determined to be protective of a rural resident using groundwater drawn from a well at a PGDP property boundary were similar to or less than the average concentrations of TCE in the Oil Landfarm and C-720 Building Area sources (DOE 2007). EPA disagreed with the use of multiple POEs (especially the Plant and Facility boundaries) for purposes of determining unacceptable risk to hypothetical residential users due to contaminated groundwater and that widespread exceedances of maximum contaminant levels (MCLs) and/or risk-based concentrations in the groundwater warranted a response action for the Southwest Plume.

Inhalation of vapor released from the groundwater into home basements was modeled quantitatively for hypothetical rural residents based on measured TCE, *cis*-1,2-DCE, *trans*-1,2-DCE, and VC concentration at the Oil Landfarm and the C-720 Building Area, as well as modeled TCE concentrations at the plant and property boundaries. The potential air concentrations also were used for estimating excess lifetime cancer risk (ELCR) and hazard for the hypothetical future on- and off-site rural resident.

Because data collected during the SI focused on the collection of subsurface soil and groundwater data to delimit the potential sources of contamination to the Southwest Plume, the new material developed in the BHHRA and SERA was limited to risks posed by contaminants migrating from potential source areas to RGA groundwater and with direct contact with contaminated groundwater in the source areas.

## **BASELINE RISK ASSESSMENT CONCLUSIONS**

For both the Oil Landfarm and the C-720 Building Area, the cumulative human health ELCR and hazard index (HI) exceeded *de minimis* levels [i.e., a cumulative ELCR of  $1 \times 10^{-6}$  or a cumulative HI of 1] in the PGDP Risk Methods Document for one or more scenarios (DOE 2001a). Additionally, risks from household use of groundwater by a hypothetical on-site rural resident also exceeded those standards. The land uses and media assessed for ELCR and HI to human health for each potential source area were taken from earlier assessments with the exception of groundwater use and vapor intrusion by the hypothetical future on- and off-site rural resident. These were newly derived in the BHHRA from measured and modeled data collected during the Southwest Plume SI and previous investigations.

In the BHHRA, it was determined that the hypothetical rural residential use of groundwater scenario and vapor intrusion is of concern for both ELCR and HI at each source area, except the Storm Sewer, which is of concern for ELCR only. The exposure routes of ingestion of groundwater, inhalation of gases emitted while using groundwater in the home, and vapor intrusion from the groundwater into basements account for about 90% of the total ELCR and HI.

For groundwater use by the hypothetical adult resident at the Oil Landfarm, VOC COCs include TCE; *cis*-1,2-DCE; chloroform; and 1,1-DCE; all of which are “Priority COCs” (i.e., chemical-specific HI or ELCR greater than or equal to 1 or  $1 \times 10^{-4}$ , respectively), except for 1,1-DCE. The VOCs make up 78% of a cumulative ELCR of  $6.8 \times 10^{-4}$  and 76% of a cumulative HI of 26. For groundwater use by the hypothetical child resident, VOC COCs include TCE; *cis*-1,2-DCE, and chloroform, all of which are “Priority COCs.” These VOCs make up 85% of a cumulative HI of 99.

At the C-720 Building Area, the VOC COCs for groundwater use by the hypothetical adult resident include TCE; *cis*-1,2-DCE; VC; and 1,1-DCE, with all except VC being “Priority COCs.” The VOCs make up 93% of a cumulative ELCR of  $1.8 \times 10^{-3}$  and 57% of the cumulative HI of 23. For groundwater use by the hypothetical child resident, VOC COCs include TCE; *cis*-1,2-DCE; *trans*-1,2-DCE; and 1,1-DCE, all of which are “Priority COCs,” except for *trans*-1,2-DCE. The VOCs make up 76% of a cumulative HI of 102.

At the Storm Sewer, the hypothetical adult residential COCs include TCE and 1,1-DCE, neither of which is a “Priority COC.” The VOCs make up 100% of a cumulative ELCR of  $7.9 \times 10^{-6}$ . The HI for the storm sewer was less than 1 and, therefore, not of concern. For groundwater use by the hypothetical child resident at the Storm Sewer, COCs include TCE and 1,1-DCE, neither of which is a “Priority COC.” The VOCs make up 100% of a cumulative HI of 0.6 for the child hypothetical resident.

At the property boundary for the hypothetical adult resident, the migrating COCs from the Oil Landfarm are TCE and VC with no “Priority COCs.” The VOCs make up 100% of the total ELCR of  $1.4 \times 10^{-6}$  and the HI is less than 0.1. For the hypothetical child resident at the property boundary the COCs are TCE and *cis*-1,2-DCE with no “Priority COCs.” The VOCs make up 85% of a cumulative HI of 0.4 for the child hypothetical resident.

The COC migrating from the C-720 Building Area to the hypothetical adult resident at the property boundary is VC, which is not a “Priority COC.” The VC makes up greater than 95% of the total ELCR of  $1.1 \times 10^{-6}$  and the HI is less than 0.1. For the hypothetical child resident at the property boundary, the HI is less than 1. Based on results of previous and current modeling reported in the SI BHHRA, neither metals nor radionuclides are COCs for contaminant migration from the Oil Landfarm or C-720 Building Area.

The SERA, which used results taken from the Baseline Ecological Risk Assessment completed as part of the WAG 27 RI, concluded that a lack of suitable habitat in the industrial setting at the Oil Landfarm and the C-720 Building Area precluded exposures of ecological receptors under current conditions; therefore, it was determined during problem formulation that an assessment of potential risks under current conditions was unnecessary.

## **REMEDIAL ACTION OBJECTIVES**

The Resolution (EPA 2008a) required that the FFS include an RAO for addressing source areas, including treatment and/or removal of PTW consistent with CERCLA, the NCP (including the preamble), and pertinent EPA guidance. RAOs were developed collaboratively with the EPA and Kentucky and are

focused on VOCs in soils. The resulting RAOs were used in screening technologies and developing and evaluating alternatives for the Oil Landfarm and C-720 Northeast and Southeast Sites:

- (1) Treat and/or remove PTW consistent with the NCP.
- (2a) Prevent exposure to VOC contamination in the source areas that will cause an unacceptable risk to excavation workers (<10 ft).
- (2b) Prevent exposure to non-VOC contamination and residual VOC contamination through interim land use controls (LUCs) within the Southwest Plume source areas (i.e., SWMU 1, SWMU 211-A and SWMU 211-B), pending remedy selection as part of the Soils OU and the Groundwater OU.
- (3) Reduce VOC migration from contaminated subsurface soils in the treatment areas at the Oil Landfarm and C-720 Northeast and Southeast Sites so that contaminants migrating from the treatment areas do not result in the exceedance of MCLs in the underlying groundwater.

Two types of RGs were developed to support the RAOs. Worker protection remediation goals (RGs) are VOC concentrations in soils present at depths of 0-10 ft that would meet RAO #2a with no other controls necessary. Groundwater protection RGs are VOC concentrations in subsurface soils that would meet RAO #3 with no other controls necessary.

For purposes of the FFS, the treatment zone encompasses the soils directly below and within the boundaries of the Oil Landfarm and C-720 Northeast and Southeast Sites. Soil RGs calculated for the purposes of this document are based on VOC contaminant concentrations in soil that would not result in exceedance of the MCLs in the RGA groundwater.

Alternatives were evaluated with respect to their effectiveness at attaining RGs and meeting the RAOs based on previous source removal demonstrations at PGDP; literature reports of previous actions at other sites; modeling of VOCs to determine exceedances of MCLs; and engineering judgment. After final remedy selection, further definition for completion criteria will be stated in the ROD and quantified as appropriate in the Remedial Action Work Plan.

## **APPLICABLE OR RELEVANT AND APPROPRIATE REQUIREMENTS**

CERCLA Section 121(d) and the NCP require compliance with ARARs as one of the threshold criteria. Also, per the NCP at 40 *CFR* § 300.430(e)(9)(iii)(B), remedial alternatives shall be assessed to determine whether they attain ARARs under federal environmental laws and state environmental or facility siting laws or provide grounds for invoking a CERCLA waiver. ARARs do not include occupational safety or worker protection requirements. Additionally, per 40 *CFR* § 300.405(g)(3), other advisories, criteria, or guidance may be considered in determining remedies [to be considered (TBC) category]. The CERCLA 121(d)(4) provides several ARAR waiver options that may be invoked, provided that human health and the environment are protected.

ARARs typically are divided into three categories: (1) chemical-specific, (2) location-specific, and (3) action-specific. Chemical-specific ARARs provide health- or risk-based concentration limits or discharge limitations in various environmental media (i.e., surface water, groundwater, soil, or air) for specific hazardous substances, pollutants, or contaminants. Location-specific ARARs establish restrictions on permissible concentrations of hazardous substances or establish requirements for how activities will be conducted because they are in special locations (e.g., floodplains or historic districts).

Action-specific ARARs include operation, performance, and design of the preferred alternative based on waste types and/or media to be addressed and removal/remedial activities to be implemented.

There are no chemical-specific ARARs for remediation of the contaminated subsurface soils at the source areas; however, Kentucky drinking water standard MCLs at 401 KAR 8:420 for VOCs were used for calculation of soil RGs. Location- and action-specific ARARs have been identified and evaluated for each alternative in Section 4.

## ALTERNATIVES

A primary objective of the FFS is to identify remedial technologies and process options that potentially meet the RAOs and then combine them into a range of remedial alternatives. CERCLA requires development and evaluation of a range of responses, including a no-action alternative, to ensure that an appropriate remedy is selected. The selected final remedy must comply with ARARs and must protect human health and the environment. The technology screening process consists of a series of steps that include the following:

- Identifying general response actions (GRAs) that may meet RAOs, either individually or in combination with other GRAs;
- Identifying, screening, and evaluating remedial technology types for each GRA; and
- Selecting one or more representative process options (RPOs) for each technology type.

DOE identified GRAs potentially applicable to the Southwest Plume source areas. These GRAs include LUCs, monitoring, monitored natural attenuation, containment, removal, treatment, and disposal. Technology types and process options representative of the GRAs then were identified, screened, and evaluated. The criteria for identifying, screening, and evaluating technologies are provided in EPA's *Guidance for Conducting Remedial Investigations and Feasibility Studies Under CERCLA* (EPA 1988) and the NCP. The initial technology screening eliminated some technologies on the basis of technical impracticability.

Following the technology screening, RPOs were identified for each technology type. RPOs were selected on the basis of effectiveness, technical and administrative implementability, and cost, relative to other technologies in the same technology type. Alternatives then were developed by combining RPOs into a range of comprehensive strategies to meet the RAOs.

The following alternatives were developed:

- Alternative 1: No further action
- Alternative 2: Long-term monitoring with interim LUCs
- Alternative 3: *In situ* source treatment using deep soil mixing with interim LUCs
- Alternative 4: Source removal and *in situ* chemical source treatment with interim LUCs
- Alternative 5: *In situ* Thermal Treatment and interim LUCs
- Alternative 6: *In situ* source treatment using liquid atomized injection with interim LUCs
- Alternative 7: *In situ* soil flushing and source treatment via multiphase extraction with interim LUCs
- Alternative 8: *In situ* source treatment using enhanced *in situ* bioremediation with interim LUCs

Alternatives 6 and 7 were screened out of further evaluation at the Oil Landfarm due to the high relative cost and difficulty in implementation due to the lower permeability soils. Alternatives 3 and 4 were screened out of further evaluation at the C-720 Northeast and Southeast Sites on the basis of low technical implementability, respectively, in comparison to other alternatives. Alternative 8 relies heavily on the introduction of a bioamendment through the use of a horizontal infiltration gallery at the original location of VOC contamination release into the subsurface. The original VOC migration pathways are well known in the case of the Oil Landfarm, but not necessarily at the C-720 sites. In addition, due to the presence of subsurface utilities and concrete surface cover, horizontal infiltration galleries are not considered technically implementable at the C-720 Sites. For these reasons, Alternative 8 was screened out of further evaluation at the C-720 Northeast and Southeast Sites. Alternatives 1, 2, 3, 4, 5, and 8 were advanced to detailed analysis at the Oil Landfarm. Alternatives 1, 2, 5, 6, and 7 were advanced to detailed analysis at the C-720 Northeast and Southeast Sites.

Alternatives are analyzed in detail and compared based on the CERCLA evaluation criteria. Overall protection of human health and the environment and compliance with ARARs are categorized as threshold criteria that any viable alternative must meet. Long-term effectiveness and permanence; reduction of toxicity, mobility, and volume through treatment; short-term effectiveness; implementability; and cost are considered balancing criteria upon which the detailed analysis is primarily based. Modifying criteria (i.e., state and community acceptance) are evaluated following comment on the FFS and the Proposed Plan and are addressed as a final decision is made and the ROD is prepared.

The comparative analysis identifies the relative advantages and disadvantages of each alternative, so that the key tradeoffs that risk managers must balance can be identified. Alternatives are ranked with respect to the evaluation criteria, and the overall detailed and comparative evaluations are summarized. Results of the detailed and comparative analysis form the basis for preparing the Proposed Plan. Table ES.3 summarizes the results of the comparative analysis where a ranking of 1 least meets the criteria, and 9 best meets the criteria.

**Table ES.3. Summary of the Comparative Analysis of Alternatives\***

<b>Preliminary Ranking of Alternatives for the Oil Landfarm Site</b>								
	<b>Alternative 1</b>	<b>Alternative 2</b>	<b>Alternative 3</b>	<b>Alternative 4</b>	<b>Alternative 5</b>	<b>Alternative 6</b>	<b>Alternative 7</b>	<b>Alternative 8</b>
<b>Evaluation Criteria</b>	No Further Action	Long-term Monitoring	<i>In situ</i> Source Treatment Using Deep Soil Mixing	Source Removal and <i>In situ</i> Chemical Source Treatment	<i>In situ</i> Thermal Source Treatment	<i>In situ</i> Source Treatment Using LAI	<i>In situ</i> Soil Flushing and Source Treatment Using Multiphase Extraction	<i>In situ</i> Source Treatment Using EISB
Overall Protection of Human Health and the Environment	Does not meet the threshold criterion	Meets the threshold criterion	Meets the threshold criterion	Meets the threshold criterion	Meets the threshold criterion	NA	NA	Meets the threshold criterion
Compliance with ARARs	Does not meet the threshold criterion	Meets the threshold criterion	Meets the threshold criterion	Meets the threshold criterion	Meets the threshold criterion	NA	NA	Meets the threshold criterion
Long-term effectiveness	Low (1)	Moderate to Low (3)	Moderate to High (7)	Moderate to High (7)	Moderate to High (7)	NA	NA	Moderate (5)
Reduction in toxicity, mobility, or volume through treatment	Low (1)	Low (1)	Moderate to High (7)	High (9)	High (9)	NA	NA	Moderate to High (7)
Short-term effectiveness	Low (1)	Moderate to Low (3)	Moderate to High (7)	Moderate (5)	Moderate (5)	NA	NA	Moderate to Low (3)
Implementability	High (9)	High (9)	Moderate (5)	Moderate to Low (3)	Moderate to Low (3)	NA	NA	Moderate to High (7)
Overall cost rating**	High (9)	High (9)	Moderate to Low (3)	Low (1)	Low (1)	NA	NA	High (9)
Average Balancing Criteria Rating	<b>4.2</b>	<b>5</b>	<b>5.8</b>	<b>5</b>	<b>5</b>	NA	NA	<b>6.2</b>
Total Project Cost (Escalated)	\$0	\$2.2M	\$9.7M	\$12.1M	\$17.2M	NA	NA	\$6.1M
Total Project Cost (Unescalated)	\$0	\$2.1M	\$9.5M	\$11.8M	\$16.7M	NA	NA	\$5.9M
Total Project Cost (Present Worth)	\$0	\$1.7M	\$9.1M	\$11.4M	\$16.3M	NA	NA	\$5.5M

Table ES.3. Summary of the Comparative Analysis of Alternatives\* (Continued)

Preliminary Ranking of Alternatives for the C-720 Northeast Site								
	Alternative 1	Alternative 2	Alternative 3	Alternative 4	Alternative 5	Alternative 6	Alternative 7	Alternative 8
<b>Evaluation Criteria</b>	No Further Action	Long-term Monitoring	<i>In situ</i> Chemical Source Treatment Using Deep Soil Mixing	Source Removal and <i>In situ</i> Chemical Source Treatment	<i>In situ</i> Thermal Source Treatment	<i>In situ</i> Source Treatment Using LAI	<i>In situ</i> Soil Flushing and Source Treatment Using Multiphase Extraction	<i>In situ</i> Source Treatment Using EISB
Overall Protection of Human Health and the Environment	Does not meet the threshold criterion	Meets the threshold criterion	NA	NA	Meets the threshold criterion	Meets the threshold criterion	Meets the threshold criterion	NA
Compliance with ARARs	Does not meet the threshold criterion	Meets the threshold criterion	NA	NA	Meets the threshold criterion	Meets the threshold criterion	Meets the threshold criterion	NA
Long-term effectiveness	Low (1)	Moderate to Low (3)	NA	NA	Moderate to High (7)	Moderate (5)	Moderate to High (7)	NA
Reduction in toxicity, mobility, or volume through treatment	Low (1)	Low (1)	NA	NA	High (9)	Moderate to High (7)	High (9)	NA
Short-term effectiveness	Low (1)	Moderate to Low (3)	NA	NA	Moderate to High (7)	Moderate (5)	Moderate to High (7)	NA
Implementability	High (9)	High (9)	NA	NA	Low (1)	Moderate (5)	Moderate to Low (3)	NA
Overall cost rating**	High (9)	High (9)	NA	NA	Low (1)	Moderate to Low (3)	Moderate to Low (3)	NA
Average Balancing Criteria Rating	<b>4.2</b>	<b>5</b>	NA	NA	<b>5</b>	<b>5</b>	<b>5.8</b>	NA
Total Project Cost (Escalated)	\$0	\$2.2M	NA	NA	\$7.1M	\$3.8M	\$4.4M	NA
Total Project Cost (Unescalated)	\$0	\$2.1M	NA	NA	\$6.9M	\$3.7M	\$4.3M	NA
Total Project Cost (Present Worth)	\$0	\$1.7M	NA	NA	\$6.5M	\$3.3M	\$3.9M	NA

**Table ES.3. Summary of the Comparative Analysis of Alternatives\* (Continued)**

<b>Preliminary Ranking of Alternatives for the C-720 Southeast Site</b>								
	<b>Alternative 1</b>	<b>Alternative 2</b>	<b>Alternative 3</b>	<b>Alternative 4</b>	<b>Alternative 5</b>	<b>Alternative 6</b>	<b>Alternative 7</b>	<b>Alternative 8</b>
<b>Evaluation Criteria</b>	No Further Action	Long-term Monitoring	<i>In situ</i> Chemical Source Treatment Using Deep Soil Mixing	Source Removal and <i>In situ</i> Chemical Source Treatment	<i>In situ</i> Thermal Source Treatment	<i>In situ</i> Source Treatment Using LAI	<i>In situ</i> Soil Flushing and Source Treatment Using Multiphase Extraction	<i>In situ</i> Source Treatment Using Enhanced <i>In situ</i> Bioremediation (EISB)
Overall Protection of Human Health and the Environment	Does not meet the threshold criterion	Meets the threshold criterion	NA	NA	Meets the threshold criterion	Meets the threshold criterion	Meets the threshold criterion	NA
Compliance with ARARs	Does not meet the threshold criterion	Meets the threshold criterion	NA	NA	Meets the threshold criterion	Meets the threshold criterion	Meets the threshold criterion	NA
Long-term effectiveness	Low (1)	Moderate to Low (3)	NA	NA	Moderate to High (7)	Moderate (5)	Moderate to High (7)	NA
Reduction in toxicity, mobility, or volume through treatment	Low (1)	Low (1)	NA	NA	High (9)	Moderate to High (7)	High (9)	NA
Short-term effectiveness	Low (1)	Moderate to Low (3)	NA	NA	Moderate to High (7)	Moderate (5)	Moderate to High (7)	NA
Implementability	High (9)	High (9)	NA	NA	Low (1)	Moderate to Low (3)	Low (1)	NA
Overall cost rating**	High (9)	High (9)	NA	NA	Low (1)	Moderate to Low (3)	Moderate to Low (3)	NA
Average Balancing Criteria Rating	<b>4.2</b>	<b>5</b>	NA	NA	<b>5</b>	<b>4.6</b>	<b>5.4</b>	NA



**Table ES.3. Summary of the Comparative Analysis of Alternatives\* (Continued)**

<b>Preliminary Ranking of Alternatives for the C-720 Southeast Site</b>								
	<b>Alternative 1</b>	<b>Alternative 2</b>	<b>Alternative 3</b>	<b>Alternative 4</b>	<b>Alternative 5</b>	<b>Alternative 6</b>	<b>Alternative 7</b>	<b>Alternative 8</b>
<b>Evaluation Criteria</b>	No Further Action	Long-term Monitoring	<i>In situ</i> Chemical Source Treatment Using Deep Soil Mixing	Source Removal and <i>In situ</i> Chemical Source Treatment	<i>In situ</i> Thermal Source Treatment	<i>In situ</i> Source Treatment Using LAI	<i>In situ</i> Soil Flushing and Source Treatment Using Multiphase Extraction	<i>In situ</i> Source Treatment Using Enhanced <i>In situ</i> Bioremediation (EISB)
Total Project Cost (Escalated)	\$0	\$2.2M	NA	NA	\$7.1M	\$3.8M	\$4.4M	NA
Total Project Cost (Unescalated)	\$0	\$2.1M	NA	NA	\$6.9M	\$3.7M	\$4.3M	NA
Total Project Cost (Present Worth)	\$0	\$1.7M	NA	NA	\$6.5M	\$3.3M	\$3.9M	NA

\*Alternatives 2 through 8 include use of interim LUCs.

\*\*A high overall cost rating corresponds to a low project cost relative to the site evaluated.

NA – Not Applicable. Alternative not retained for further analysis at the associated site due to reasons described in Section 3.5.

LAI – liquid atomization injection

EISB – enhanced *in situ* bioremediation

**Alternative Rating Guide:**

Balancing criteria are scored from 1 (worst) to 9 (best) for each alternative. The qualitative and numerical ratings correspond as follows:

9 – High

7 – Moderate to High

5 – Moderate

3 – Moderate to Low

1 – Low

# 1. INTRODUCTION

This section provides a brief introduction to the Paducah Gaseous Diffusion Plant (PGDP) and an explanation of the purpose and organization of the report. Background information, including the site background and regulatory setting, is summarized. Site and area-specific descriptions including land use, demographics, climate, air quality, noise, ecological resources, and cultural resources are summarized. An overview is provided of the topography, surface water hydrology, geology, and hydrogeology of the region and the study area. A conceptual site model summarizing the nature and extent of contamination and fate and transport modeling of volatile organic compound (VOC) contaminants of concern (COCs) are discussed.

## 1.1 PURPOSE AND ORGANIZATION

This *Revised Focused Feasibility Study for Solid Waste Management Units 1, 211A, and 211B Volatile Organic Compound Sources to the Southwest Groundwater Plume at the Paducah Gaseous Diffusion Plant, Paducah, Kentucky*, DOE/LX/07-0362&D1 (FFS), was prepared to evaluate remedial alternatives for potential application at the U.S. Department of Energy's (DOE's) PGDP. This document has been developed as a revision to the *Focused Feasibility Study for the Southwest Groundwater Plume Volatile Organic Compound Sources (Oil Landfarm and C-720 Northeast and Southeast Sites) at the Paducah Gaseous Diffusion Plant, Paducah, Kentucky* (DOE 2010a). Revisions include the presentation of additional alternatives, which were developed and evaluated as a result of performance data, actual project cost, and implementation information being generated from Phase I of the C-400 Interim Remedial Action.

This work was prepared in accordance with the requirements of the *Federal Facility Agreement for the Paducah Gaseous Diffusion Plant* (FFA) (EPA 1998a); the "Resolution of the Environmental Protection Agency Letter of Non-Concurrence for the Site Investigation Report for the Southwest Plume at the Paducah Gaseous Diffusion Plant, Paducah, Kentucky (DOE/OR/07-2180&D2/R1) and Notice of Informal Dispute Dated November 30, 2007, McCracken County, Kentucky, KY 8-890-008-982" (referred to as the Resolution) (EPA 2008a); and the *Memorandum of Agreement for Resolution of Informal Dispute for the Focused Feasibility Study for the Southwest Plume Volatile Organic Compound Sources Oil Landfarm and C-720 Northeast and Southeast Sites) at the Paducah Gaseous Diffusion Plant, Paducah, KY* (EPA 2010). In addition to the U.S. Environmental Protection Agency (EPA) requirements, National Environmental Policy Act of 1969 (NEPA) values, consistent with the DOE's Secretarial Policy Statement on NEPA in June 1994 (DOE 1994), are evaluated and documented in this FFS. This FFS will be provided to trustee agencies for their review. It is DOE's policy to integrate natural resource concerns early into the investigation and remedy selection process to minimize unnecessary resource injury.

In accordance with Section IV of the FFA, this integrated technical document was developed to satisfy applicable requirements of the Comprehensive Environmental Response, Compensation, and Liability Act (CERCLA) (42 USC 9601 *et seq.* 1980) and the Resource Conservation and Recovery Act (RCRA) (42 USC 6901 *et seq.* 1976). In addition to the EPA requirements, National Environmental Policy Act of 1969 (NEPA) values, consistent with the DOE's Secretarial Policy Statement on NEPA in June 1994 (DOE 1994), are evaluated and documented in this FFS.

This FFS also has been prepared in accordance with the Integrated Feasibility Study/Corrective Measures Study Report outline prescribed in Appendix D of the FFA. As such, this FFS is considered a primary document. All subsections contained in the referenced outline have been included for completeness.

Additional subsections have been added to the outline, as appropriate, and have been included to provide clarity and enhance the organization of the document.

## **1.2 BACKGROUND INFORMATION**

The following section presents information concerning the site background and regulatory setting at the PGDP. It also provides a site description of the PGDP region and source areas, as well as a summary of the process history, nature and extent of contamination, contaminant fate and transport, and the risks associated with the source areas.

### **1.2.1 Site Description**

PGDP is located approximately 10 miles west of Paducah, Kentucky, (population approximately 26,000), and 3.5 miles south of the Ohio River in the western part of McCracken County (Figure 1.1). The plant is located on a DOE-owned site, approximately 650 acres of which are within a fenced security area, approximately 800 acres are located outside the security fence, and the remaining 1,986 acres are licensed to Kentucky as part of the West Kentucky Wildlife Management Area (WKWMA). Bordering the PGDP Reservation to the northeast, between the plant and the Ohio River, is a Tennessee Valley Authority (TVA) reservation on which the Shawnee Fossil Plant is located (Figure 1.2). All plant and process water at PGDP is drawn from the Ohio River.

Before the PGDP was built, a munitions-production facility, the Kentucky Ordnance Works (KOW), was operated at the current PGDP location and at an adjoining area southwest of the site. Munitions, including trinitrotoluene, were manufactured and stored at the KOW between 1942 and 1945. The KOW was shut down immediately after World War II. Construction of PGDP was initiated in 1951 and the plant began operations in 1952. Construction was completed in 1955 and PGDP became fully operational in 1955, supplying enriched uranium for commercial reactors and military defense reactors.

PGDP was operated by Union Carbide Corporation until 1984, when Martin Marietta Energy Systems, Inc. (which later became Lockheed Martin Energy Systems, Inc.), was contracted to operate the plant for DOE. On July 1, 1993, DOE leased the plant production/operations facilities to the United States Enrichment Corporation; however, DOE maintains ownership of the plant and is responsible for environmental restoration and waste management activities. On April 1, 1998, Bechtel Jacobs Company LLC, replaced Lockheed Martin Energy Systems, Inc., in implementing the Environmental Management Program at PGDP. On April 23, 2006, Paducah Remediation Services, LLC, replaced Bechtel Jacobs Company LLC, in implementing the Environmental Management Program at PGDP. On July 26, 2010, LATA Environmental Services of Kentucky, LLC, replaced Paducah Remediation Services, LLC, in implementing the Environmental Management Program at PGDP.

Trichloroethene (TCE), a chlorinated solvent that is a VOC, is the most widespread groundwater contaminant associated with PGDP. The TCE degradation products *cis*-1,2-dichloroethene (*cis*-1,2-DCE), *trans*-1,2-DCE, and vinyl chloride (VC) also are present in some areas. These contaminants have resulted in three dissolved-phase plumes that are migrating from PGDP toward the Ohio River. These groundwater plumes are the Northwest Groundwater Plume [Solid Waste Management Unit (SWMU) 201], the Northeast Groundwater Plume (SWMU 202), and the Southwest Groundwater Plume (SWMU 210) (Figure 1.3).

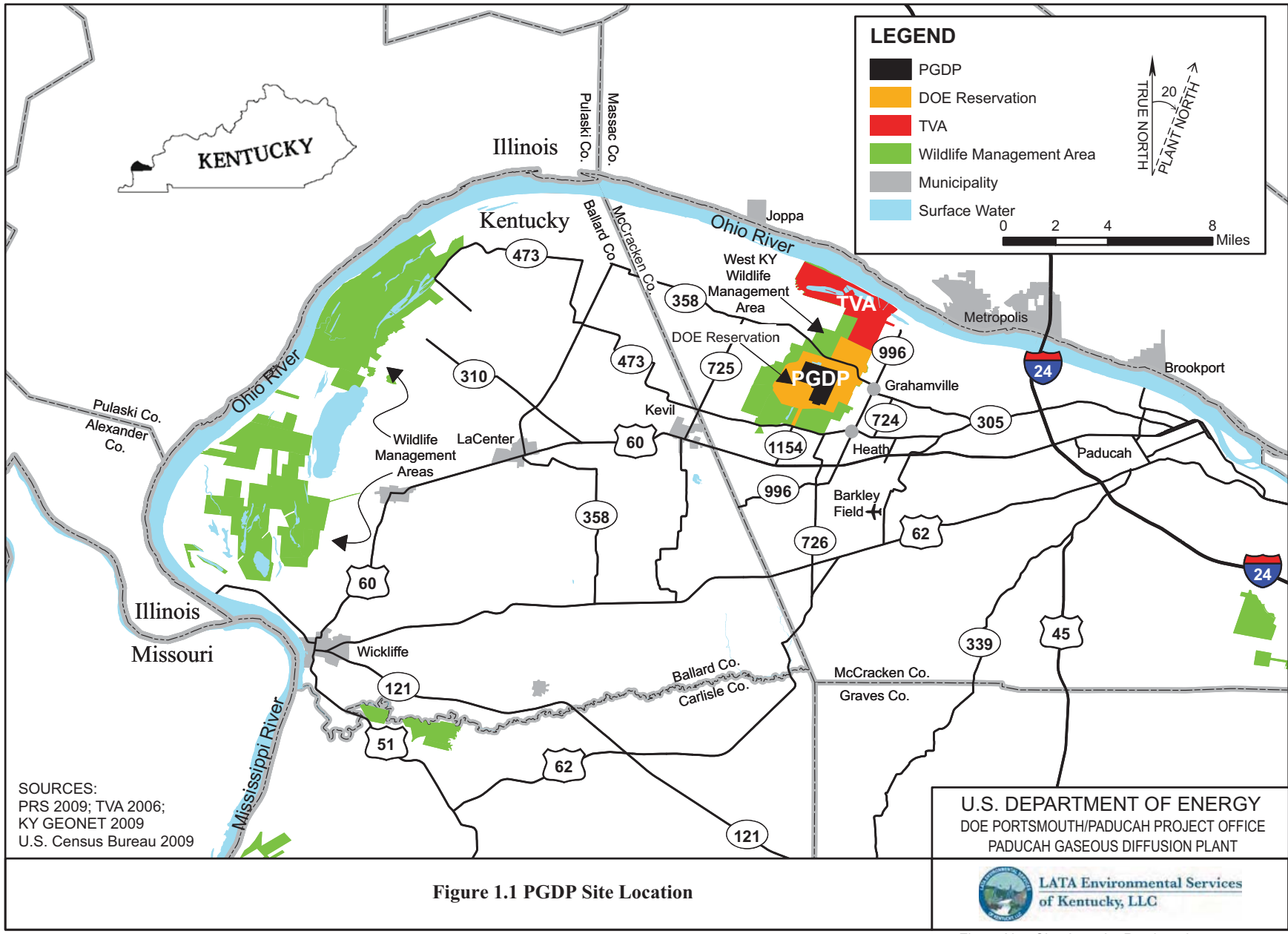

Figure 1.1 PGDP Site Location

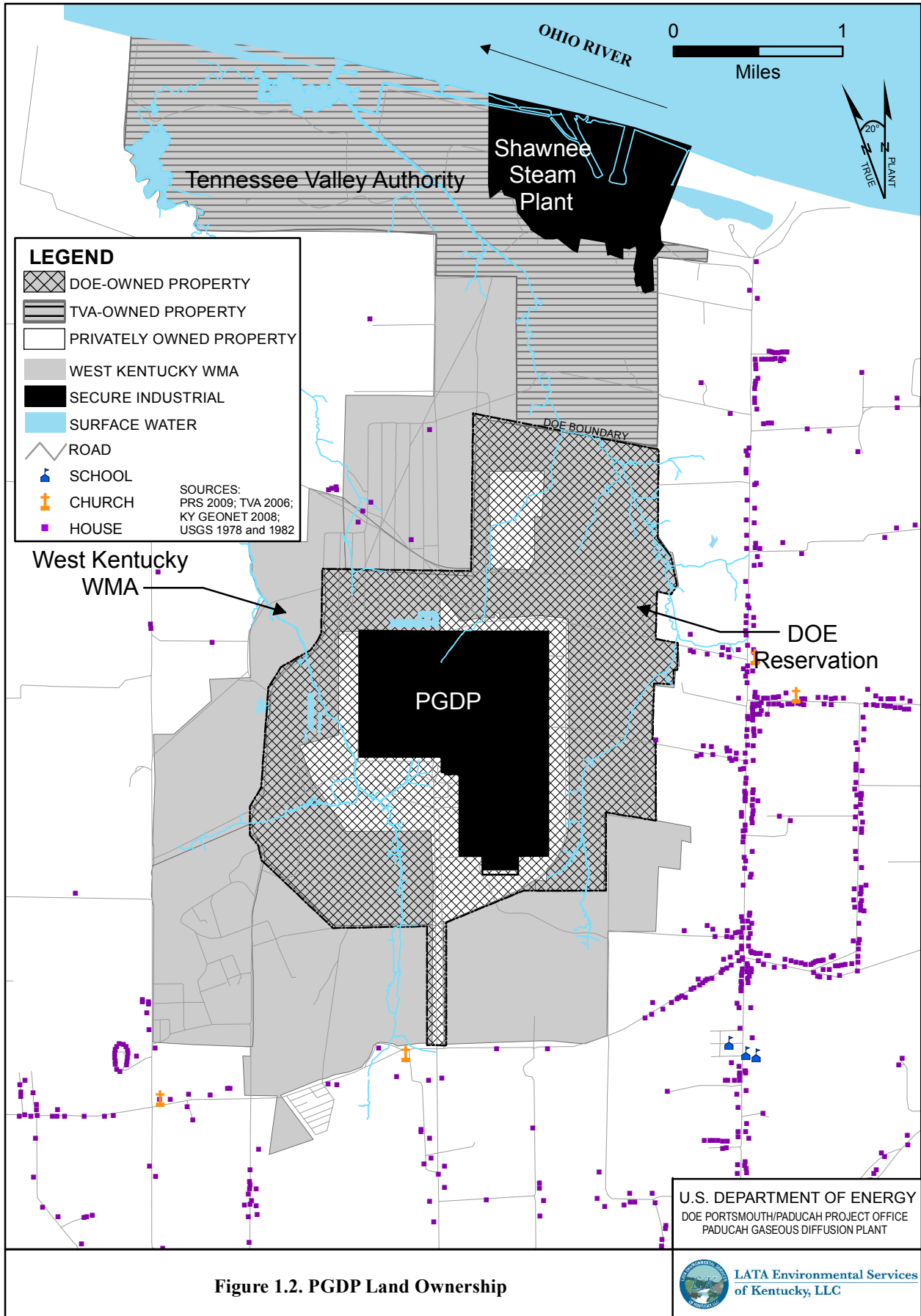
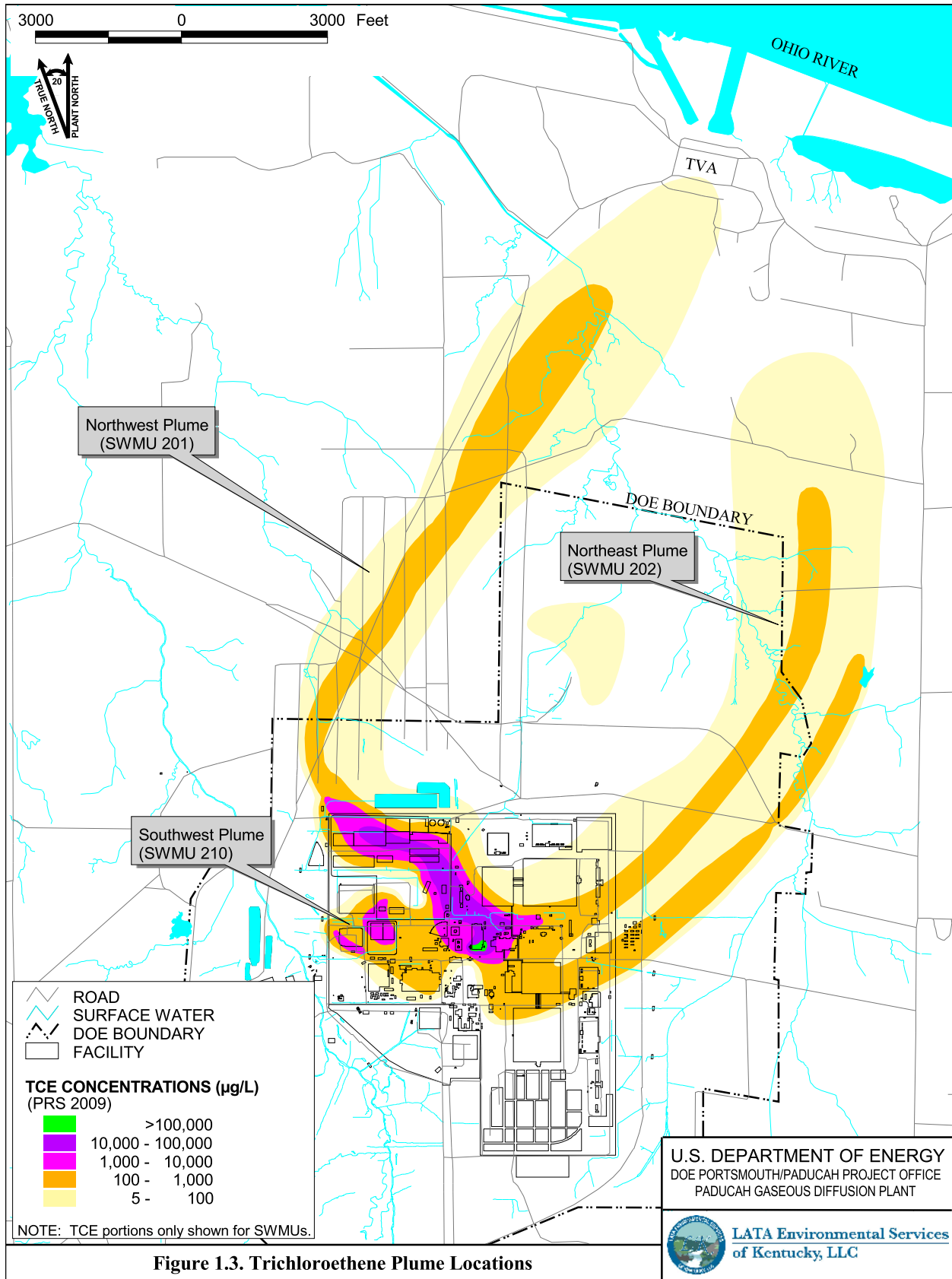

Figure 1.2. PGDP Land Ownership

Figure No. C5AC90005SK043R4.mxd  
 DATE 1-11-2011



**Figure 1.3. Trichloroethene Plume Locations**

Figure No. C5AC90005SK007R3\_5\_1.3.apr  
DATE 1-11-2011

The Southwest Groundwater Plume refers to an area of groundwater contamination at PGDP in the Regional Gravel Aquifer (RGA), which is south of the Northwest Groundwater Plume and west of the C-400 Building. The plume was identified during the Waste Area Grouping (WAG) 27 Remedial Investigation (RI) in 1998. Additional work to characterize the plume (SWMU 210) was performed as part of the WAG 3 RI and Data Gaps Investigations, both in 1999. As discussed in those reports, the primary groundwater COC for the Southwest Groundwater Plume (hereinafter referred to as the Southwest Plume) is TCE. Appendix D contains a discussion of COCs and other contaminants found in the plume including additional VOCs, metals, and radionuclides.

DOE conducted a Site Investigation (SI) in 2004 to address the uncertainties with potential source areas to the Southwest Plume that remained after previous investigations. The SI evaluated potential source areas of contamination to the Southwest Plume and profiled the current level and distribution of VOCs in the dissolved-phase plume along the west plant boundary. Results of the SI were reported in the *Site Investigation Report for the Southwest Groundwater Plume at the Paducah Gaseous Diffusion Plant, Paducah, Kentucky*, DOE/OR/07-2180&D2/R1 (DOE 2007). The FFS is based on the SI as well as previous investigations discussed below.

The potential source areas investigated in the SI included part of the C-747-C Oil Landfarm (Oil Landfarm); C-720 Building areas near the northeast and southeast corners of the building (C-720 Northeast Site and C-720 Southeast Site); and the storm sewer system between the south side of the C-400 Building, Outfall 008 (Storm Sewer). As a result of the Southwest Plume SI, the storm sewer subsequently was excluded as a potential VOC source to the Southwest Plume. SWMU 4 is a source to the Southwest Plume, but will be addressed as part of the Burial Grounds Operable Unit (OU).

Respective SWMU numbers for each potential source area investigated in the SI are provided in Table 1.1. The potential source areas investigated in the Southwest Plume SI are identified in Figure 1.4.

**Table 1.1. Summary of Potential Source Areas and SWMU Numbers**

Description	SWMU No.
C-747-C Oil Landfarm	1
Plant Storm Sewer	Part of 102
C-720 TCE Spill Sites Northeast and Southeast	211 A&B
C-747 Contaminated Burial Yard	4

### 1.2.1.1 Regulatory setting

This section summarizes the framework for environmental restoration at PGDP, including the major acts and accompanying regulations driving response actions, such as the CERCLA, RCRA, and NEPA. It also describes environmental programs and the documents controlling response actions, such as the FFA, the Site Management Plan (SMP) (DOE 2010b), and the Resolution (EPA 2008a). The scope of this action within the overall response strategy for PGDP is described.

**Major Laws, Regulations, and Controlling Documents.** Section 105(a)(8)(B) of CERCLA, as amended by the Superfund Amendments and Reauthorization Act, requires EPA to promulgate a list of national priorities among the known or threatened releases of hazardous substances, pollutants, or contaminants throughout the United States. On June 30, 1994, EPA placed PGDP on the National Priorities List (NPL) [59 *Federal Register (FR)* 27989 (May 31, 1994)]. The NPL lists sites across the country that are

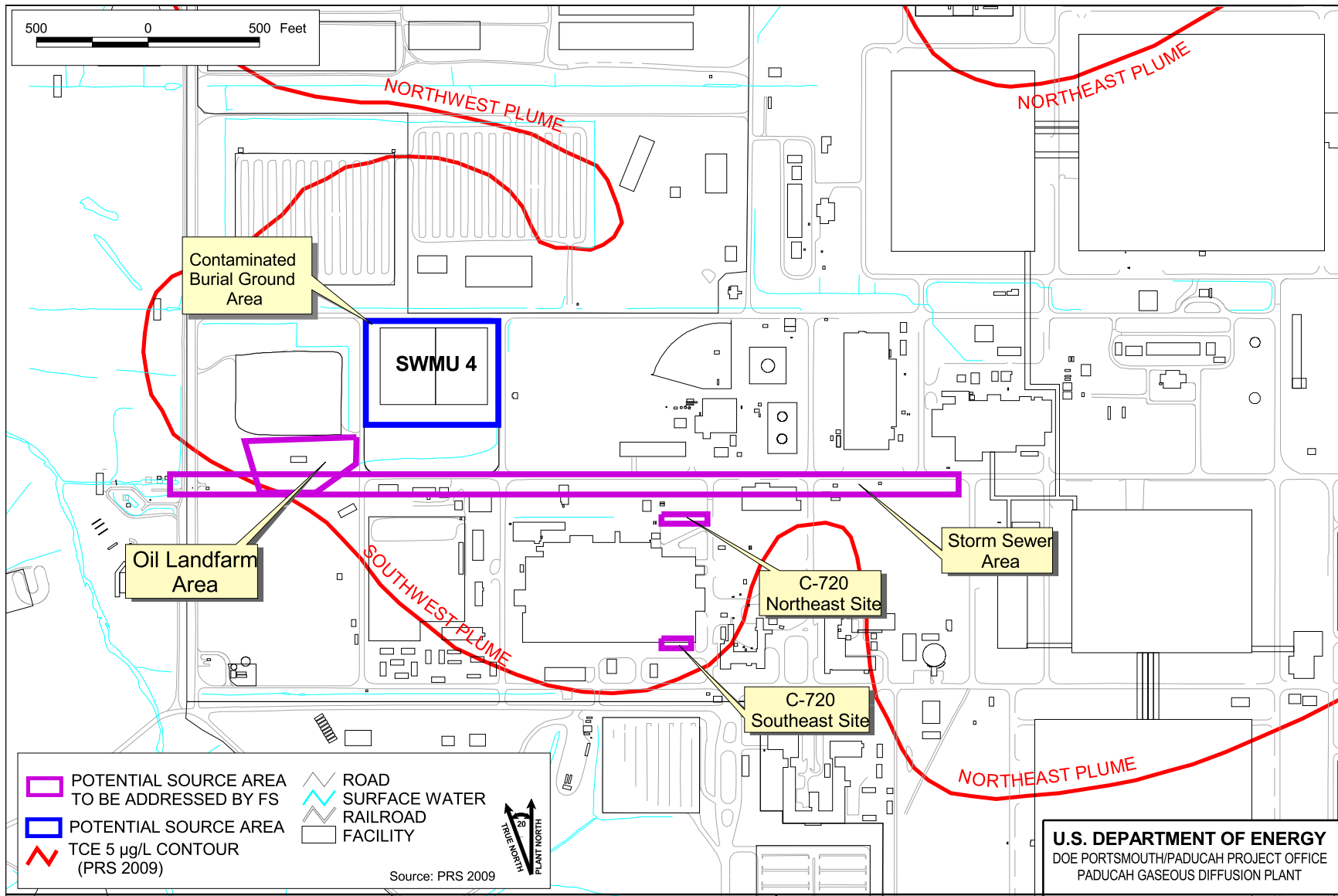

**U.S. DEPARTMENT OF ENERGY**  
 DOE PORTSMOUTH/PADUCAH PROJECT OFFICE  
 PADUCAH GASEOUS DIFFUSION PLANT

**Figure 1.4. Southwest Plume Potential Source Areas**

Figure No. C5AC90005SK007r4\_5\_1.4.apr  
 DATE 1-24-2011





designated by EPA as high priority sites for remediation under CERCLA. As the lead agency under CERCLA, DOE is responsible for conducting cleanup activities at PGDP in compliance with CERCLA, the FFA, the National Oil and Hazardous Substances Pollution Contingency Plan (NCP), and relevant DOE and EPA guidance. The CERCLA is not the only driver for cleanup at PGDP. RCRA requires corrective action for releases of hazardous constituents from SWMUs.

Section 120 of CERCLA requires federal facilities listed on the NPL to enter into an FFA. The purpose of an FFA is to coordinate the CERCLA response action and RCRA corrective action process into a set of comprehensive requirements for site remediation. The FFA requires that DOE develop and submit an annual SMP to EPA and Kentucky Department for Environmental Protection (KDEP). The SMP is intended to provide details necessary or useful in implementing the FFA.

**Environmental Programs.** Environmental sampling at PGDP is a multimedia (air, water, soil, sediment, direct radiation, and biota) program of chemical, radiological, and ecological monitoring. Environmental monitoring consists of two activities: effluent monitoring and environmental surveillance. As part of the ongoing environmental restoration activities, SWMUs and areas of concern have been identified. Characterization and/or remediation of these sites will continue pursuant to the CERCLA and Hazardous and Solid Waste Amendments corrective action conditions of the RCRA Permit.

**National Environmental Policy Act.** The intent of the NEPA is to promote a decision making process that results in minimization of adverse impacts to human health and the environment. On June 13, 1994, the Secretary of Energy issued a Secretarial Policy (Policy) on NEPA that addresses NEPA requirements for actions taken under CERCLA. Section II.E of the Policy indicates that DOE CERCLA documents will incorporate NEPA values, to the extent practicable, such as analysis of cumulative, off-site, ecological, cultural, and socioeconomic impacts.

**Resolution on the Southwest Plume Site Investigation Informal Dispute.** In November 2007, EPA invoked an informal dispute on the Southwest Plume SI. In March 2008, DOE signed the Resolution, which required, among other things, that DOE conduct an FFS for addressing source areas to the Southwest Plume in view of developing remedial alternatives and undertaking a CERCLA remedial action and Record of Decision (ROD) (42 USC 9601 *et seq.* 1980). The source areas subject to the FFS included the Oil Landfarm, C-720 Northeast and Southeast Sites, and Storm Sewer. The FFS was to address contamination in the shallow groundwater and could be based upon the Southwest Plume SI data, previous documents, and additional information, as necessary. The FFS was required to contain, among other information, a remedial action objective (RAO) for addressing source areas, including treatment and/or removal of principal threat waste (PTW) consistent with CERCLA, the NCP (including the preamble), and pertinent EPA guidance. The Southwest dissolved-phase plume in the Groundwater OU Dissolved-Phase Plumes would include the RAO of returning contaminated groundwaters to beneficial use(s) and attaining chemical-specific applicable or relevant and appropriate requirements (ARARs) [e.g., maximum contaminant levels (MCLs) established under the Safe Drinking Water Act] and/or risk-based concentrations for all identified COCs throughout the plume (or at the edge of the waste management area, depending on whether the waste source is removed, consistent with the NCP (including the preamble) and pertinent EPA guidance.

EPA typically describes sources as material that includes hazardous substances, pollutants, or contaminants that act as a reservoir for the groundwater, surface water, or air or act as a source of direct exposure. EPA considers sources or source materials to be principal threats when they are highly toxic or highly mobile and generally cannot be reliably contained or would present a significant risk to human health or the environment should exposure occur (EPA 2004a). Previous investigations of FFS source areas to 55 ft below ground surface (bgs) identified the potential presence of TCE dense nonaqueous-phase liquid (DNAPL), which would constitute PTW.

**Resolution on the Southwest Plume Focused Feasibility Study Informal Dispute.** In April 2010, DOE invoked an informal dispute on the *Focused Feasibility Study for the Southwest Groundwater Plume Volatile Organic Compound Sources (Oil Landfarm and C-720 Northeast and Southeast Sites) at the Paducah Gaseous Diffusion Plant, Paducah, Kentucky* (DOE 2010a). In May 2010, EPA, DOE, and the Kentucky Department for Environmental Protection entered into an agreement resolving the dispute.

**Scope of the Southwest Plume FFS within the Site-wide Groundwater OU.** This FFS will support a final action to mitigate the migration of VOCs at the Oil Landfarm and the C-720 Building Area to the Southwest Plume and to treat or remove PTW. Based on results from the SI further discussed below, the Storm Sewer no longer is considered a source of VOC contamination to the Southwest Plume. Risks posed by direct contact with contaminated surface soil or sediment at the Oil Landfarm and C-720 Building Area or remaining risks from potential use of contaminated groundwater will be addressed later as part of the decisions for the Surface Water, Soils, or Groundwater OUs.

These VOC source areas are assigned to the Groundwater OU at PGDP, which is one of five media-specific site-wide OUs being used to evaluate and implement remedial actions. Consistent with EPA guidance (EPA 2004a), the Groundwater OU is being implemented in a phased approach consisting of sequenced remedial and removal actions designed to accomplish the following goals:

- (1) Prevent human exposure to contaminated groundwater;
- (2) Prevent or minimize further migration of contaminant plumes;
- (3) Prevent, reduce, or control contaminant sources contributing to groundwater contamination; and
- (4) Restore the groundwater to its beneficial uses, wherever practicable.

This FFS and ensuing final VOC remedial action will support the phased groundwater goals represented in goals 3 and 4 above by controlling VOC migration (including DNAPL) that contribute to groundwater contamination, thereby promoting the restoration of groundwater to beneficial use, as practicable. The remedial action also is anticipated to substantially reduce the risk and hazard from hypothetical groundwater use associated with releases from these source areas. Non-VOC soil contamination at the source areas will be addressed by the Soils OU, as described in the 2010 SMP (DOE 2010b). Groundwater contamination will be addressed through the Dissolved-Phase Plumes Remedial Action.

The remedial action alternatives presented were developed based on the information contained in the SI. Uncertainties associated with the extent of VOC contamination that would be subject to remedial action are intended to be addressed during post-ROD/remedial design site investigation (RDSI). The results of the RDSI will provide the detailed basis for remedial action design.

#### **1.2.1.2 Land use, demographics, surface features, and environment**

**Land Use.** The PGDP is heavily industrialized; however, the area surrounding the plant is mostly agricultural and open land, with some forested areas. TVA's Shawnee Steam Plant, adjacent to the northeast border of the DOE Reservation, is the only other major industrial facility in the immediate area. The PGDP is posted government property and trespassing is prohibited. Access to the PGDP site is controlled by guarded checkpoints, a perimeter fence, and vehicle barriers and is subject to routine patrol and visual inspection by plant protective forces. The PGDP site includes 1,986 acres licensed to the Commonwealth of Kentucky Department of Fish and Wildlife Resources. This area is part of the WKWMA and borders PGDP to the north, west, and south. The WKWMA is an important recreational resource for western Kentucky and is used by more than 10,000 people each year. Major recreational activities include hunting, field trials for dogs and horses, trail riding, fishing, and skeet shooting.

**Demographics.** Total population within a 50-mile radius of PGDP is approximately 500,000. Approximately 50,000 people live within 10 miles of PGDP, and homes are scattered along rural roads around the plant. The population of Paducah, based on the 2000 U.S. Census, is 26,307; the total population of McCracken County (251 square miles) is approximately 65,000. The closest communities to PGDP are the unincorporated towns of Grahamville 1 mile to the east and Heath 1 mile southeast. Current and anticipated future land use for PGDP and surrounding areas is depicted in Figure 1.5, taken from the PGDP SMP (DOE 2010b).

**Surface Features and Topography.** PGDP lies in the Jackson Purchase Region of western Kentucky between the Tennessee and Mississippi Rivers, bounded on the north by the Ohio River. The confluence of the Ohio and Mississippi Rivers is approximately 35 miles downstream (southwest) from the site. The confluence of the Ohio and Tennessee Rivers is approximately 15 miles upstream (east) from the site.

Local elevations range from 88.41 m (290 ft) above mean sea level (amsl) along the Ohio River to 137.2 m (450 ft) amsl in the southwestern portion of PGDP near Bethel Church Road. Generally, the topography in the PGDP area slopes toward the Ohio River at an approximate 5.11 m per kilometer (m/km) [27 ft per mile (ft/mile)] gradient (CH2M HILL 1992). Within the plant boundaries, ground surface elevations vary from 109.75 m (360 ft) to 118.9 m (390 ft) amsl. The terrain in the vicinity of the plant is slightly modified by the dendritic drainage systems associated with the two principal streams in the area, Bayou Creek and Little Bayou Creek. These streams have eroded small valleys, which are about 6.09 m (20 ft) below the adjacent plain.

The average pool elevation of the Ohio River is 88.41 m (290 ft) amsl, and the high water elevation is 104.26 m (342 ft) amsl (TCT-St. Louis 1991). Approximately 100 small lakes and ponds exist on DOE property (TCT-St. Louis 1991). A marsh covering 165 acres exists off-site of DOE property, immediately south of the confluence of Bayou Creek and Little Bayou Creek (TCT-St. Louis 1991).

**Climate.** The climate of the region may be broadly classified as humid-continental. The term “humid” refers to the surplus of precipitation versus evapotranspiration that normally is experienced throughout the year. The regional average relative humidity is 76.5% with an average low of reading of 47.5% in January and an average high of 78.0% in August. The 22-year average monthly precipitation is 4.1 inches, varying from an average of 3.3 inches in August (the monthly average low) to an average of 5.0 inches in April (the monthly average high). The total precipitation for 2009 was 55.6 inches, compared to the average of 49.3 inches.

The “continental” nature of the local climate refers to the dominating influence of the North American landmass. Continental climates typically experience large temperature changes between seasons. The mean annual temperature for the Paducah area for 2009 was 57.6 °F. The 22-year average monthly temperature is 57.2°F, with the coldest month being January with an average temperature of 32.6°F and the warmest month being July with an average temperature of 78.8 °F.

The average mean prevailing wind speed is 7.8 miles per hour. Historically, stronger winds are recorded when the winds are from the southwest, averaging 10 miles per hour.

**Air Quality.** PGDP is located in the Paducah-Cairo Interstate Air Quality Control Region of Kentucky, which includes McCracken County and 16 other counties in western Kentucky. Data from the state’s air monitors are used to assess the region’s ambient air quality for the criteria pollutants (ozone, nitrogen oxides, carbon monoxide, particulates, lead, and sulfur dioxide) and to designate nonattainment areas (i.e., those areas for which one or more of the National Ambient Air Quality Standards are not met). McCracken County is classified as an attainment area for all six criteria pollutants [*Fiscal Year 2008*]

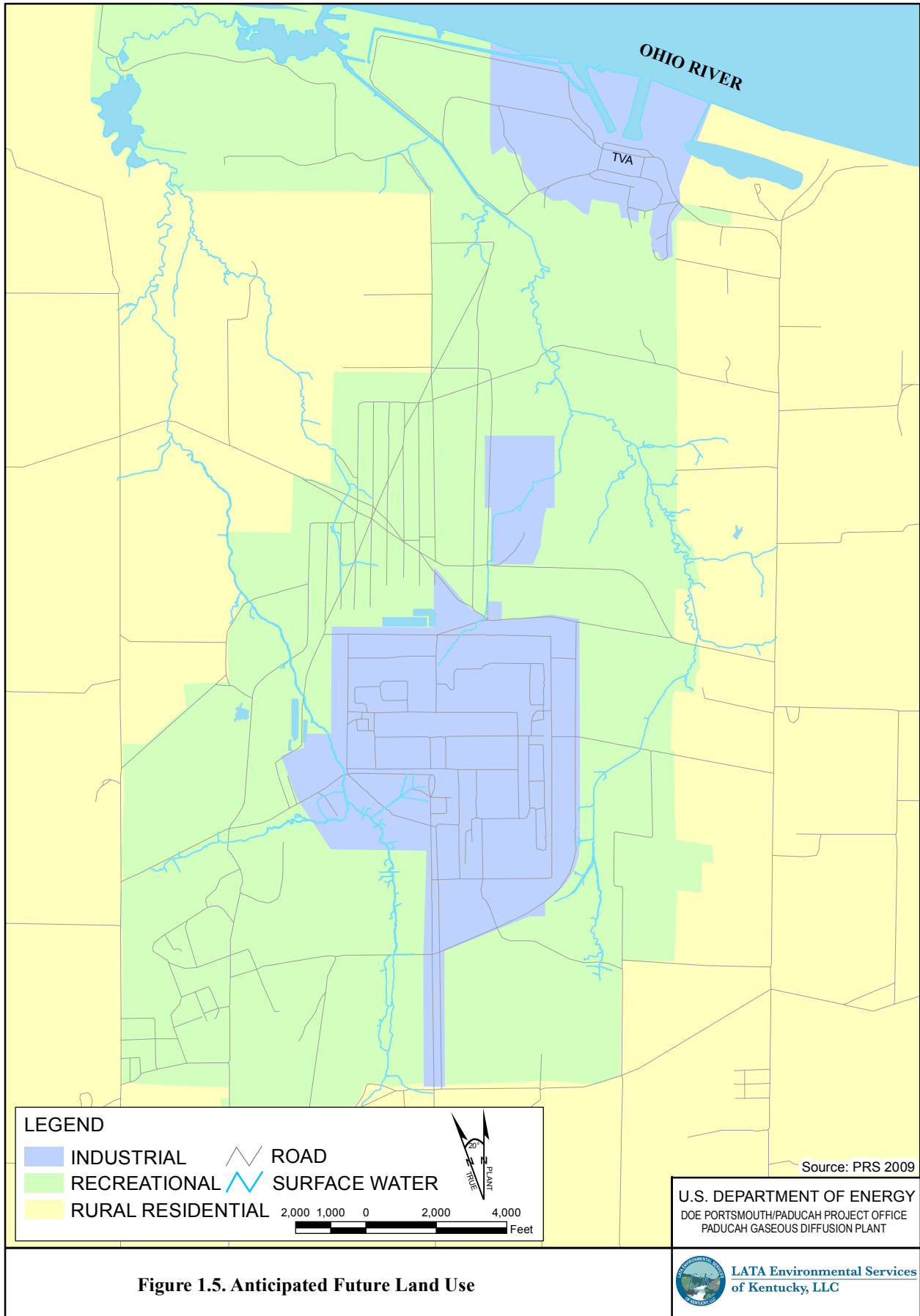

**Figure 1.5. Anticipated Future Land Use**

Figure No. C5AC90005SK007\_1-5b.mxd  
DATE 1-11-2011

*Annual Report* (KDAQ 2008)]. In addition, the United States Enrichment Corporation, which operates PGDP, operates an ambient air monitoring system to assess the impact of various air contaminants emitted by PGDP on the surrounding environment. Ambient air monitoring of radioactive particulates (gross alpha and gross beta) is accomplished by six continuous samplers. Ten additional ambient air sampling stations are operated by the Kentucky Radiation Health Branch to monitor airborne radionuclides from PGDP.

**Noise.** Noises associated with plant activities generally are restricted to areas inside buildings located on-site. Currently, noise levels beyond the security fence are limited to wildlife, hunting, traffic moving through the area, and operation and maintenance (O&M) activities associated with outside waste storage areas located close to the security fence.

### 1.2.1.3 Ecological, cultural, archeological, and historical resources

The following sections give a brief overview of the soils, terrestrial and aquatic systems, wetlands, and cultural resources at PGDP. A more detailed description, including an identification and discussion of sensitive habitats and threatened and endangered (T&E) species, is contained in the *Investigation of Sensitive Ecological Resources Inside the Paducah Gaseous Diffusion Plant, Paducah, Kentucky* (CDM 1994) and the *Environmental Investigations at the Paducah Gaseous Diffusion Plant and Surrounding Area, McCracken County, Kentucky* (COE 1994).

**Soils and Prime Farmland.** Six soil types are associated with PGDP as mapped by the Natural Resources Conservation Service (NRCS), formerly the Soil Conservation Service (USDA 1976). These are Calloway silt loam, Grenada silt loam, Loring silt loam, Falaya-Collins silt loam, Vicksburg silt loam, and Henry silt loam.

The dominant soil types, the Calloway and Henry silt loams, consist of nearly level, somewhat poorly drained to poorly drained soils, that formed in deposits of loess and alluvium. These soils tend to have low organic content, low buffering capacity, and acidic hydrogen-ion concentration (pH) ranging from 4.5 to 5.5. The Henry and Calloway series have a fragipan horizon, a compact and brittle silty clay loam layer that extends from 66 centimeters (26 inches) bgs to a depth of 127 centimeters (50 inches) or more. The fragipan reduces the vertical movement of water and causes a seasonally perched water table in some areas at PGDP. In areas within the PGDP where past construction activities have disturbed the fragipan layer, the soils are best classified as “urban.”

Prime farmland, as defined by the NRCS, is land that is best suited for food, feed, forage, fiber, and oilseed productions, excluding “urban built-up land or water” [7 *CFR* §§ 657 and 658]. The NRCS determines prime farmland based on soil types found to exhibit soil properties best suited for growing crops. These characteristics include suitable moisture and temperature regimes, pH, drainage class, permeability, erodibility factor, and other properties needed to produce sustained high yields of crops in an economical manner. Prime farmland is located north of the PGDP plant area. The prime farmland north of the plant is predominantly located in areas having soil types of Calloway, Grenada, and Waverly.

**Terrestrial Systems.** The terrestrial component of the PGDP ecosystem includes the plants and animals that use the upland habitats for food, reproduction, and protection. The upland vegetative communities consist primarily of grassland, forest, and thicket habitats with agricultural areas. The main crops grown in the PGDP area include soybeans, corn, tobacco, and sorghum.

Most of PGDP has been cleared of vegetation at some time, and much of the grassland habitat currently is mowed by PGDP personnel. A large percentage of the adjacent WKWMA is managed to promote native prairie vegetation by burning, mowing, and various other techniques. These areas have the greatest

potential for restoration and for establishment of a sizeable prairie preserve in the Jackson Purchase area (KSNPC 1991).

Canopy species of the forested areas include oaks, hickories, maples, elms, and sweetgum. Understory species include snowberry, poison ivy, trumpet creeper, Virginia creeper, and Solomon's seal.

Thicket areas consist predominantly of maples, black locust, sumac, persimmon, and forest species in the sapling stage with herbaceous ground cover similar to that of the forest understory.

Wildlife commonly found in the PGDP area consists of species indigenous to open grassland, thicket, and forest habitats. The species documented to occur in the area are discussed in the following paragraphs.

Small mammal surveys conducted on WKWMA documented the presence of southern short-tailed shrew, prairie vole, house mouse, rice rat, and deer mouse (KSNPC 1991). Large mammals commonly present in the area include coyote, eastern cottontail, opossum, groundhog, whitetail deer, raccoon, and gray squirrel.

Typical birds of the area include European starling, cardinal, red-winged blackbird, mourning dove, bobwhite quail, turkey, killdeer, American robin, eastern meadowlark, eastern bluebird, bluejay, red-tail hawk, and great horned owl.

Amphibians and reptiles present include cricket frog, Fowler's toad, common snapping turtle, green tree frog, chorus frog, southern leopard frog, eastern fence lizard, and red-eared slider (KSNPC 1991).

Mist netting activities in the area have captured red bat, little brown bat, Indiana bat, northern long-eared bat, evening bat, and eastern pipistrelle (KSNPC 1991).

**Aquatic Systems.** The aquatic communities in and around PGDP area that could be contaminated by plant discharges include two perennial streams (Bayou Creek and Little Bayou Creek), the North-South Diversion Ditch, a marsh located at the confluence of Bayou Creek and Little Bayou Creek, and other smaller drainage areas. The dominant taxa in all surface waters include several species of sunfish, especially bluegill and green sunfish, as well as bass and catfish. Shallow streams, characteristic of the two main area creeks, are dominated by bluegill, green and longear sunfish, and stonerollers.

**Threatened and Endangered Species.** Potential habitat for federally listed T&E species was evaluated for the area surrounding PGDP during the 1994 U.S. Army Corps of Engineers (COE) environmental investigation of the PGDP (COE 1994) and inside the fence of the PGDP during the 1994 investigation of sensitive resources at the PGDP (CDM 1994). Investigation inside the PGDP security fence did not detect any T&E species or their preferred habitats, and the U.S. Fish and Wildlife Service has not designated critical habitat for any species within DOE property.

**Cultural, Archaeological, and Historic Resources.** In accordance with the National Historic Preservation Act (NHPA), a Programmatic Agreement among the DOE Paducah Site Office, the Kentucky State Historic Preservation Officer, and the Advisory Council on Historic Preservation Concerning Management of Historical Properties was signed in January 2004. DOE developed the *Cultural Resources Management Plan for the Paducah Gaseous Diffusion Plant, Paducah Gaseous Diffusion Plant, McCracken County, Kentucky* (CRMP) (BJC 2006) to define the preservation strategy for PGDP and direct efficient compliance with the NHPA and federal archaeological protection legislation at PGDP. PGDP facilities are documented with survey forms and photographs in the *Cultural Resources Survey for the Paducah Gaseous Diffusion Plant, Paducah, Kentucky*, BJC/PAD-688/R1. No archaeological resources have been identified within the vicinity of the facilities identified as sources for

the Southwest Groundwater Plume. If portions of the project remove soils that previously have been undisturbed, in accordance with the CRMP, an archaeological survey will be conducted. If archaeological properties are identified and will be affected adversely, appropriate mitigation measures will be employed.

#### **1.2.1.4 Surface water hydrology, wetlands, and floodplains**

**Surface Water Hydrology.** PGDP is located in the western portion of the Ohio River drainage basin, approximately 24 km (15 miles) downstream of the confluence of the Ohio River with the Tennessee River and approximately 56 km (35 miles) upstream of the confluence of the Ohio River with the Mississippi River. Locally, the PGDP is within the drainage areas of the Ohio River, Bayou Creek (also known as Big Bayou Creek), and Little Bayou Creek.

The plant is situated on the divide between the two creeks. Surface flow is east-northeast toward Little Bayou Creek and west-northwest toward Bayou Creek. Bayou Creek is a perennial stream on the western boundary of the plant that flows generally northward, from approximately 2.5 miles south of the plant site to the Ohio River along a 14.5-km (9-mile) course. The Little Bayou Creek drainage originates within WKWMA and extends northward and joins Bayou Creek near the Ohio River along a 10.5-km (6.5-mile) course.

Most of the flow within Bayou and Little Bayou Creeks is from process effluents or surface water runoff from PGDP. Plant discharges are monitored at the Kentucky Pollutant Discharge Elimination System (KPDES) outfalls prior to discharge into the creeks.

**Wetlands.** The 1994 COE environmental investigations identified 1,083 separate wetland areas and grouped them into 16 vegetative cover types encompassing forested, scrub/shrub, and emergent wetlands (COE 1994). Wetland vegetation consists of species such as sedges, rushes, spikerushes, and various other grasses and forbs in the emergent portions; red maple, sweet gum, oaks, and hickories in the forested portions; and black willow and various other saplings of forested species in the thicket portions.

Five acres of potential wetlands were identified inside the fence at PGDP (COE 1995). The COE made the determination that these areas are jurisdictional wetlands. Wetlands inside the plant security fence are confined to portions of drainage ditches traversing the site. These areas provide some groundwater recharge, floodwater retention, and sediment retention. While the opportunity for these functions and values is high, the effectiveness is low due to water exiting the area quickly through the drainage system. Other functions and values (e.g., wildlife benefits, recreation, diversity, etc.) are very low.

**Floodplains.** Floodplains were evaluated during the 1994 COE environmental investigation of PGDP (COE 1994). This evaluation used the Hydrologic Engineering Center Computer Program-2 model to estimate 100- and 500-year flood elevations. Flood boundaries from the Hydrologic Engineering Center Computer Program-2 model were delineated on topographic maps of the PGDP area to determine areal extent of the flood waters associated with these events.

Flooding is associated with the Ohio River, Bayou Creek, and Little Bayou Creek. The majority of overland flooding at PGDP is associated with storm water runoff and flooding from Bayou and Little Bayou Creeks. A floodplain analysis performed by COE (1994) found that much of the built-up portions of the plant lie outside the 100- and 500-year floodplains of these streams. Drainage ditches inside the PGDP security fence can contain nearly all of the expected 100- and 500-year flood discharges (COE 1994). It should be noted that precipitation frequency estimates for the 100- and 500-year events were updated in 2004 in the National Oceanic and Atmospheric Administration's (NOAA) Atlas 14 (NOAA 2004). In the updated report, the mean precipitation estimate for the 100-year, 24-hour event in

Atlas 14 for the Paducah area is 10.1% to 15% greater than the mean estimate in previous publications. As stated in Atlas 14, in many cases, the mean precipitation estimate used previously still is within the confidence limits provided in Atlas 14; therefore, it is assumed the plant ditches still will contain the 100- and 500-year discharges.

### **1.2.1.5 Regional and study area geology and hydrogeology**

**Regional Geology.** PGDP is located in the Jackson Purchase Region of Western Kentucky, which represents the northern tip of the Mississippi Embayment portion of the Coastal Plain. The Jackson Purchase Region is an area of land that includes all of Kentucky west of the Tennessee River. The stratigraphic sequence in the region consists of Cretaceous, Tertiary, and Quaternary sediments unconformably overlying Paleozoic bedrock. Figure 1.6 summarizes the geologic and hydrogeologic systems of the PGDP region.

Within the Jackson Purchase Region, strata deposited above the Precambrian basement rock attain a maximum thickness of 3,659 to 4,573 m (12,000 to 15,000 ft). Exposed strata in the region range in age from Devonian to Holocene. The Devonian stratum crops out along the western shore of Kentucky Lake.

Mississippian carbonates form the nearest outcrop of bedrock and are exposed approximately 14.5 km (9 miles) northwest of PGDP in southern Illinois (Clausen *et al.* 1992). The Coastal Plain deposits unconformably overlie Mississippian carbonate bedrock and consist of the following: the Tuscaloosa Formation; the sand and clays of the Clayton/McNairy Formations; the Porters Creek Clay; and the Eocene sand and clay deposits (undivided Jackson, Claiborne, and Wilcox Formations). Continental Deposits unconformably overlie the Coastal Plain deposits, which are, in turn, covered by loess and/or alluvium.

Relative to the shallow groundwater flow system in the vicinity of PGDP, the Continental Deposits and the overlying loess and alluvium are of key importance. The Continental Deposits resemble a large low-gradient alluvial fan that covered much of the region and eventually buried the erosional topography. A principal geologic feature in the PGDP area is the Porters Creek Clay Terrace, a subsurface terrace that trends approximately east to west across the southern portion of the plant. The Porters Creek Clay Terrace represents the southern limit of erosion or scouring of the ancestral Tennessee River. Thicker sequences of Continental Deposits, as found underlying PGDP, represent valley fill deposits and can be informally divided into a lower unit (gravel facies) and an upper unit (clay facies). The Lower Continental Deposit (LCD) is the gravel facies consisting of chert gravel in a matrix of poorly sorted sand and silt that rests on an erosional surface representing the beginning of the valley fill sequence. In total, the gravel units average approximately 9.14 m (30 ft) thick, but some thicker deposits [as much as 15.25 m (50 ft)] exist in deeper scour channels. The Upper Continental Deposit (UCD) is primarily a sequence of fine-grained, clastic facies varying in thickness from 4.6 to 18.3 m (15 to 60 ft) that consist of clayey silts with lenses of sand and occasional gravel. The Upper Continental Recharge System (UCRS) is comprised of alluvial deposits, which vary considerably in grain size and porosity. Based on geologic logs, the lithology reflects facies changes that range from silt to sand to clay. Some logs indicate clay is present from land surface to the top of the RGA, which confines the aquifer. Other logs indicate there are areas where only silt and sand are present from land surface to the top of the RGA, so the RGA is unconfined in these areas. The RGA receives recharge most readily in the unconfined areas. These areas may serve as pathways for contaminant migration from the UCRS to the RGA.

The area of the Southwest Plume lies within the buried valley of the ancestral Tennessee River in which Pleistocene Continental Deposits (the fill deposits of the ancestral Tennessee River Basin) rest unconformably on Cretaceous marine sediments. Pliocene through Paleocene formations in the area of the Southwest Plume have been removed by erosion from the ancestral Tennessee River Basin. In the area of the Southwest Plume and its sources, the upper McNairy Formation consists of 18.3 to 21.3 m (60 to



SYSTEM	SERIES	FORMATION	THICKNESS (IN FEET)	DESCRIPTION	HYDROGEOLOGIC SYSTEMS
<b>QUATERNARY</b>	<b>PLEISTOCENE AND RECENT</b>	<b>ALLUVIUM</b>	<b>0-40</b>	Brown or gray sand and silty clay or clayey silt with streaks of sand.	<b>Upper Continental Recharge System</b>
	<b>PLEISTOCENE</b>	<b>LOESS</b>	<b>0-43</b>	Brown or yellowish-brown to tan unstratified silty clay.	
	<b>PLEISTOCENE</b>	<b>CONTINENTAL DEPOSITS</b>	<b>3-121</b>	Upper Continental Deposits (Clay Facies) - mottled gray and yellowish brown to brown clayey silt and silty clay, some very fine sand, trace of gravel. Often micaceous.	
<b>PLIOCENE-MIOCENE (?)</b>	Lower Continental Deposits (Gravel Facies) - reddish-brown clayey, silty and sandy chert gravel and beds of gray sand.			<b>Regional Gravel Aquifer</b>	
<b>TERTIARY</b>	<b>EOCENE</b>	<b>JACKSON, CLAIBORNE, AND WILCOX FORMATIONS</b>	<b>0-200+</b>	Red, brown or white fine to coarse grained sand. Beds of white to dark gray clay are distributed at random.	<b>McNairy Flow System</b>
			<b>0-100+</b>	White to gray sandy clay, clay conglomerates and boulders, scattered clay lenses and lenses of coarse red sand. Black to dark gray lignitic clay, silt or fine grained sand.	
	<b>PALEOCENE</b>	<b>PORTERS CREEK CLAY</b>	<b>0-200</b>	Dark gray, slightly to very micaceous clay. Fine grained clayey sand, commonly glauconitic in the upper part. Glauconitic sand and clay at the base.	
			<b>Undetermined</b>	Lithologically similar to underlying McNairy Formation.	
<b>UPPER CRETACEOUS</b>		<b>McNAIRY FORMATION</b>	<b>200-300</b>	Grayish-white to dark gray micaceous clay, often silty, interbedded with light gray to yellowish-brown very fine to medium grained sand with lignite and pyrite. The upper part is interbedded clay and sand, and the lower part is sand.	
		<b>TUSCALOOSA FORMATION</b>	<b>Undetermined</b>	White, well rounded or broken chert gravel with clay.	
<b>MISSISSIPPIAN</b>		<b>MISSISSIPPIAN CARBONATES</b>	<b>500+</b>	Dark gray limestone and interbedded chert, some shale.	

Adapted from Olive 1980.

U.S. DEPARTMENT OF ENERGY  
DOE PORTSMOUTH/PADUCAH PROJECT OFFICE  
PADUCAH GASEOUS DIFFUSION PLANT



LATA Environmental Services  
of Kentucky, LLC

Figure 1.6. Generalized Lithostratigraphic Column of the PGDP Region

70 ft) of interbedded units of silt and fine sand and underlies the Continental Deposits. Total thickness of the McNairy Formation is approximately 68.6 m (225 ft).

The surface deposits found in the vicinity of PGDP consist of loess and alluvium. Both units are composed of clayey silt or silty clay and range in color from yellowish-brown to brownish-gray or tan, making field differentiation difficult.

**Regional Hydrogeology.** The local groundwater flow system at the PGDP site occurs within the sands of the Cretaceous McNairy Formation, Pliocene terrace gravels, Plio-Pleistocene lower continental gravel deposits and upper continental deposits, and Holocene alluvium (Jacobs EM Team 1997; MMES 1992). Four specific components have been identified for the groundwater flow system and are defined as follows from lowest to uppermost.

- (1) **McNairy Flow System.** Formerly called the deep groundwater system, this component consists of the interbedded and interlensing sand, silt, and clay of the Cretaceous McNairy Formation. Sand facies account for 40% to 50% of the total formation's thickness of approximately 68.6 m (225 ft). Groundwater flow is predominantly north.
- (2) **Terrace Gravel.** This component consists of Pliocene(?) -aged gravel deposits (a question mark indicates uncertain age) and later reworked sand and gravel deposits found at elevations higher than 97.5 m (320 ft) amsl in the southern portion of the plant site; they overlie the Paleocene Porters Creek Clay and Eocene sands. These deposits usually lack sufficient thickness and saturation to constitute an aquifer. Terrace Gravel is not present in the area of the Southwest Plume sources.
- (3) **RGA.** This component consists of the Quaternary sand and gravel facies of the LCDs and Holocene alluvium found adjacent to the Ohio River and is of sufficient thickness and saturation to constitute an aquifer. These deposits are commonly thicker than the Pliocene(?) gravel deposits, having an average thickness of 9.1 m (30 ft), and range up to 15.24 m (50 ft) in thickness along an axis that trends east-west through the plant site. Prior to 1994, the RGA was the primary aquifer used as a drinking water source by nearby residents. The RGA has not been formally classified, but likely would be considered a Class II groundwater under EPA Groundwater Classification guidance (EPA 1986). Groundwater flow is predominantly north toward the Ohio River.
- (4) **Upper Continental Recharge System.** The UCRS consists of the surficial alluvium and UCDs. Sand and gravel lithofacies appear relatively discontinuous in cross-section, but portions may be interconnected. The most prevalent sand and gravel deposits occur at an elevation of approximately 105.2 to 106.9 m (345 to 351 ft) amsl; less prevalent deposits occur at elevations of 102.7 to 103.9 m (337 to 341 ft) amsl. Groundwater flow is predominantly downward into the RGA from the UCRS, which has a limited horizontal component in the vicinity of PGDP. The UCRS is comprised of alluvial deposits, which vary considerably in grain size and porosity. Based on geologic logs, the lithology reflects facies changes that range from silt to sand to clay. Some logs indicate clay is present from land surface to the top of the RGA, which confines the aquifer. Other logs indicate there are areas where only silt and sand are present from land surface to the top of the RGA, so the RGA is unconfined in these areas. The RGA receives recharge most readily in the unconfined areas. These areas may serve as pathways for contaminant migration from the UCRS to the RGA.

The primary groundwater flow systems associated with the Southwest Plume are the UCRS and the RGA. Figure 1.7 shows the different water-bearing zones and their relationships in the PGDP area. In the area of the Southwest Plume, groundwater flow and contaminant migration through the upper 13.7 to 16.76 (45 to 55 ft) of subsurface soil (UCD) is predominantly downward with little lateral spreading. This flow system is termed the UCRS. Locally, the UCRS consists of three hydrogeologic units (HUs), an upper silt

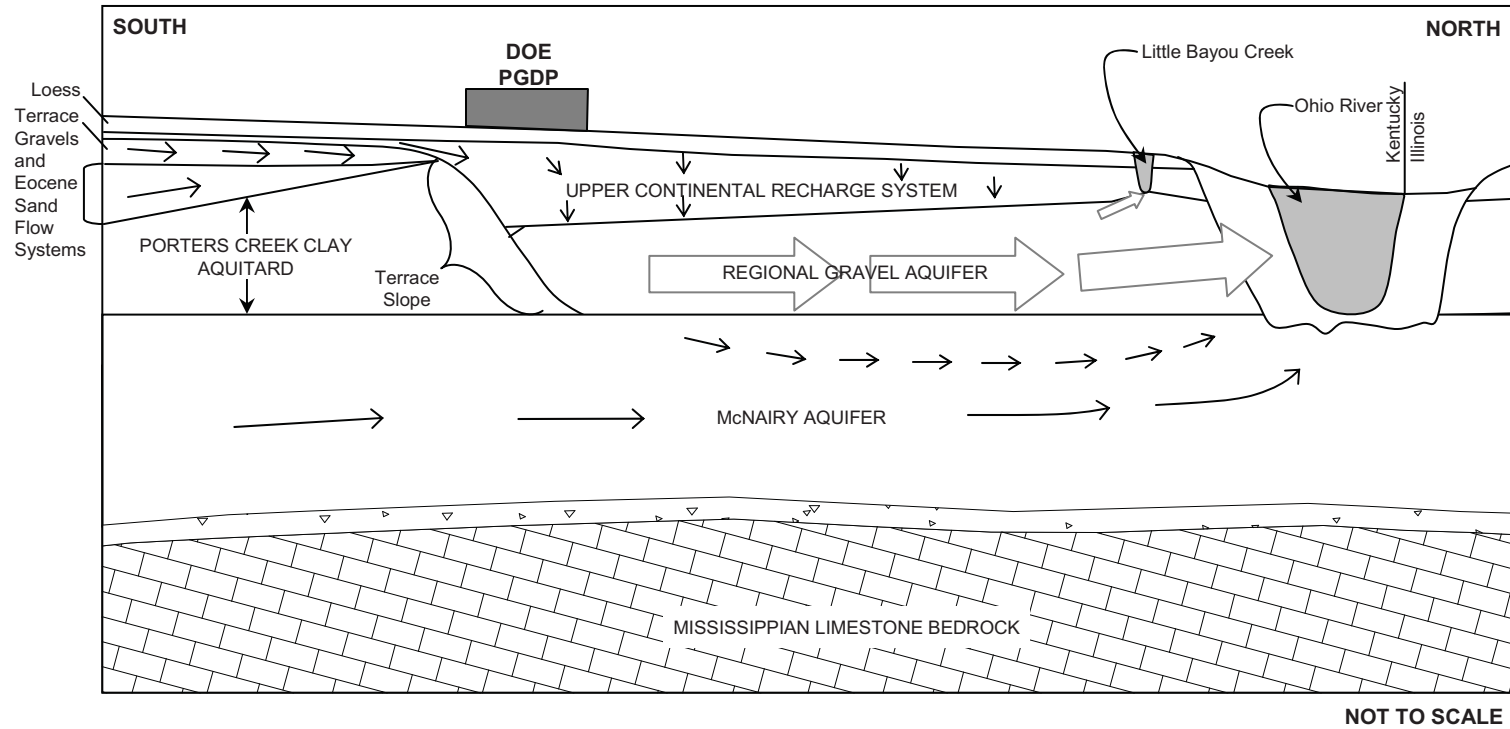

Source: PRS 2009

U.S. DEPARTMENT OF ENERGY  
DOE PORTSMOUTH/PADUCAH PROJECT OFFICE  
PADUCAH GASEOUS DIFFUSION PLANT

Figure 1.7. Water-Bearing Zones near the PGDP



interval (HU1), an intermediate horizon of sand and gravel lenses (HU2), and a lower silt and clayey silt interval (HU3). Groundwater flow rates in the UCRS tend to be on the order of 0.03 m per day [0.1 ft per day (ft/day)]. The silts and clays of the UCRS readily adsorb some contaminants, such as many metals and radionuclides, retarding the migration of these contaminants in groundwater from the source areas. Moreover, laterally extensive silt and clay horizons in the UCRS may halt the downward migration of DNAPLs, but foster the development of DNAPL pools in the subsurface.

Groundwater occurrence in the UCRS is primarily the result of infiltration from natural and anthropogenic recharge. Flow is predominantly downward. Groundwater in the UCRS provides recharge to the underlying RGA. The water table in the UCRS varies both spatially and seasonally due to lithologic heterogeneity and recharge factors (infiltration of focused run-off from engineered surfaces, seepage due to variations in cooling water line integrity, rainfall and evapotranspiration), and averages approximately 5.2 m (17 ft) in depth with a range of 0.61 to 15.25 m (2 to 50 ft).

Downward vertical hydraulic gradients generally range from 0.15 to 0.30 m per m (0.5 to 1 ft per ft) where measured by monitoring wells (MWs) completed at different depths in the UCRS. Monitoring wells in the south-central area of PGDP (south of the C-400 Building and east of the C-720 Building) have lower water level elevations than MWs in other areas of the plant (DOE 1997). Hydraulic conductivity in the UCRS has been determined from numerous slug tests in a previous investigation (CH2M HILL 1992). Hydraulic conductivity ranges from 1.0E-08 to 6.9E-04 centimeters per second (cm/s) [3.9E-09 to 2.7E-04 inches/second (in/s)] with a geometric mean of 1.4E-05 cm/s (5.5E-06 in/s). It should be noted that one pumping test has been performed in the UCRS. The pumping well W-1 was able to sustain a withdrawal rate of 0.01 gal per minute via a peristaltic pump, which is equivalent to approximately 15 gal per day.

A thick interval of late Pleistocene sand and gravel from a depth interval of 18.3 to 27.4 m (60 to 90 ft) (LCD) represents the shallow, uppermost aquifer underlying most of PGDP, referred to as the RGA. The RGA consists of a discontinuous upper horizon of fine to medium sand (HU4) and a lower horizon of medium to coarse sand, and gravel (HU5). The RGA is the main pathway for lateral flow and dissolved contaminant migration off-site. Variations in hydraulic conductivity and the location of discrete sources of recharge govern the local direction and rate of groundwater flow; however, overall flow within the RGA trends north-northeast toward the Ohio River, which represents the regional hydraulic base level.

Appendix C describes the process used for this FFS to determine the location of the HU3/HU4 contact at the Southwest Plume source areas, based on lithologic logs for boreholes and MWs provided in the WAG 27 RI (DOE 1999a) and the SI Report (DOE 2007). The location of the contact was used in modeling migration of contaminants from the source areas to the RGA. The location of the contact was determined using the following evaluation steps:

- (1) Locate the gravel layer in the RGA in the well logs.
- (2) Locate the sand layers above the gravel layer.
- (3) The top of the HU4 layer, where present, is considered to be the top of the saturated sand unit, not containing significant silts or clays, immediately overlying the HU5 gravel layer. If the HU4 is not present, then the top of the HU5 gravel is considered to be the contact.

The methodology for choosing the HU3/HU4 contact considers the clay content of the sand layer because significant clay content would reduce the capacity of the sand to the extent that its hydraulic properties would be more similar to the HU3 unit. Table C.2 and Figure C.1 of Appendix C provide the Oil Landfarm location of the HU3/HU4 contact location based on the well logs. The average location of the

HU3/HU4 contact is at 53 ft below the surface at the Oil Landfarm. Table C.3 and Figure C.2 of Appendix C provide the C-720 location of the HU3/HU4 contact location based on the well logs. The average location of the HU3/HU4 contact is at 58.4 ft below the surface at C-720.

The RGA typically has a high hydraulic conductivity with a range from 1.9E-02 to 2.0E+00 cm/s (7.5E-03 to 7.9E-01 in/s) as determined from aquifer testing. RGA horizontal hydraulic gradients range between  $1.84 \times 10^{-4}$  and  $2.98 \times 10^{-3}$  ft/ft and have average and median values of  $7.81 \times 10^{-4}$  and  $4.4 \times 10^{-4}$  ft/ft, respectively. Groundwater flow rates within the RGA average approximately 1 to 3 ft/day. Contaminant migration tends to be less retarded in the coarse sediments of the RGA due to its high groundwater flow rate and also due to the low fraction of organic carbon (0.02%).

**Study Area Geology.** The geologic layers at the Oil Landfarm consist primarily of silt/sandy/silty sand with some clay (DOE 2007). This is indicative of the UCD overlaid with surface soil. In general, the subsurface soils typically are silts to a depth of 7.6 to 9.14 m (25 to 30 ft). Sand is common below a depth of 9.14 m (30 ft). The lower portion of the UCD often exhibits a noticeable increase in grain size and a significant increase in moisture content consistent with the contact between the UCD and the LCD. A geologic cross-section in the general area of the Oil Landfarm is provided in Figure 1.8. A cross-section in the immediate area of the Oil Landfarm is provided in Figure 1.9.

The geologic strata found in the C-720 Building Area range from clays to silts to sands. Silt and clay are the predominant subsurface soil texture to a depth of 4.6 to 6.1 m (15 to 20 ft). Interbedded sand and clay units are commonly found below those depths. Clay and sandy clay/clayey sand are present near the bottom of most of the soil borings northeast of C-720 Building (DOE 2007). A geologic cross-section in the general area of the C-720 Northeast Site is provided in Figure 1.10. A cross-section in the immediate area of the C-720 Northeast Site is provided in Figure 1.11.

Immediately southeast of the C-720 Building silt and clay are present to a depth of 15 ft with interbedded sand and clay layers found at deeper horizons. Medium-to-coarse-grained sand, suggestive of the contact between the UCDs and LCDs, was encountered near the bottom of borings in the southeast corner. A geologic cross-section in the general area of the C-720 Southeast Site is provided in Figure 1.10. A cross-section in the immediate area of the C-720 Southeast Site is provided in Figure 1.12.

The Southwest Plume investigation of the Storm Sewer included 15 soil borings (DOE 2007). Each boring was placed as closely to the Storm Sewer as possible in an attempt to collect soil samples from the base of the backfill material in which the Storm Sewer rests. Borings did not exceed 6.1 m (20 ft) in depth. The soil cores consisted primarily of silt and clay with occasional lenses of sand toward the bottom of the sample interval. Because this was an area of construction, the majority of the sediments encountered bgs were possibly backfill material.

**Study Area Hydrogeology.** The Southwest Plume SI included soil sampling within the upper 18.3 m (60 ft) of the Oil Landfarm. Soil samples verified the presence of the HU1, HU2, and HU3 members of the UCRS. The UCRS is comprised of alluvial deposits, which vary considerably in grain size and porosity. Based on geologic logs, the lithology reflects facies changes that range from silt to sand to clay. Some logs indicate clay is present from land surface to the top of the RGA, which confines the aquifer. Other logs indicate there are areas where only silt and sand are present from land surface to the top of the RGA, so the RGA is unconfined in these areas. The RGA receives recharge most readily in the unconfined areas. These areas may serve as pathways for contaminant migration from the UCRS to the RGA. HU3 sediments tended to be coarser grained than typical. The RGA was not encountered, although the final interval sampled 16.76 to 18.3 m (55 to 60 ft) often revealed a noticeable increase in grain size and a

**A**  
**NORTHWEST**  
 ELEVATION  
 (FT/AMSL)

**A'**  
**SOUTHEAST**  
 ELEVATION  
 (FT/AMSL)

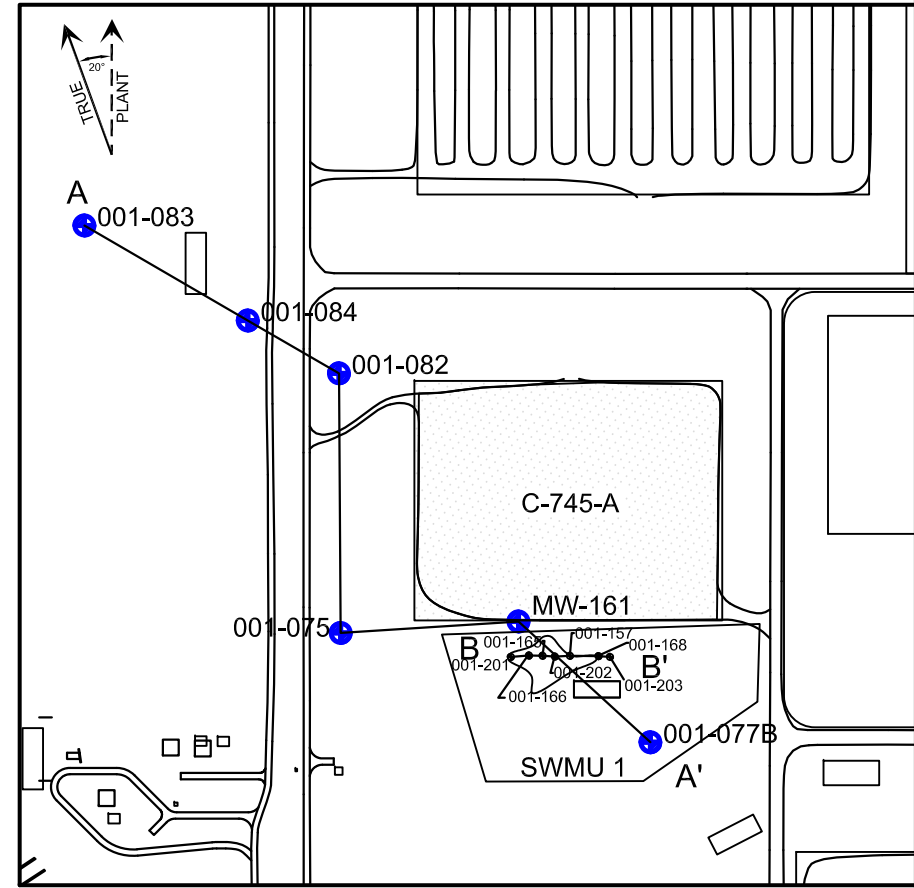
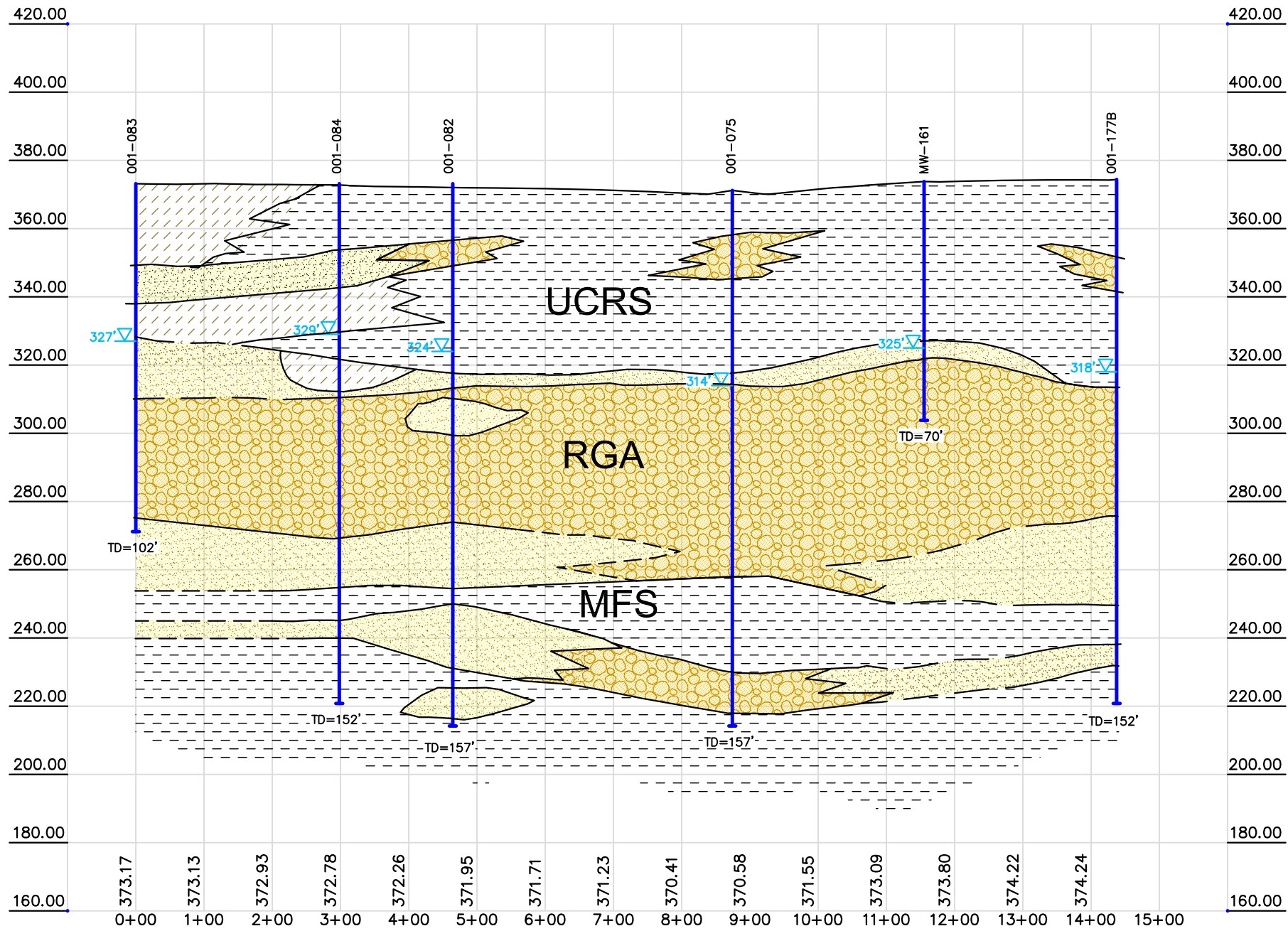

**LOCATION MAP**  
 SCALE: 1" = 300'

**LEGEND**

- CLAY
- GRAVEL
- SAND
- SILT
- WATER LEVEL AT TIME OF GEOPHYSICAL LOG
- DASHED WHERE INFERRED
- UCRS - UPPER CONTINENTAL RECHARGE SYSTEM
- RGA - REGIONAL GRAVEL AQUIFER
- MFS - McNAIRY FLOW SYSTEM

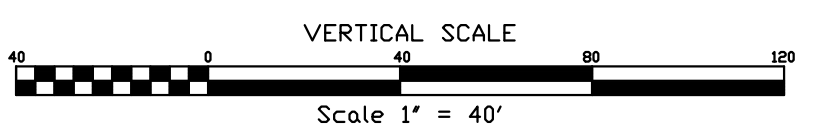
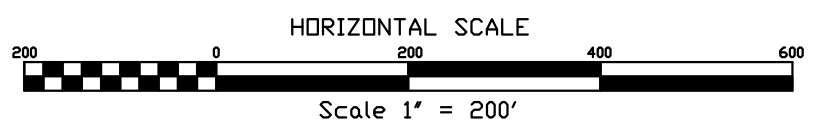

LATA Environmental Services of Kentucky, LLC  
 U.S. DEPARTMENT OF ENERGY  
 DOE PORTSMOUTH/PADUCAH PROJECT OFFICE  
 PADUCAH GASEOUS DIFFUSION PLANT

**Figure 1.8.**  
**Hydrogeologic Cross Section A-A' at SWMU 1**

FILE NAME: fig 1-8 PROJECT # 11105 SCALE: AS NOTED DATE: 1/4/2011

**B**  
NORTHWEST

**B'**  
NORTHEAST

ELEVATION  
(FT/AMSL)

ELEVATION  
(FT/AMSL)

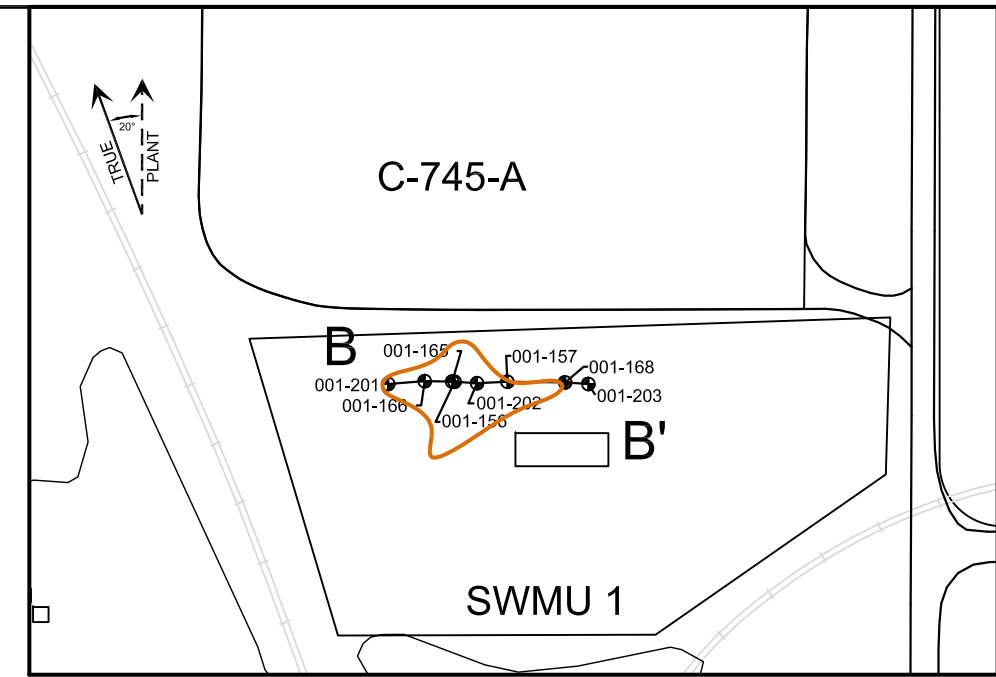
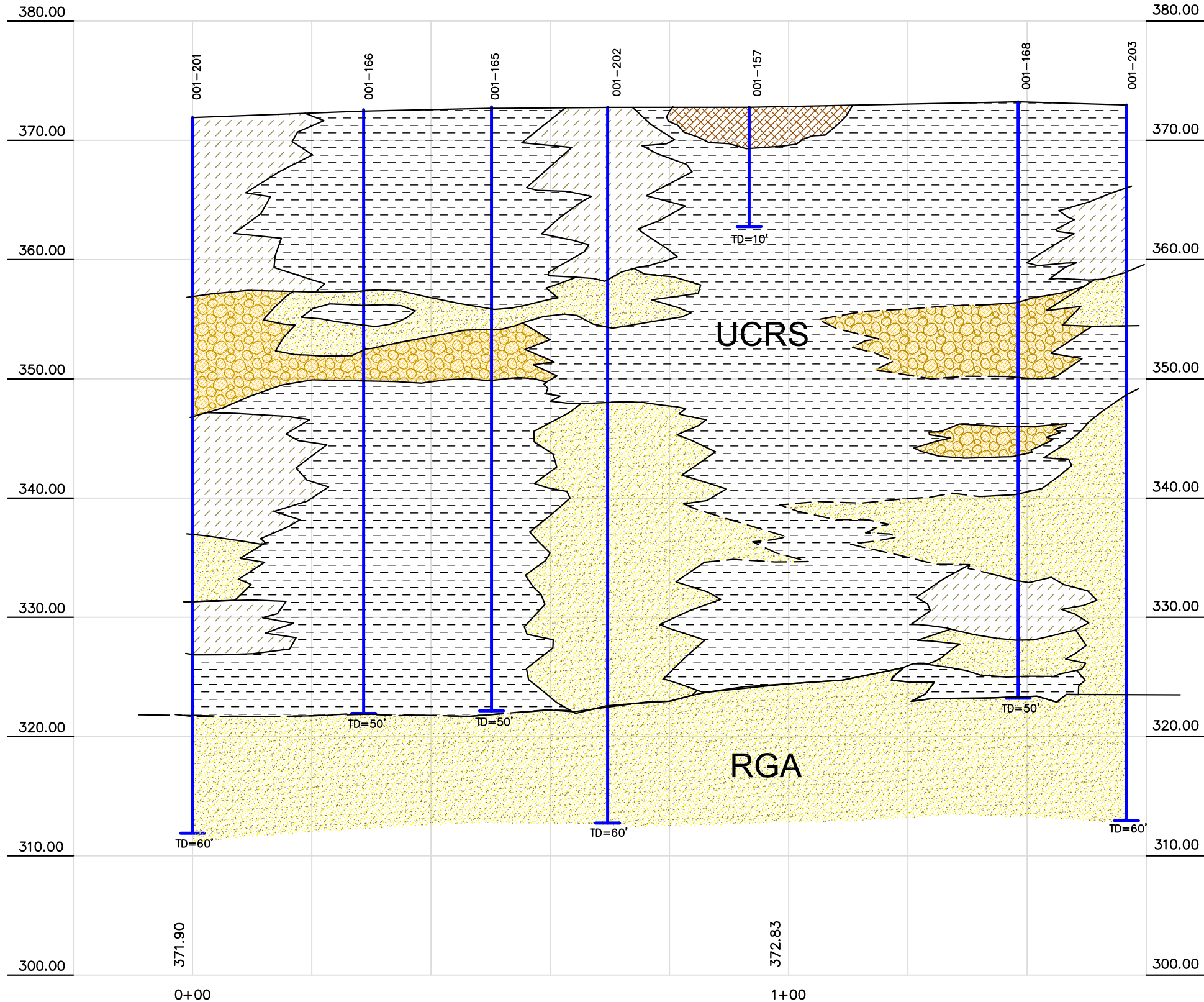

**LOCATION MAP**  
SCALE: 1" = 150'

**LEGEND**

- GRAVEL
- DASHED WHERE INFERRED
- CLAY
- SAND
- SILT
- FILL
- UCRS - UPPER CONTINENTAL RECHARGE SYSTEM
- RGA - REGIONAL GRAVEL AQUIFER

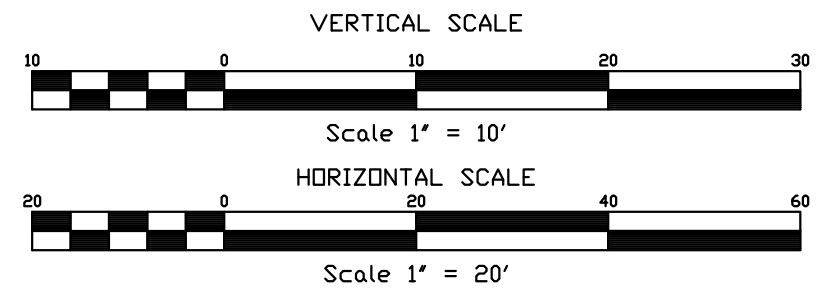

	U.S. DEPARTMENT OF ENERGY DOE PORTSMOUTH/PADUCAH PROJECT OFFICE PADUCAH GASEOUS DIFFUSION PLANT		
	<b>Figure 1.9.</b> Geologic Cross Section B-B' at SWMU 1		

**A**  
**NORTHWEST**

**A'**  
**SOUTHEAST**

ELEVATION  
(FT/AMSL)

ELEVATION  
(FT/AMSL)

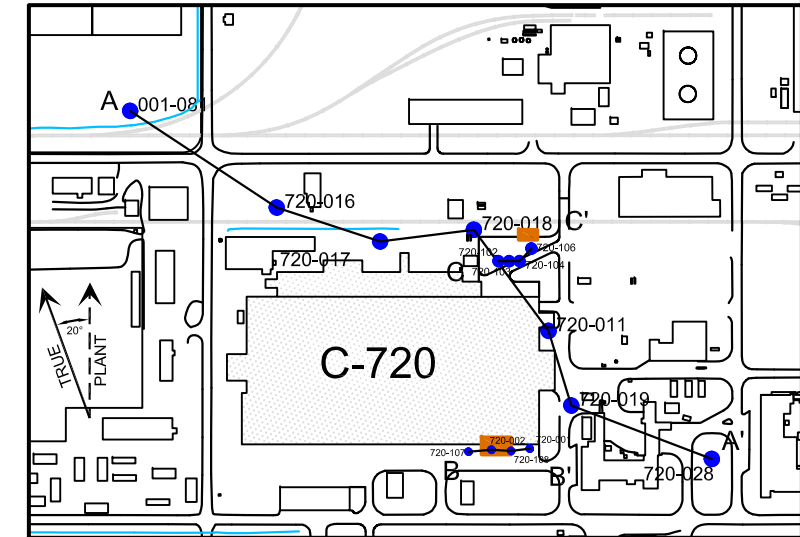
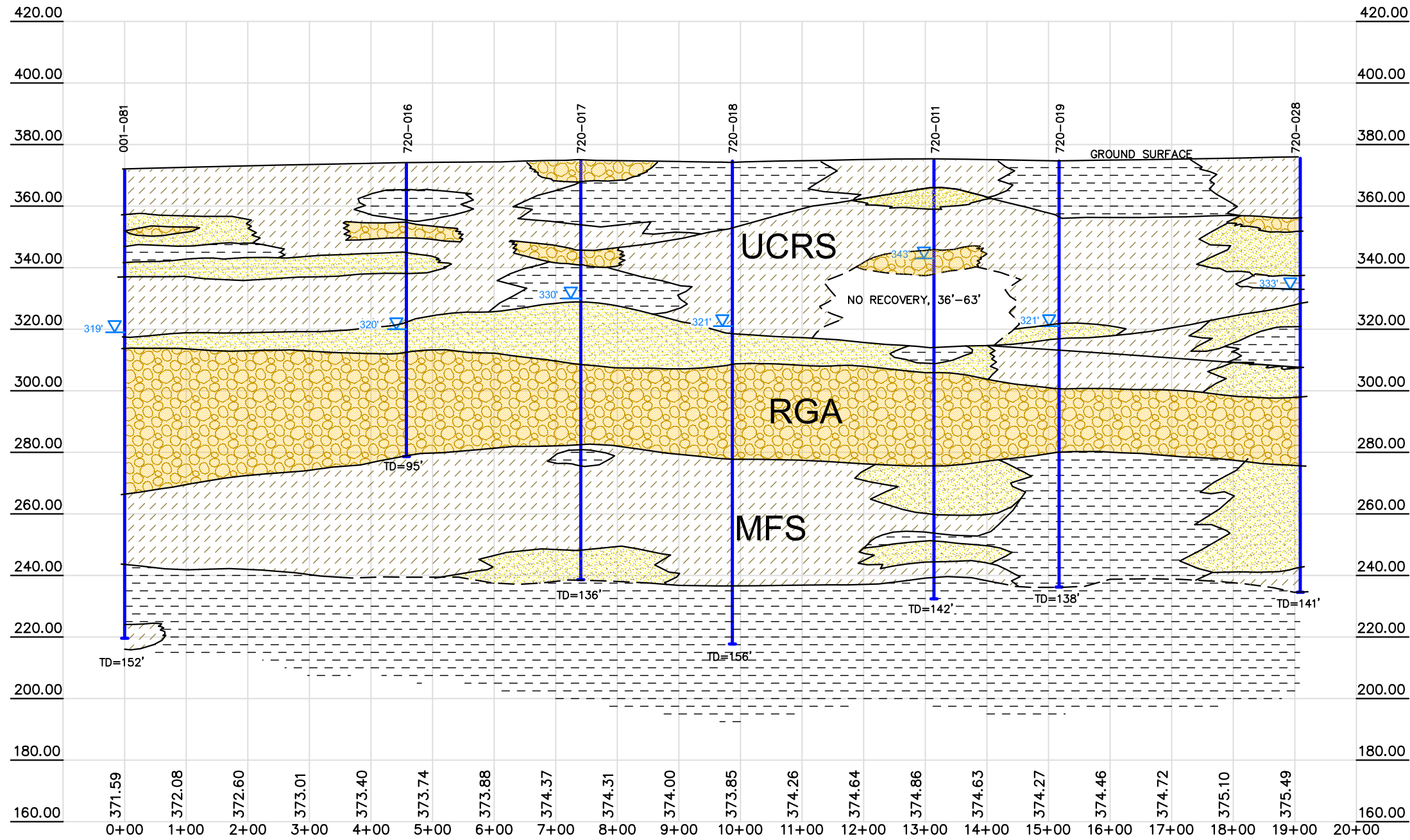

**LOCATION MAP**  
SCALE: 1" = 500'

**LEGEND**

- CLAY
- GRAVEL
- SAND
- SILT
- WATER LEVEL AT TIME OF GEOPHYSICAL LOG
- DASHED WHERE INFERRED
- UCRS - UPPER CONTINENTAL RECHARGE SYSTEM
- RGA - REGIONAL GRAVEL AQUIFER
- MFS - McNAIRY FLOW SYSTEM
- NO RECOVERY

NOTE: NO RECOVERY, LITHOLOGY INFERRED BASED ON DRILLING METHOD OR BORING RECORD NOTES.

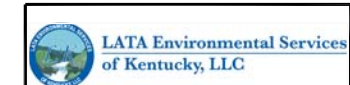
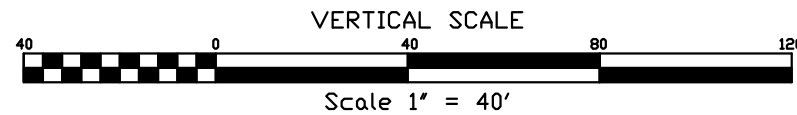
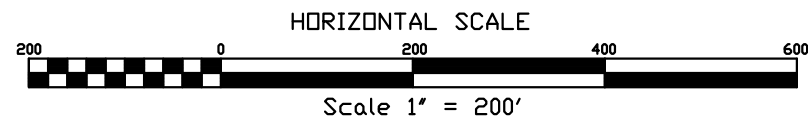

**U.S. DEPARTMENT OF ENERGY**  
**DOE PORTSMOUTH/PADUCAH PROJECT OFFICE**  
**PADUCAH GASEOUS DIFFUSION PLANT**

**Figure 1.10.**  
**Geologic Cross Section A-A' at the C-720 Complex**

FILE NAME: Fig 1-10	PROJECT #: 11105	SCALE: AS NOTED	DATE: 1/5/2011
---------------------	------------------	-----------------	----------------



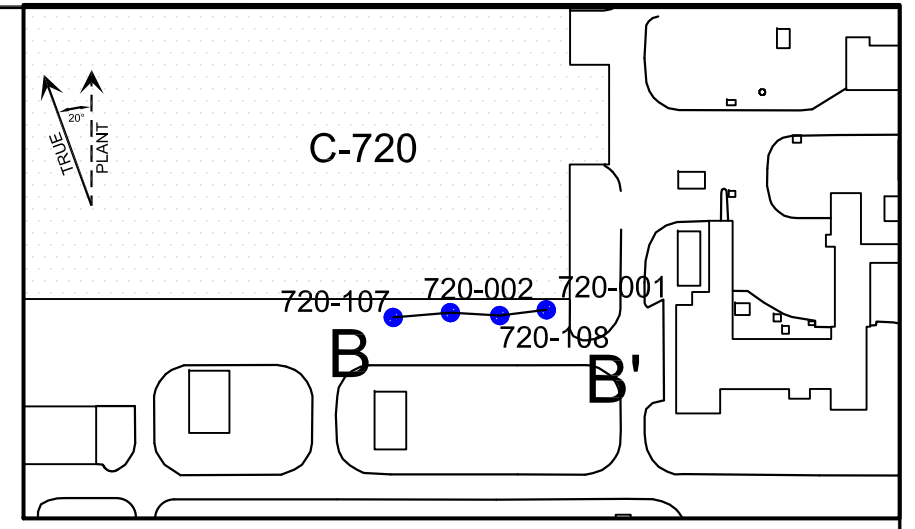
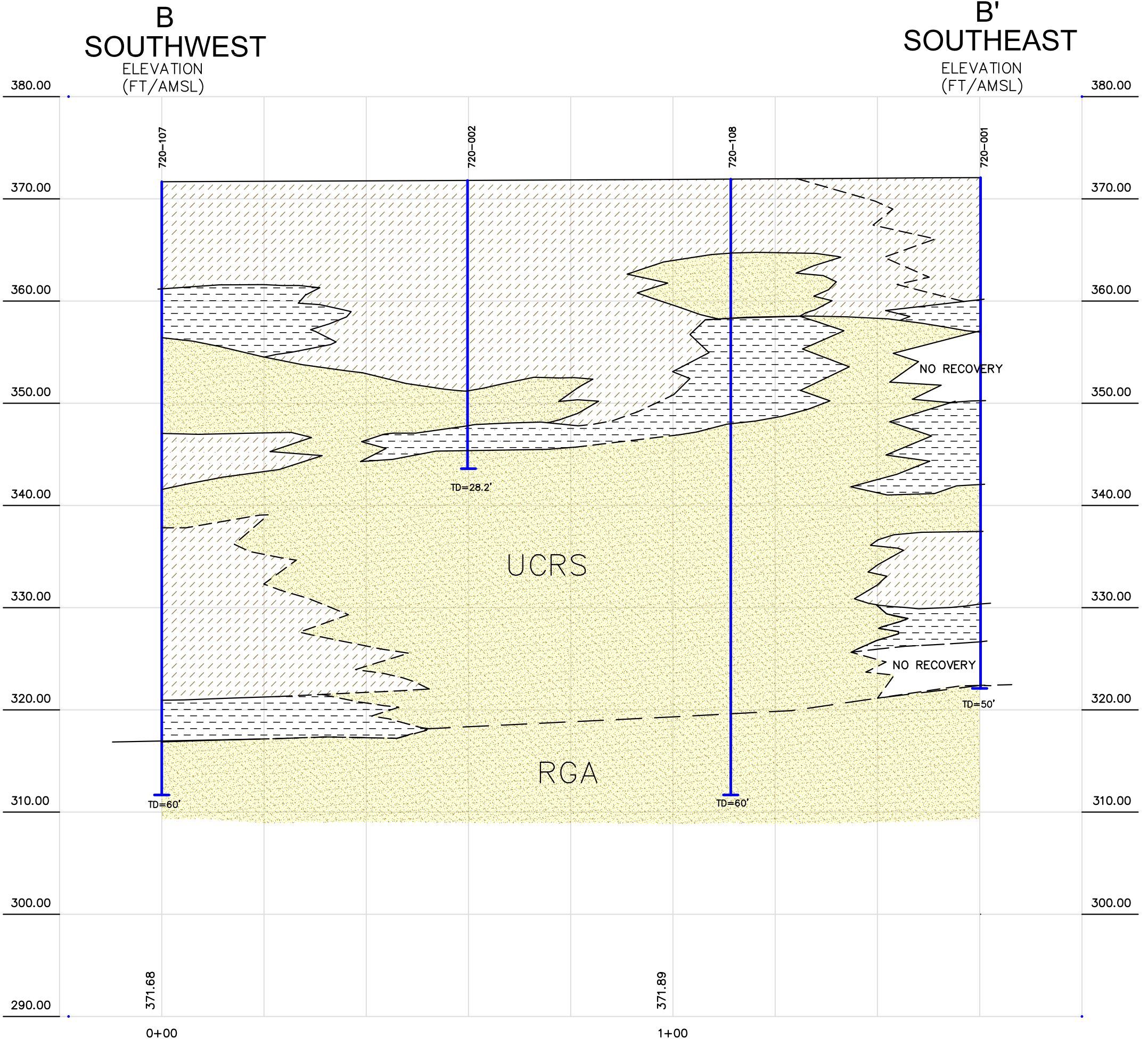

**LOCATION MAP**  
SCALE: 1" = 200'

**LEGEND**

- CLAY
  - SAND
  - SILT
  - NO RECOVERY
  - DASHED WHERE INFERRED
  - UCRS - UPPER CONTINENTAL RECHARGE SYSTEM
  - RGA - REGIONAL GRAVEL AQUIFER
- NOTE: NO RECOVERY, LITHOLOGY INFERRED BASED ON DRILLING METHOD OR BORING RECORD NOTES.

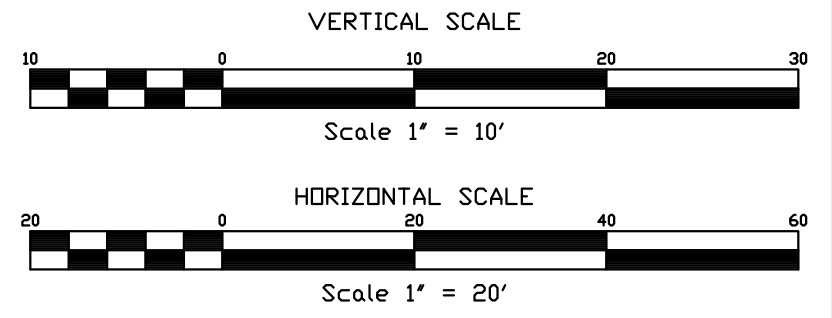

	<b>U.S. DEPARTMENT OF ENERGY</b> <b>DOE PORTSMOUTH/PADUCAH PROJECT OFFICE</b> <b>PADUCAH GASEOUS DIFFUSION PLANT</b>		
	<b>Figure 1.11.</b> <b>Geologic Cross Section B-B' at the C-720 Complex</b>		
FILE NAME: Fig 1-11	PROJECT #: 11105	SCALE: AS NOTED	DATE: 1/05/2011

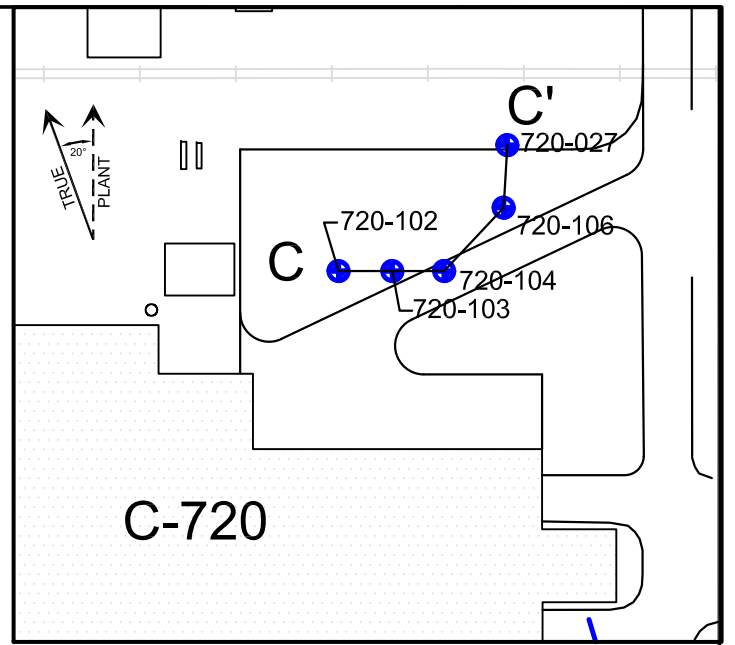
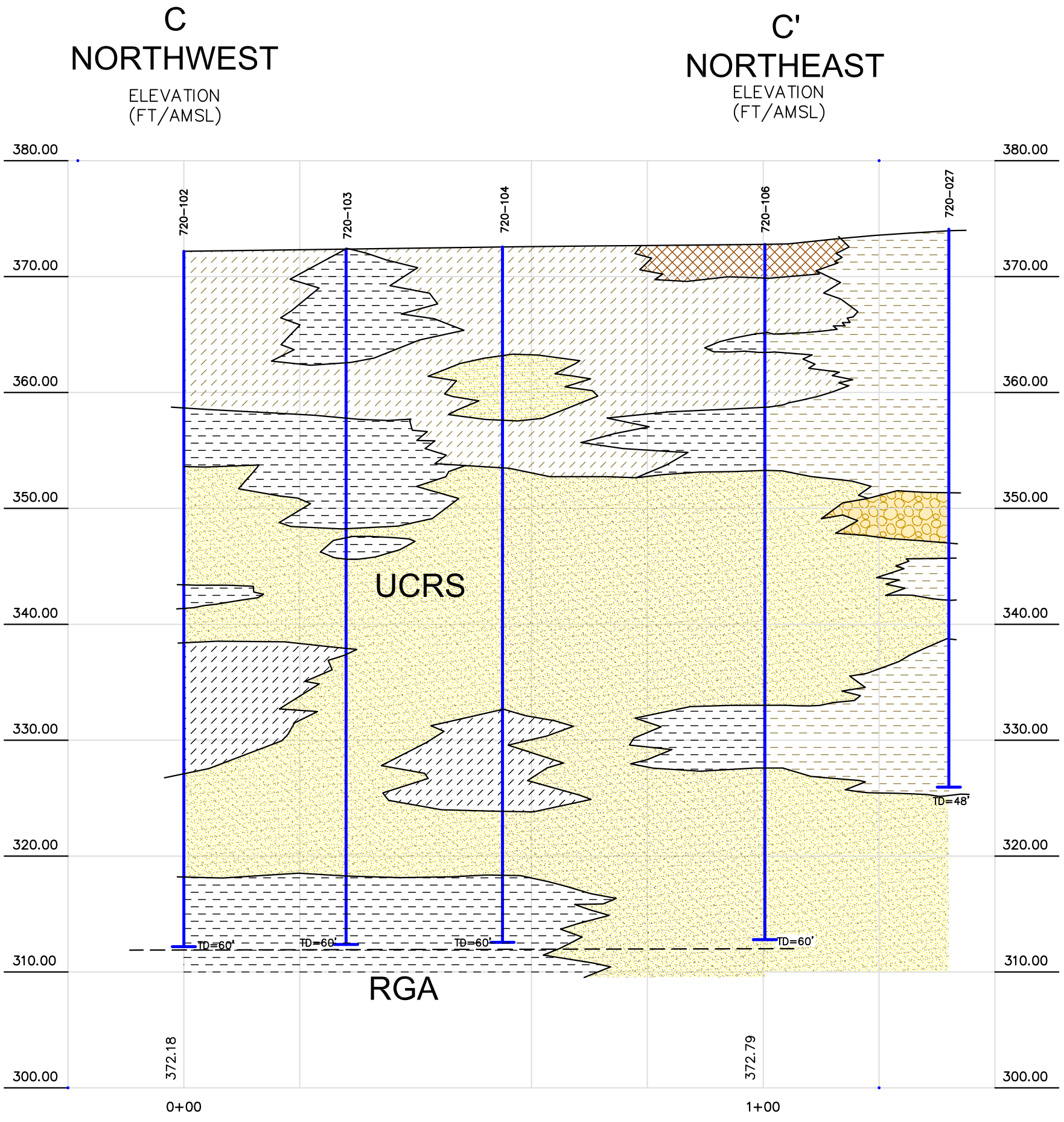

**LOCATION MAP**  
SCALE: 1" = 100'

**LEGEND**

- CLAY
- SAND
- SILT
- FILL
- GRAVEL

- UCRS - UPPER CONTINENTAL RECHARGE SYSTEM
- RGA - REGIONAL GRAVEL AQUIFER
- DASHED WHERE INFERRED

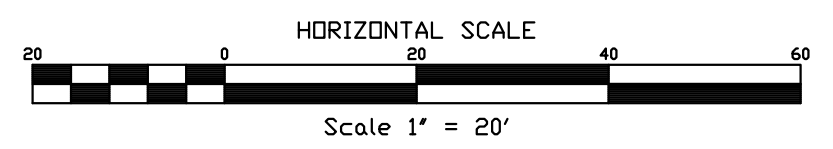
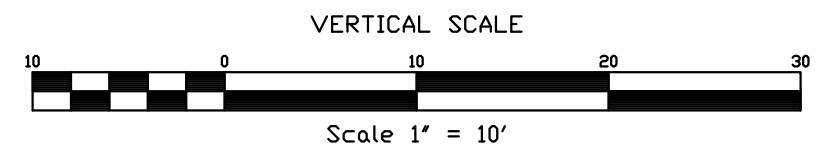

	U.S. DEPARTMENT OF ENERGY DOE PORTSMOUTH/PADUCAH PROJECT OFFICE PADUCAH GASEOUS DIFFUSION PLANT		
	<b>Figure 1.12.</b> <b>Geologic Cross Section C-C' at the C-720 Complex</b>		
FILE NAME: Fig 1-12	PROJECT #: 11105	SCALE: AS NOTED	DATE: 1/5/2011

**THIS PAGE INTENTIONALLY LEFT BLANK**

significant increase in moisture content, consistent with trends near the top of the RGA. At the Oil Landfarm, the depth to the water table in the UCRS averages approximately 4.26 m (14 ft), but can be as shallow as 2.13 m (7 ft) due to seasonal variability. Slug tests on UCRS MWs near the Oil Landfarm indicated a hydraulic conductivity of approximately 1.5E-05 in/s (3.9E-05 cm/s) (DOE 2007).

Soil sampling to a depth of 18.3 m (60 ft) was conducted at the C-720 Building Area. As in other soil borings in the C-720 Building Area, the soil textures are inconsistent with the typical HU2/HU3 contact where the top of the HU3 appears to consist predominately of silty sands. The RGA was not encountered. In the C-720 Building Area, the depth to water in the UCRS ranges from 1.83 to 13.7 m (6 to 45 ft) below surface with an average of 8.8 m (29 ft). The hydraulic conductivity of the UCRS near the C-720 Building is 1.34E-05 in/sec (3.4E-05 cm/s) (DOE 2007).

The Southwest Plume SI consisted of soil sampling to a depth of 6.1 m (20 ft) adjacent to the Storm Sewer. Because this was an area of construction, the majority of the soil encountered bgs probably was backfill material. The soils typically were silts, clays, and fine sands that were similar to the HU1 sediments (DOE 2007).

## **1.2.2 Contaminant History**

The Southwest Plume refers to an area of groundwater contamination at PGDP in the RGA that is south of the Northwest Groundwater Plume and west of the C-400 Building. The Southwest Plume was identified during the WAG 27 RI in 1998 (DOE 1999a). Additional work to characterize the plume (SWMU 210) was performed as part of the WAG 3 RI and Data Gaps Investigations, both in 1999. The Southwest Plume SI (DOE 2007) most recently evaluated potential source areas of contamination to the Southwest Plume (see Figure 1.4) and profiled the current level and distribution of VOCs in the plume along the west plant fence line. Confirmation of the nature and extent of contamination from the Southwest Plume SI is discussed in Section 1.2.3. Figure\_1.13 presents the extent of the TCE plume for the Southwest Plume, as it was understood in 2003, prior to the Southwest Plume SI. Figures 1.14 through 1.16 provide historical TCE data and the associated plume interpretation associated with the soil samples collected in the area of the cross-sections provided in Figures 1.9, 1.11 and 1.12. The history of each of the source areas is presented here.

### **1.2.2.1 C-747-C Oil Landfarm (SWMU 1)**

Between 1973 and 1979, the Oil Landfarm was used for landfarming of waste oils contaminated with TCE, uranium, polychlorinated biphenyls (PCBs), and 1,1,1-trichloroethane (TCA). These waste oils are believed to have been derived from a variety of PGDP processes. The landfarm consisted of two 104.5-m<sup>2</sup> (1,125-ft<sup>2</sup>) plots that were plowed to a depth of 0.305 to 0.61 m (1 to 2 ft). Waste oils were spread on the surface every 3 to 4 months, then the area was limed and fertilized.

### **1.2.2.2 C-720 Building Area (SWMUs 211A and 211B)**

The C-720 Building is located in the west-central area of the PGDP, southwest of the C-400 Building. The C-720 Building consists of several repair and machine shops, as well as other support operations. The WAG 27 RI identified areas of TCE contamination at the C-720 Building Area. This FFS addresses two areas that were identified in the Resolution. One area was underneath the parking lot and equipment storage area at the northeast corner of the building. The second area was located underneath the parking lot adjacent to the loading docks at the southeast corner of the building.

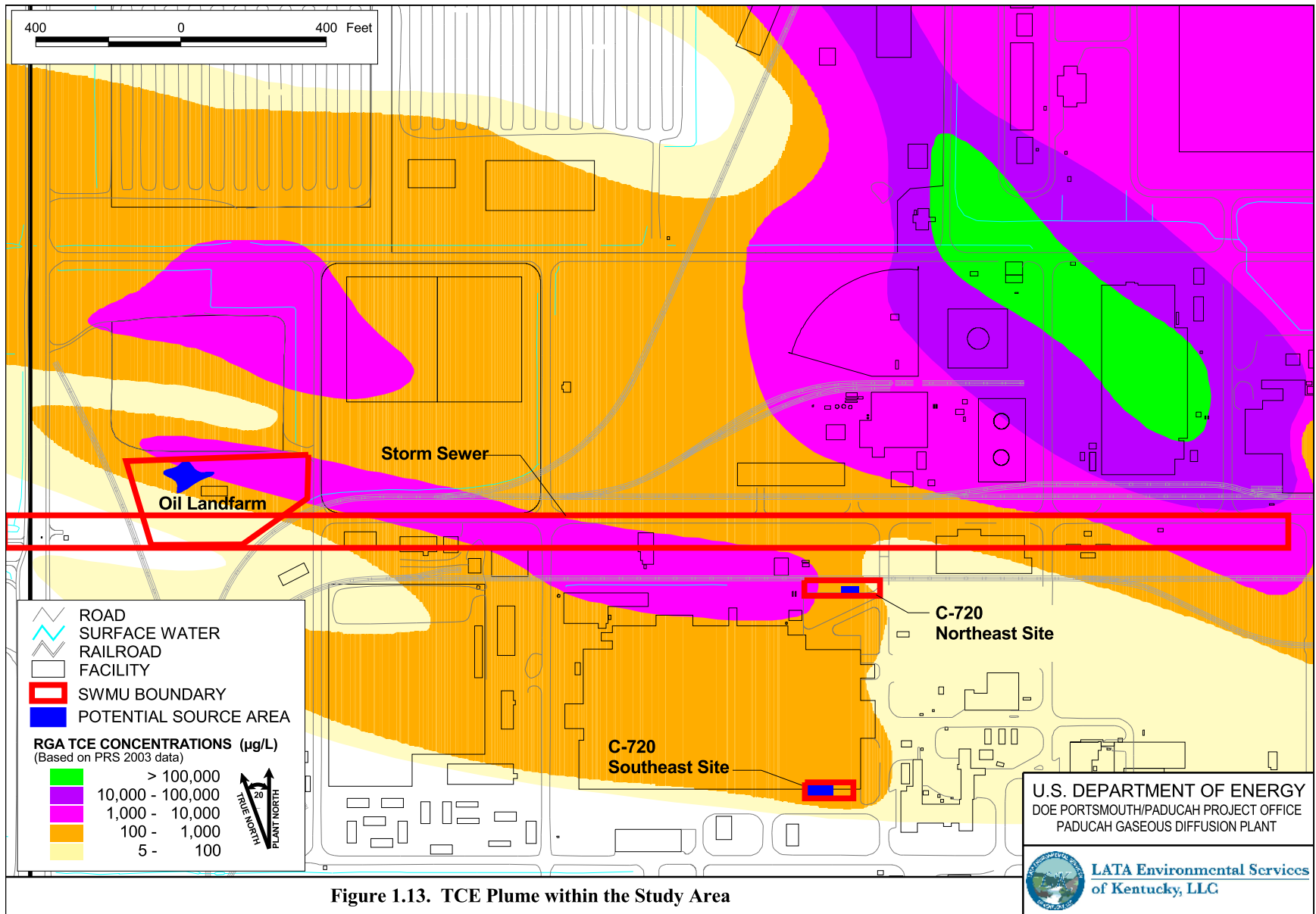
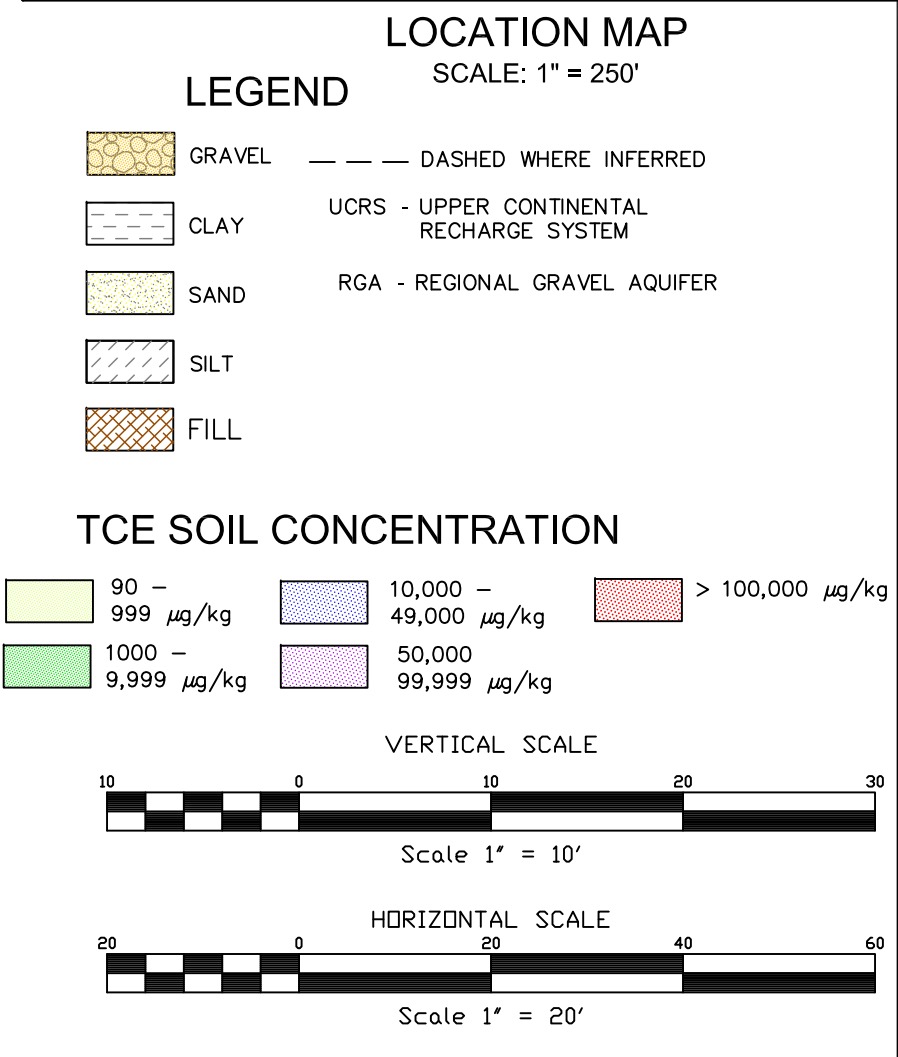
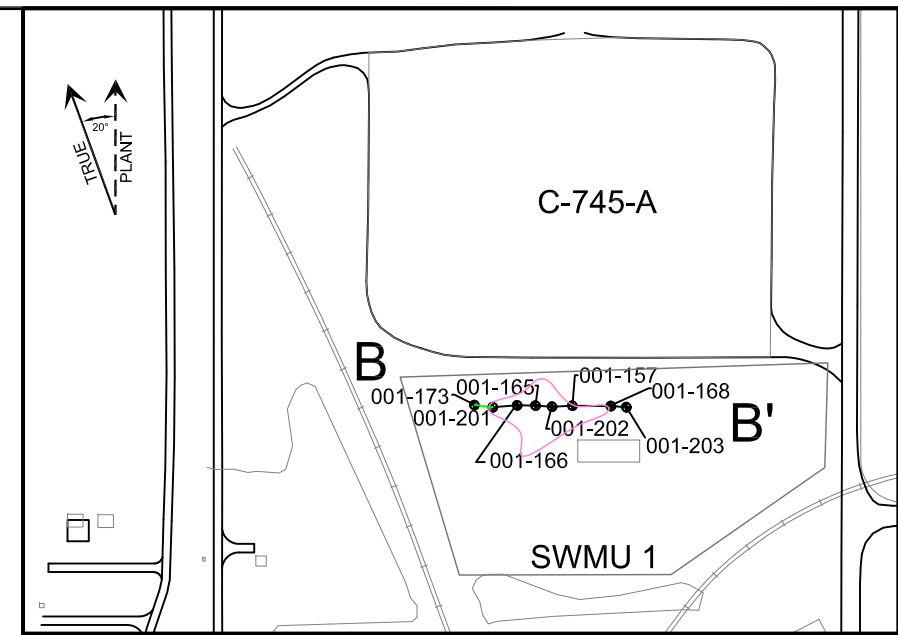
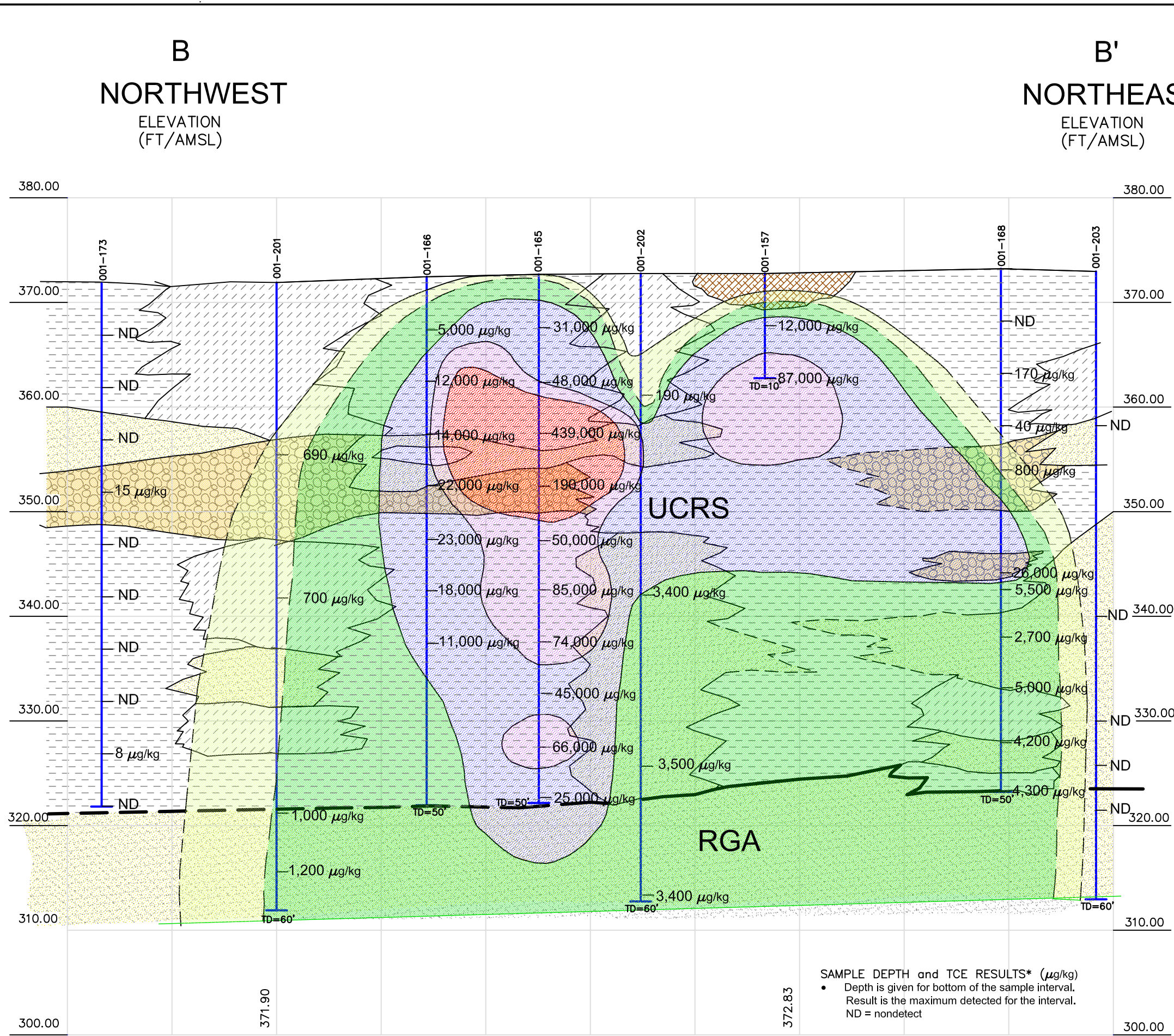

Figure 1.13. TCE Plume within the Study Area



SAMPLE DEPTH and TCE RESULTS\* ( $\mu\text{g}/\text{kg}$ )

- Depth is given for bottom of the sample interval. Result is the maximum detected for the interval. ND = nondetect

	U.S. DEPARTMENT OF ENERGY DOE PORTSMOUTH/PADUCAH PROJECT OFFICE PADUCAH GASEOUS DIFFUSION PLANT						
	<b>Figure 1.14.</b> <b>Geologic Cross Section B-B' at SWMU 1 with TCE Plume</b>						
FILE NAME:	Fig 1-14	PROJECT #:	11105	SCALE:	AS NOTED	DATE:	1/4/2011

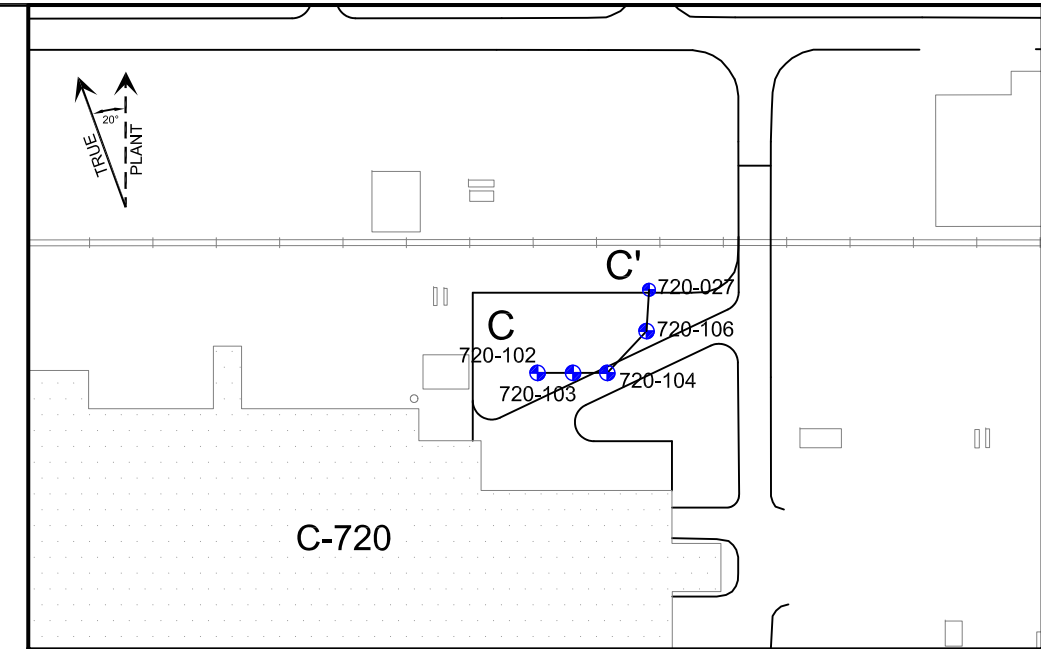
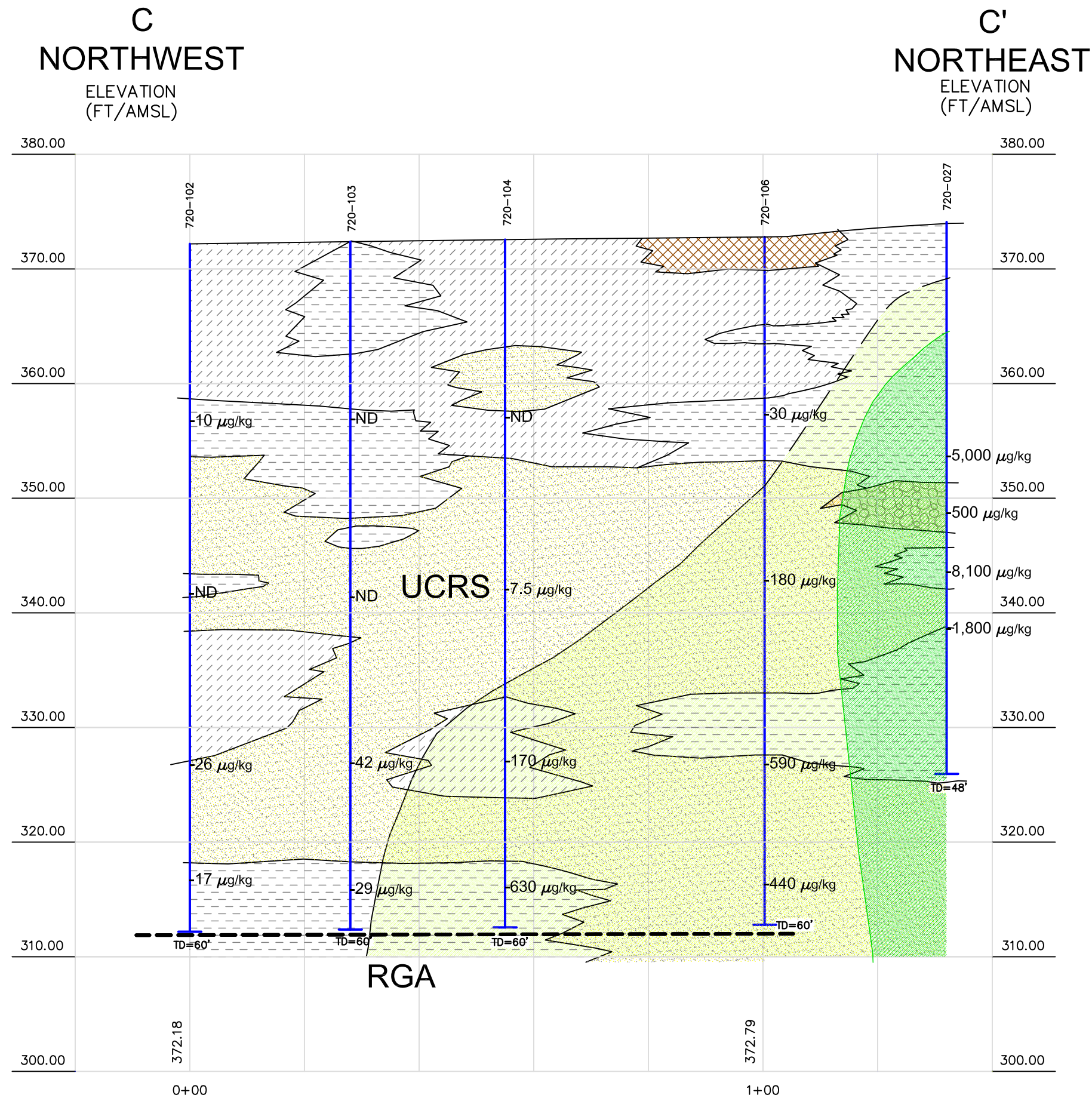

**LEGEND**

- CLAY
- SAND
- SILT
- FILL
- GRAVEL
- UCRS - UPPER CONTINENTAL RECHARGE SYSTEM
- RGA - REGIONAL GRAVEL AQUIFER

**TCE SOIL CONCENTRATION**

- 90 - 999  $\mu\text{g}/\text{kg}$
- 1000 - 9,999  $\mu\text{g}/\text{kg}$
- 10,000 - 49,000  $\mu\text{g}/\text{kg}$
- 50,000 - 99,999  $\mu\text{g}/\text{kg}$
- > 100,000  $\mu\text{g}/\text{kg}$

**VERTICAL SCALE**

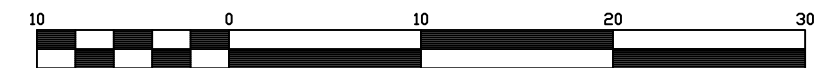

Scale 1" = 10'

**HORIZONTAL SCALE**

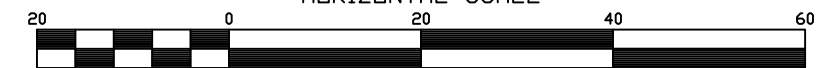

Scale 1" = 20'

	U.S. DEPARTMENT OF ENERGY DOE PORTSMOUTH/PADUCAH PROJECT OFFICE PADUCAH GASEOUS DIFFUSION PLANT		
	<b>Figure 1.15.</b> <b>Geologic Cross Section C-C' at the C-720 Complex with TCE Plume</b>		
FILE NAME:	PROJECT #:	SCALE:	DATE:
Fig 1-15	11105	AS NOTED	1/6/2011

**B**  
SOUTHWEST  
ELEVATION  
(FT/AMSL)

**B'**  
SOUTHEAST  
ELEVATION  
(FT/AMSL)

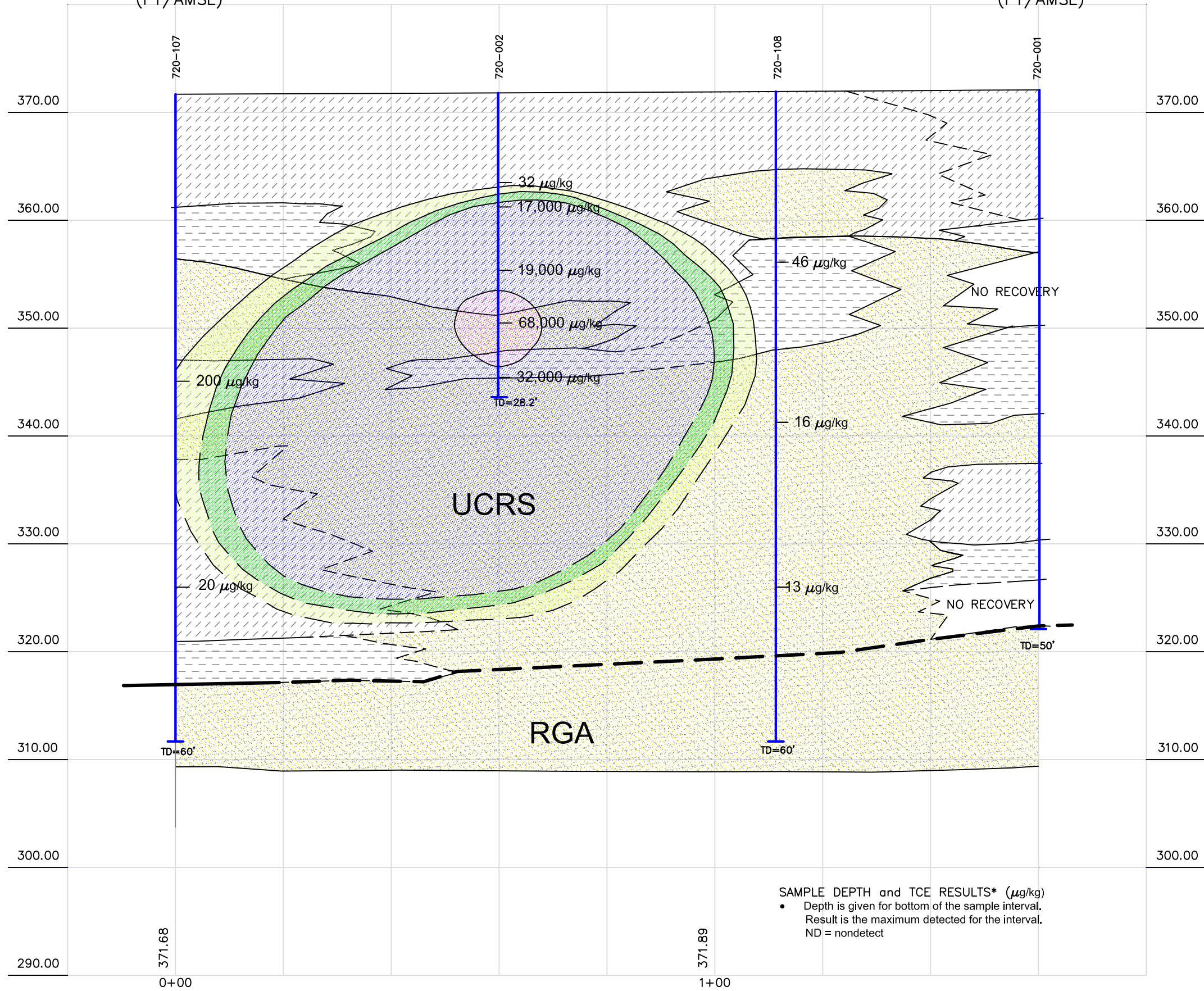

SAMPLE DEPTH and TCE RESULTS\* (µg/kg)  
 • Depth is given for bottom of the sample interval.  
 Result is the maximum detected for the interval.  
 ND = nondetect

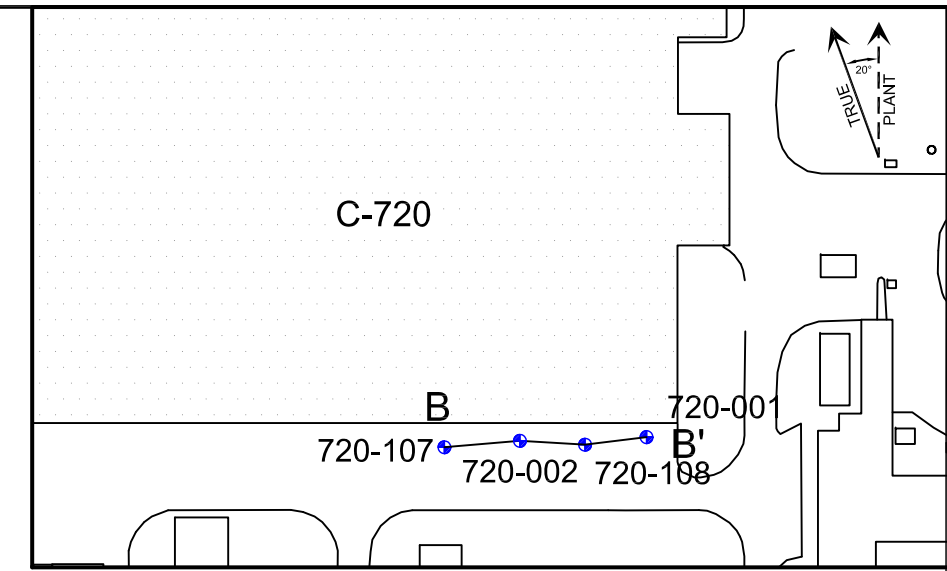

**LOCATION MAP**  
SCALE: 1" = 150'

**LEGEND**

- CLAY
- SAND
- NO RECOVERY
- SILT
- DASHED WHERE INFERRED
- UCRS - UPPER CONTINENTAL RECHARGE SYSTEM
- RGA - REGIONAL GRAVEL AQUIFER

NOTE: NO RECOVERY, LITHOLOGY INFERRED BASED ON DRILLING METHOD OR BORING RECORD NOTES.

**TCE SOIL CONCENTRATION**

- 90 - 999 µg/kg
- 10,000 - 49,000 µg/kg
- > 100,000 µg/kg symbol"/> > 100,000 µg/kg
- 1000 - 9,999 µg/kg
- 50,000 - 99,999 µg/kg

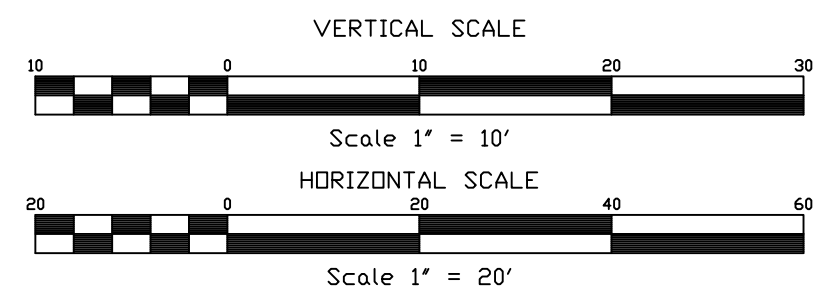

U.S. DEPARTMENT OF ENERGY  
DOE PORTSMOUTH/PADUCAH PROJECT OFFICE  
PADUCAH GASEOUS DIFFUSION PLANT

**Figure 1.16.**  
**Geologic Cross Section B-B' at the C-720 Complex with TCE Plume**



**THIS PAGE INTENTIONALLY LEFT BLANK**

**C-720 Northeast Site (SWMU 211A).** Contamination found to the northeast of the C-720 Building is believed to have been released during routine equipment cleaning and rinsing performed in the area. Solvents were used to clean parts, and the excess solvent may have been discharged on the ground. Spills and leaks from the cleaning process also may have contaminated surface soils in the area. Solvents may have migrated as dissolved contamination, as rainfall percolating through the soils and migrating to deeper soils and the shallow groundwater, or as DNAPL migrating to adjacent and underlying soils.

**C-720 Southeast Site (SWMU 211B).** The source of VOC contamination found southeast of the C-720 Building is not certain. The VOCs found in this area may have originated from spills that occurred within the building, with subsequent discharge to storm drains leading to the southeast corner of the building or from spills or leaks on the loading dock or parking lot located to the southeast of the building. The area of concern discovered during the WAG 27 RI is near the outlet to one of the storm drains for the east end of the building. A storm sewer inlet for the southeast parking lot also is located in the vicinity. The north edge of the parking lot, where the contamination occurs, is the location of one of the loading docks for the C-720 Building, an area where chemicals, including solvents, may have been loaded or unloaded.

### 1.2.2.3 C-747 Plant Storm Sewer (SWMU 102)

During the WAG 6 RI, VOC contamination of subsurface soils was identified near two of the lateral lines that feed into the main storm sewer that runs south of the C-400 Building to Outfall 008 on the west side of PGDP. At one time, the eastern lateral appears to have been connected to the TCE degreaser sump inside the C-400 Building. The TCE that leaked from the sump/storm sewer connection to the surrounding soils had been identified as a potential source of groundwater contamination. There was a possibility that TCE was transported down the lateral to the main storm sewer line running to Outfall 008, encountered an undetermined breach in the storm sewer, and leaked to the surrounding soils to become a source of TCE to the Southwest Plume.

The C-400 Building to Outfall 008 storm sewer drains the central west portion of the plant. Major areas and buildings that contribute storm water runoff to the system include all of the following:

- C-631 Cooling Towers
- C-331 Process Building (roof drains for northwest quadrant)
- C-310 Building (roof drains for north half)
- C-410/C-420 Complex
- C-400 Building
- C-409 Building
- C-600 Steam Plant area
- C-720 Building (roof drains for north and west sides and associated shops on north side)
- C-746-H3 Storage Pad
- C-740 Storage Yard

Construction drawings show that the Outfall 008 storm sewer begins to the east of the C-400 Building as a 15-inch-diameter pipe. The video survey of the Outfall 008 storm sewer that was part of the Southwest Plume SI revealed that the main storm sewer south of the C-400 Building is a 91.44-cm-diameter (36-inch-diameter), reinforced-concrete pipe that enlarges to a 121.9-cm-diameter (48-inch-diameter) pipe and then a 137.16-cm-diameter (54-inch-diameter) pipe between 10<sup>th</sup> and 8<sup>th</sup> Streets. West of 8<sup>th</sup> Street, the Outfall 008 storm sewer continues as a 182.9-cm-diameter (72-inch-diameter) pipe. The video survey confirmed that the bottom of the storm sewer is between 3.96 to 4.6 m (13 and 15 ft) bgs. Construction drawings indicate that the feeder lines into the main storm sewer range from 8-inch-diameter vitreous clay pipe to 60.96-cm-diameter (24-inch-diameter) concrete pipe.

#### **1.2.2.4 C-747 Contaminated Burial Yard (SWMU 4)**

The C-747 Contaminated Burial Yard operated from 1951 through 1958 and was used for disposal of contaminated and uncontaminated trash, some of which was burned. Waste materials from the C-400 Building, originally designated for the C-404 Burial Area, may have been placed at SWMU 4 as well. Scrapped equipment with surface contamination from the enrichment process also was buried. The site consists of several pits excavated to about 15 ft. The waste was placed in the pits and was covered with 2 to 3 ft of soil. A 6-inch clay cap was installed in 1982 (DOE 2007).

The site was investigated during the Phase II SI and the WAG 3 RI. The COCs identified in these reports include radionuclides, heavy metals, solvents, semivolatile organics, and PCBs. The Southwest Plume SI focused on the RGA groundwater east and west of the unit and did not evaluate the fate and transport or risk contributions from those COCs. The Burial Grounds OU RI will evaluate these areas further (DOE 2007).

#### **1.2.2.5 Previous investigations**

Investigations of the Southwest Plume and potential source areas are documented in the following reports.

- *Results of the Site Investigation, Phase I, at the Paducah Gaseous Diffusion Plant, Paducah, Kentucky* (CH2M HILL 1991).
- *Results of the Site Investigation, Phase II, at the Paducah Gaseous Diffusion Plant, Paducah, Kentucky* (CH2M HILL 1992).
- *Final Remedial Action Report for Waste Area Grouping (WAG) 23 and Solid Waste Management Unit 1 of WAG 27 at the Paducah Gaseous Diffusion Plant, Paducah, Kentucky* (DOE 1998a).
- *Remedial Investigation Report for Waste Area Grouping 27 at the Paducah Gaseous Diffusion Plant, Paducah, Kentucky* (DOE 1999a).
- *Remedial Investigation Report for Waste Area Grouping 6 at the Paducah Gaseous Diffusion Plant, Paducah, Kentucky* (DOE 1999b).
- *Remedial Investigation Report for Waste Area Grouping 3 at the Paducah Gaseous Diffusion Plant, Paducah, Kentucky* (DOE 2000a).
- *Data Report for the Sitewide Remedial Evaluation for Source Areas Contributing to Off-Site Groundwater Contamination at the Paducah Gaseous Diffusion Plant, Paducah, Kentucky* (also known as Data Gaps Document) (DOE 2000b).
- *Feasibility Study for the Groundwater Operable Unit at the Paducah Gaseous Diffusion Plant, Paducah, Kentucky* (DOE 2001b).
- *Site Investigation Report for the Southwest Groundwater Plume at the Paducah Gaseous Diffusion Plant, Paducah, Kentucky* (DOE 2007).
- *Focused Feasibility Study for the Southwest Groundwater Plume Volatile Organic Compound Sources (Oil Landfarm and C-720 Northeast and Southeast Sites) at the Paducah Gaseous Diffusion Plant, Paducah, Kentucky* (DOE 2010a).

### **1.2.2.6 Southwest Plume SI**

The Oil Landfarm, C-720 Building Area, and Storm Sewer most recently were investigated in the Southwest Plume SI. The objectives of the Southwest Plume SI were to collect sufficient data to do the following:

- Determine which units are sources of contamination to the Southwest Plume;
- Determine which units are not sources of contamination to the Southwest Plume;
- Fill data gaps for risk assessment of the identified source areas; and
- Reduce uncertainties and increase the understanding of the Southwest Plume and potential sources so that appropriate response actions can be identified, as necessary.

Data collection activities were designed to answer the principal study questions that were developed for each potential source area in the SI Work Plan (DOE 2004). At the Oil Landfarm, the C-720 Building Area, and along the Storm Sewer, VOC contamination in the shallow soils of the UCD were profiled using direct-push technology (DPT) combined with a membrane interface probe (MIP). Discrete-depth soil samples were collected to approximately 18.3 m (60 ft) bgs at the Oil Landfarm and the C-720 Building Area and 6.1 m (20 ft) bgs along the Storm Sewer. These samples were sent to laboratories for analyses of VOCs (for all sites), metals, and radionuclides (only for samples from the C-720 Building Area and from along the Storm Sewer).

Groundwater samples during the Southwest Plume SI were collected at various depths within the RGA using dual-wall reverse circulation drilling equipment at the Southwest Plume (SWMU 210). At the C-720 Building Area, groundwater samples were collected from the well cluster MW203 (RGA) and MW204 (UCRS). The principal study questions of the Southwest Plume SI did not require additional groundwater sampling to address the Oil Landfarm. Moreover, groundwater samples were not required to address the principal study questions for the Storm Sewer.

Table 1.2 illustrates the investigations completed in the Southwest Plume area and potential source area to which each applies.

### **1.2.3 Nature and Extent of Contamination**

This section illustrates and interprets the nature and extent of contamination for each study area. Potential source areas, as determined by the analytical results from field activities, are examined, and potential site-related contaminants are identified. Conceptual site models (CSMs) for the Southwest Plume sources are presented and discussed. Evaluations in this section are based on data collected in the Southwest Plume SI and results from previous investigations.

The historical data of operational events that provide an explanation for the presence of contamination at each of the study areas is described in Section 1.2.2, Site History. The degree to which these events impacted the surrounding areas was determined by the analytical results of the samples collected. In some cases, the close proximity of the study areas made isolating the original source of contamination difficult.

#### **1.2.3.1 Conceptual site model and site conditions**

The CSM for the Southwest Plume sites is presented in this section. The discussion of contaminant sources, release mechanisms, and transport pathways provides a basis for developing the RAOs and for

**Table 1.2. Summary of Investigations and Areas Investigated**

Date	Title	Southwest Plume	Oil Landfarm	C-720 Building Area	Storm Sewer	SWMU 4*
1989–1990	Phase I SI		✓		✓	
1990–1991	Phase II SI		✓	✓	✓	
March 1996	Site-specific sampling		✓			
1997	WAG 6 Remedial Investigation				✓	
1998	WAG 23 Removal Action		✓			
1998	WAG 27 Remedial Investigation	✓	✓	✓		
1999	Sitewide Data Gaps Investigation	✓				
1999	WAG 3 Remedial Investigation	✓				✓
2001	Groundwater OU Feasibility Study	✓	✓	✓	✓	
2007	Southwest Plume Site Investigation	✓	✓	✓	✓	✓

\*SWMU 4 is a component of the Burial Ground Operable Unit and will be remediated as necessary under that OU.

OU = operable unit

SI = site investigation

WAG = waste area grouping

SWMU = solid waste management unit

identifying and screening technologies and developing and analyzing alternatives. The CSM describes site conditions including nature and extent of contamination, contaminant fate and transport, and potential receptors. The CSM is described herein narratively and in the next three figures. The narrative CSM is comprised primarily of information summarized from the WAG 27 RI (DOE 1999a) and the SI Report (DOE 2007). The pictorial conceptual models, provided in Figures 1.17 and 1.18 for the Oil Landfarm and the C-720 Building Area, respectively, summarize the description, show surface and subsurface conditions, and aid in visualizing the narrative information. A pictorial CSM for the Storm Sewer is not provided. As discussed here, results of a video survey and sampling conducted during the Southwest Plume SI confirmed that the Storm Sewer was not a source of contamination to the Southwest Plume; therefore, the Storm Sewer is not carried forward in this FFS for alternative evaluation. The diagrammatic CSM detailing sources, receptors, and exposure pathways for both the Oil Landfarm and the C-720 Building area is shown in Figure 1.19.

**Oil Landfarm CSM.** The conceptual model of subsurface contamination for the Oil Landfarm consists of a discrete zone of soils with potential TCE DNAPL ganglia below the plow plots that extends from near the surface to the top of the RGA [approximately 16.76 m (55 ft) bgs]. The area of this contamination is estimated to be approximately 809 m<sup>2</sup> (8,700 ft<sup>2</sup> or 0.2 acre). Ganglia of potential TCE DNAPL may continue to leach TCE to the UCRS groundwater. Although there have been infrequent historical detections of dissolved TCE levels within some of the source zones exceeding 10,000 µg/L (which is consistent with the presence of free-phase TCE in ganglia),<sup>1</sup> no dissolved-phase concentrations greater than 10,000 µg/L have been detected in the UCRS or RGA water in the area of the Oil Landfarm for more than 10 years. Shallow groundwater flow is dominantly vertical in the Oil Landfarm area. The C-745-A Cylinder Yard located north and adjacent to SWMU 1 contains 10 ton cylinders of depleted uranium hexafluoride, which are not sources of VOCs or other groundwater contaminants.

<sup>1</sup>With the exception of the single highest value of TCE contamination reported in soil at SWMU 1 (400,000 µg/kg), the TCE-in-soil levels are easily accounted for by dissolved-phase contamination derived from a small DNAPL source zone. For further information, the reader is referred to *Feasibility Study for the Groundwater Operable Unit at Paducah Gaseous Diffusion Plant Paducah, Kentucky*, DOE/OR/07-1857&D2, Volume 4, Appendix C5 (DOE 2001b).

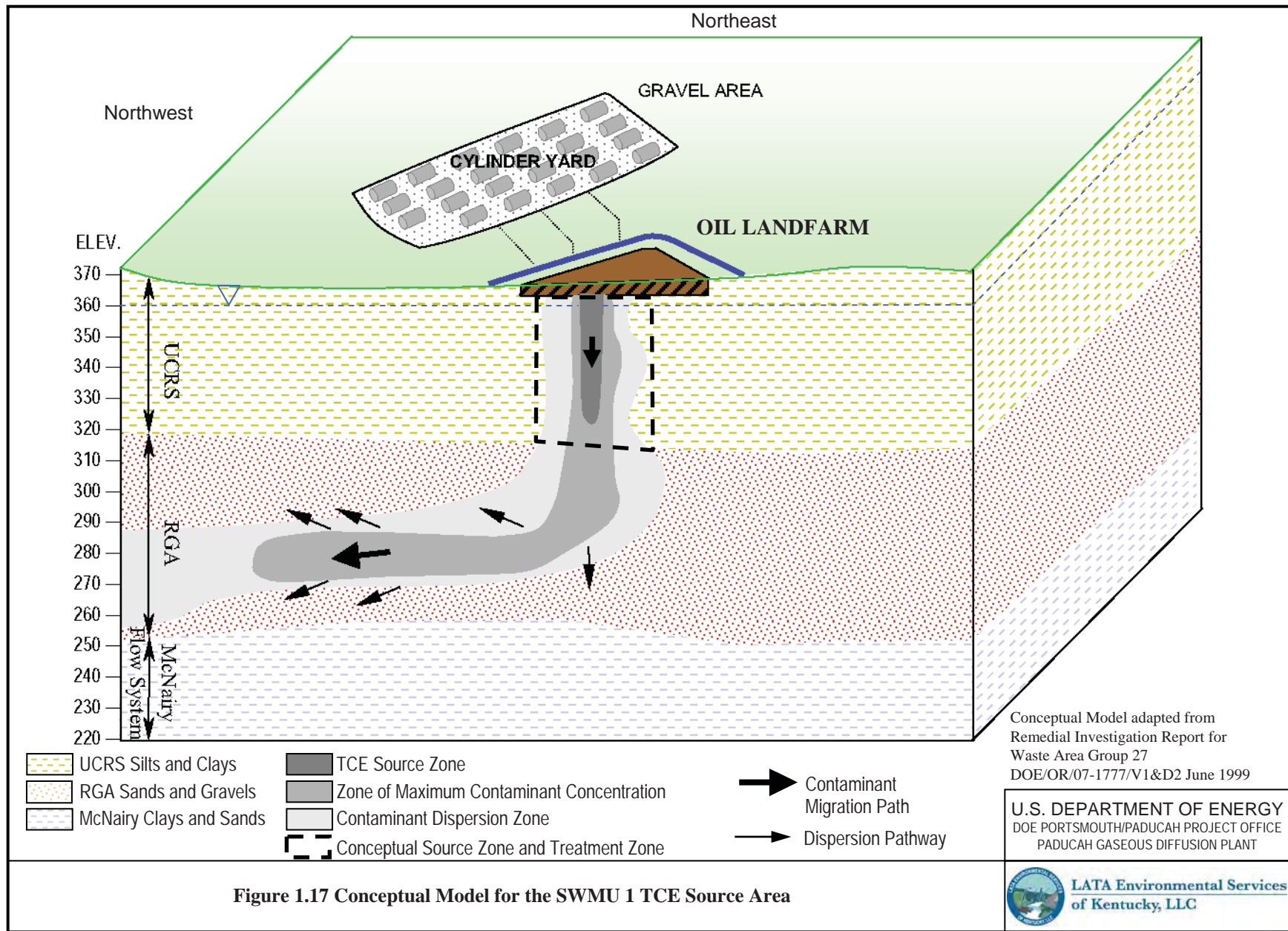

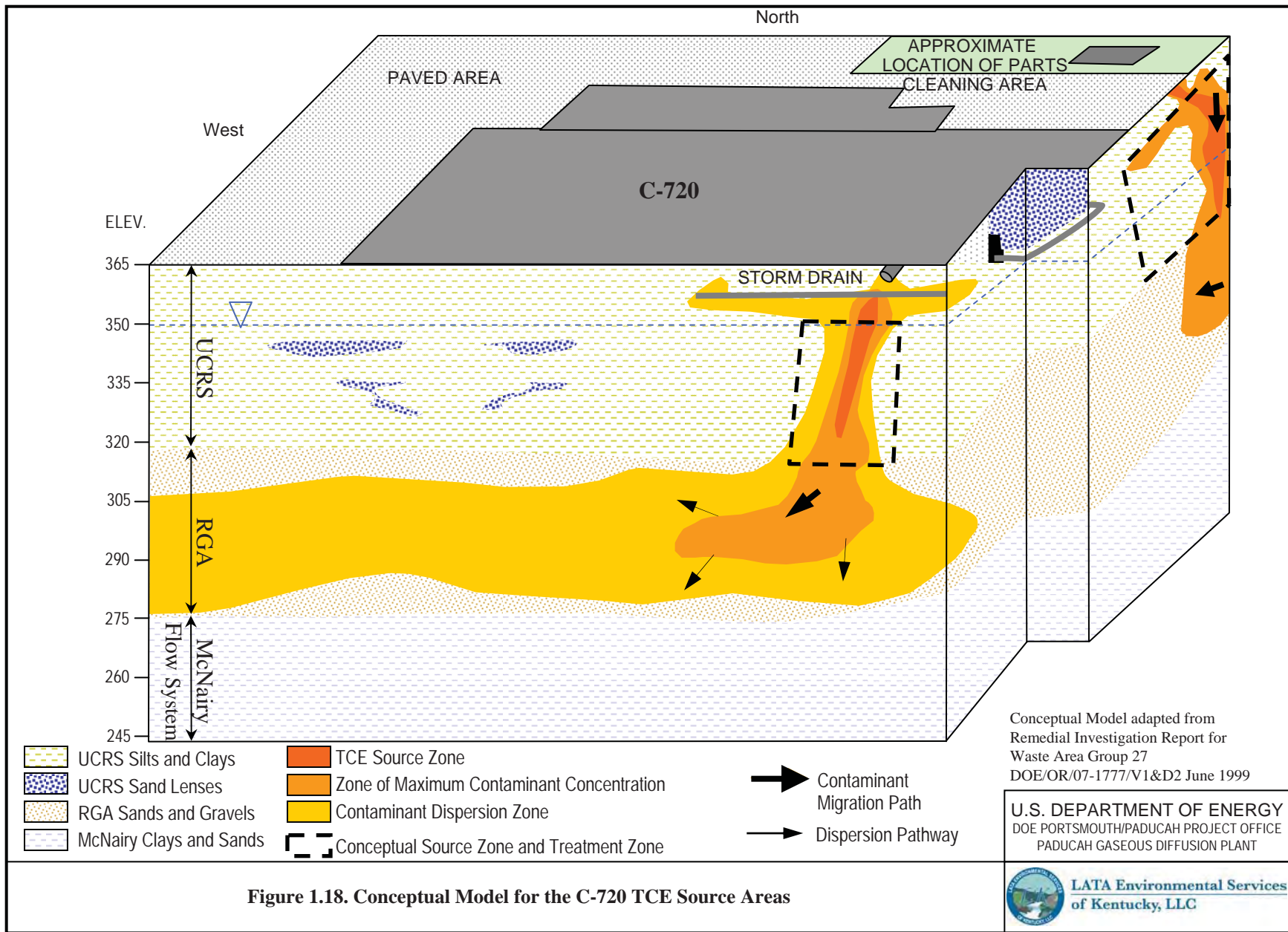
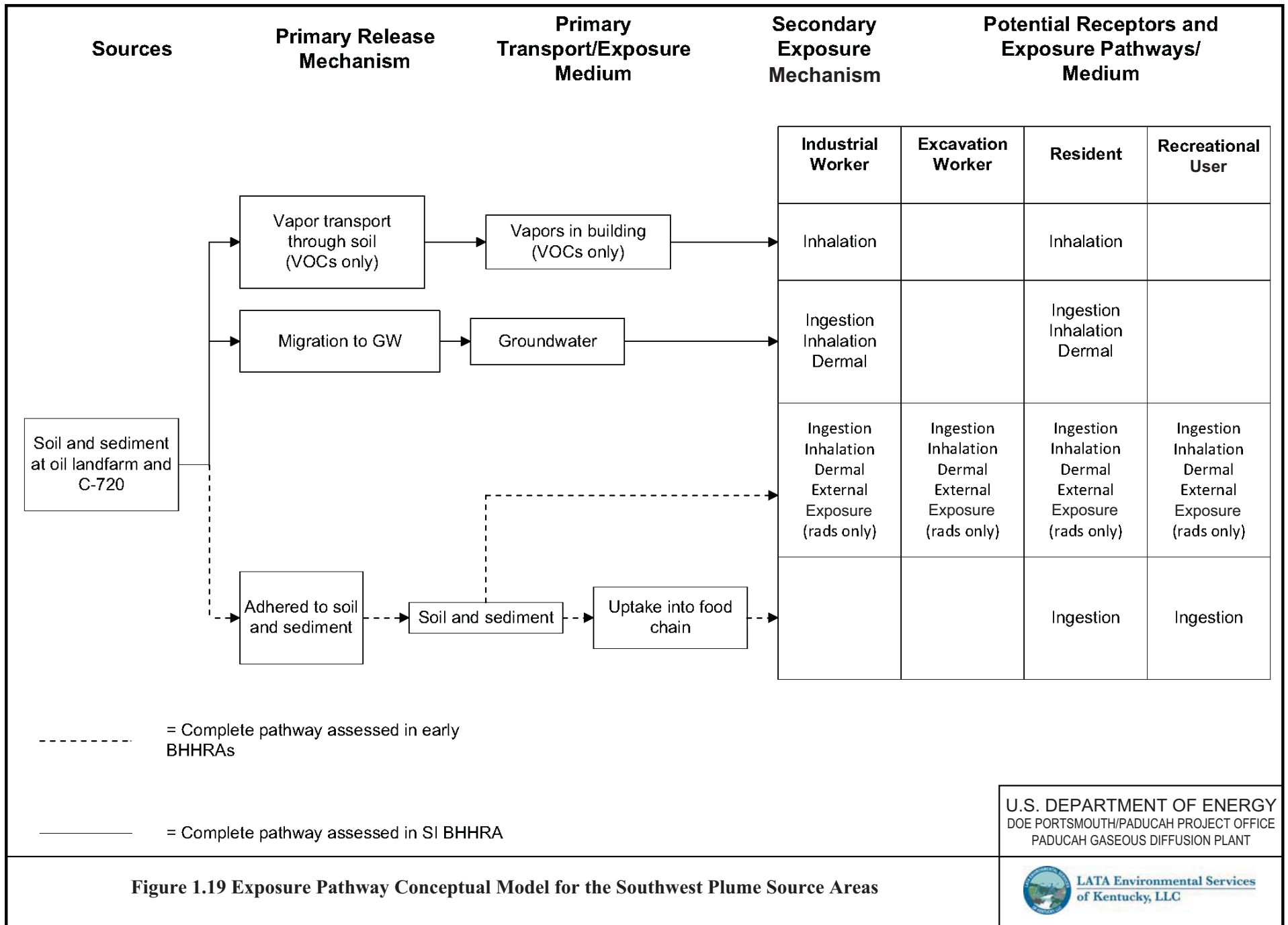

Figure 1.18. Conceptual Model for the C-720 TCE Source Areas



U.S. DEPARTMENT OF ENERGY  
DOE PORTSMOUTH/PADUCAH PROJECT OFFICE  
PADUCAH GASEOUS DIFFUSION PLANT



Figure 1.19 Exposure Pathway Conceptual Model for the Southwest Plume Source Areas



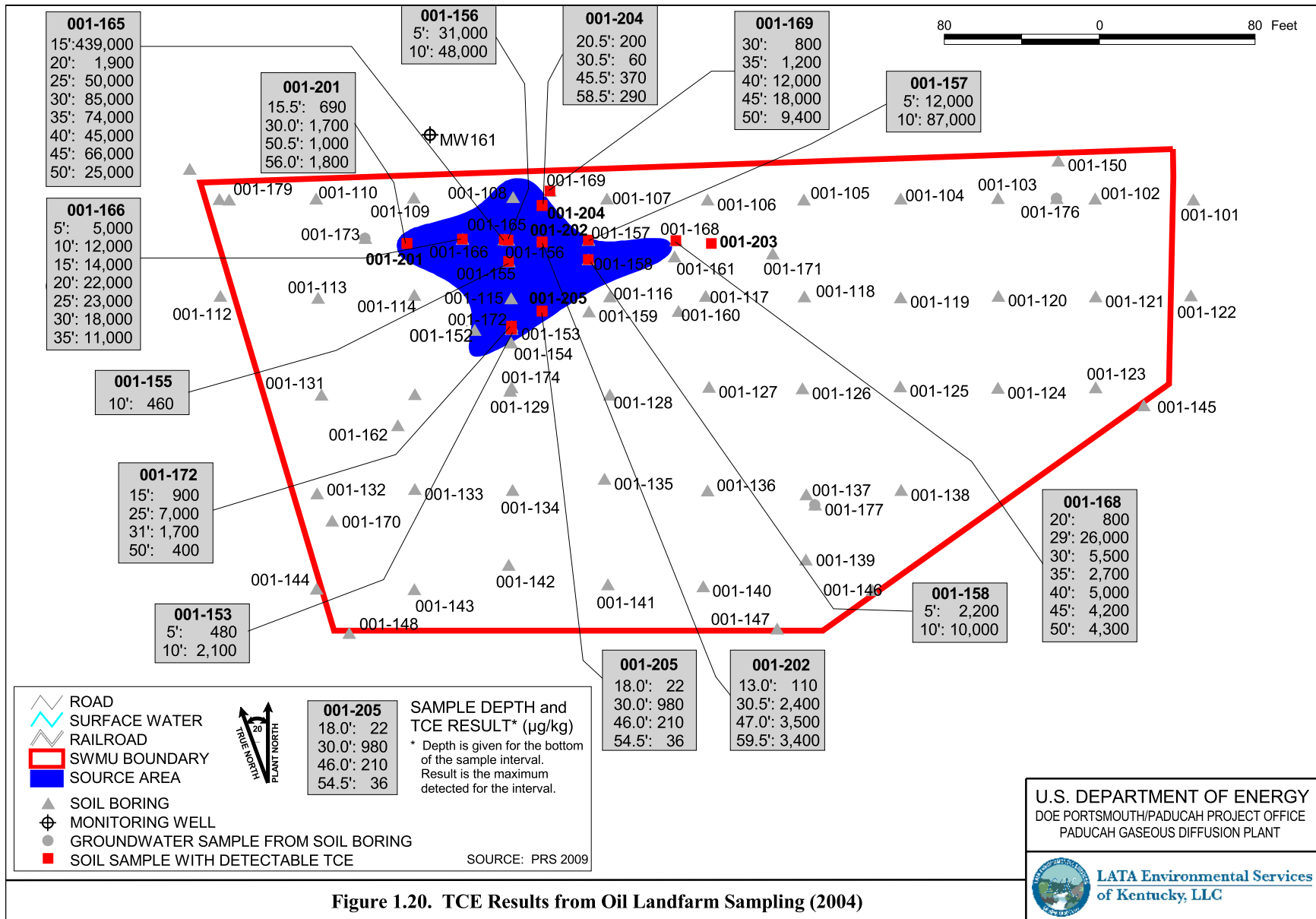

Figure 1.20. TCE Results from Oil Landfarm Sampling (2004)

TCE levels in the RGA are highest below the Oil Landfarm at the top of the RGA and directly downgradient of the source zone. Mixing of the Oil Landfarm leachate with groundwater in the RGA reduces TCE levels from the Oil Landfarm in the RGA by an order of magnitude and eventually to lesser levels downgradient. As the TCE plume migrates downgradient, area recharge from the overlying UCRS displaces the plume deeper in the RGA. Figure 1.17, adapted from the WAG 27 RI Report (DOE 1999a), illustrates the pictorial CSM for TCE contamination from the Oil Landfarm.

**Oil Landfarm Site Conditions.** Investigations on the Oil Landfarm include the Phase I and Phase II SIs (CH2M HILL 1991; CH2M HILL 1992), additional sampling performed to support the *Feasibility Study for the Waste Area Group 23 and Solid Waste Management Unit 1 of Waste Area Group 27 at the Paducah Gaseous Diffusion Plant, Paducah, Kentucky*, (DOE 1996a) and resulting Removal Action (DOE 1998a), and the WAG 27 RI. These investigations and actions identified VOCs, PCBs, dioxins, semivolatile organic compounds (SVOCs), heavy metals, and radionuclides as COCs. As part of the WAG 23 Removal Action, 17.58 m<sup>3</sup> (23 yd<sup>3</sup>) of dioxin-contaminated soil was excavated and removed from the unit. Samples collected in a WAG 23 focused sampling event in February of 1996 from SWMU 1 indicated the presence of *cis*-1,2-dichloroethene (*cis*-1,2-DCE) concentrations as high as 2,400 milligrams per kilogram (mg/kg). Results of the WAG 23 focused sampling were published in the WAG 23 FS (DOE 1996a). During the WAG 27 RI, the maximum detected TCE concentration was 439 mg/kg at 4.6 m (15 ft) bgs, with most TCE concentrations less than 100 mg/kg. Sampling locations from the WAG 27 RI are shown in Figure 1.20. TCE was not detected above method detection limits (MDLs) at any locations with the exception of the locations and results summarized in Figure 1.20.

During the Southwest Plume SI, five borings (001-201 through 001-205) were placed within and adjacent to the soil contamination area defined during the WAG 27 RI (Figure 1.20). Soil samples were collected for analysis from the vadoze zone above the RGA. Borings did not exceed 18.3 m (60 ft) and were not advanced past the UCD. Soil samples were collected at approximately 4.6-m (15-ft) intervals. Sampling intervals were modified to reflect the MIP profile. No groundwater samples were collected during the investigation of this unit. Results from SI sampling are shown in Figure 1.20.

The diagrammatic CSM in Figure 1.19 includes the pathways evaluated in the SI Baseline Human Health Risk Assessment (BHHRA) as well as pathways evaluated in earlier BHHRAs. The CSM shows that chemicals of potential concern in soil could reach receptors through direct exposure to contaminants in soil and through migration of contaminants to groundwater to which receptors could be exposed through drinking, showering, and household water use. The remaining exposure pathway shown in the CSM in Figure 1.19 involves exposure to vapors transported through soil into buildings. This vapor pathway is complete only for the VOC contaminants at these source areas. The SI BHHRA conducted a new risk assessment for this vapor pathway and for exposures to groundwater. The earlier BHHRAs evaluated direct exposure to soil and consumption of biota exposed to contaminated soil. The results of those risk assessments are summarized in Appendix D of this FFS. The earliest risk assessments included potential exposure through consumption of fish from contaminated surface water; however, the fish consumption pathway never was evaluated quantitatively for any on-site receptors and, therefore, was not included in the current CSM diagram.

The highest levels of total VOCs detected in a single sample included TCE (3.5 mg/kg) and degradation products, *cis*-1,2-DCE (1.5 mg/kg) and VC (0.02 mg/kg); TCA (0.05 mg/kg); and 1,1-DCE (0.07 mg/kg). Some or all of these products were detected in samples from all sample intervals at the location collected to a depth of 18.1 m (59.5 ft). The high TCE concentration (3.5 mg/kg) was detected at 14.3 m (47 ft) bgs. Significant levels of TCE (1.8 mg/kg) and *cis*-1,2-DCE (0.086 mg/kg) were detected in a second location from all intervals collected to a depth of 17.07 m (56 ft), with the highest level of TCE detected at 17.07 m (56 ft) bgs. A third location exhibited lower levels of TCE and its degradation products, with the highest level of TCE (0.98 mg/kg) detected at 9.1 m (30 ft) bgs together with TCA (0.0034 mg/kg). Low levels of

TCE (0.37 mg/kg) and *cis*-1,2-DCE (0.2 mg/kg), were detected at 13.8 m (45.5 ft) in a fourth sample location. The fifth location did not contain any detectable concentrations of TCE or its degradation products, but had a slight detection of carbon disulfide (0.014 mg/kg) at 10.1 m (33 ft), which was the only contaminant above the MDL. The presence of daughter products of anaerobic biodegradation of chlorinated solvents and other markers of anaerobic biodegradation (i.e., carbon disulfide) indicate conditions suitable for enhanced anaerobic biodegradation are present at some locations in the vicinity of the Oil Landfarm.

**C-720 Building Area CSM.** The conceptual model for the C-720 Building Area is similar to the Oil Landfarm, although the release mechanisms are dissimilar. In the C-720 Building Area model, the largest TCE source zone is below and adjacent to the outlet for the storm drain on the east end, south side of the C-720 Building, or a nearby storm sewer inlet for the parking lot. In either case, the interval of contaminated soils extends from the base of the storm sewer [1.52-m (5-ft) depth] to the base of the UCRS [18.3-m (60-ft) depth]. Soil TCE levels are elevated throughout the entire depth of the UCRS within the source zone, but the TCE levels are significantly lower in the soils above the water table, which averages a depth of 4.6 m (15 ft) bgs in this part of the C-720 Building Area.

Repeated TCE releases potentially allowed DNAPL to accumulate and eventually migrate as a free-phase liquid through the UCRS; however, sufficient time has passed to dissolve the DNAPL so that only potential ganglia of TCE DNAPL remain. The water table is at a depth of approximately 4.6 m (15 ft). Soil TCE levels are elevated throughout the entire depth of the UCRS within the source zone, but the TCE levels are significantly lower in the soils above the water table where volatilization has been more effective.

Although there have been infrequent historical detections of dissolved TCE levels within the source zone exceeding 10,000 µg/L (which is consistent with the presence of free-phase TCE in ganglia), no dissolved-phase concentrations greater than 10,000 µg/L have been detected in the UCRS or RGA water in the area of the Oil Landfarm for more than 10 years. Shallow groundwater flow is dominantly vertical. Once the contamination reaches the RGA, flow becomes horizontal. TCE levels in the leachate from the C-720 Building Area are diluted by an order of magnitude when mixed with RGA groundwater, with the concentrations further declining with distance in a downgradient direction. Figure 1.18, the pictorial site conceptual model of the C-720 Building Area TCE contamination, is taken from the WAG 27 RI Report (DOE 1999a).

**C-720 Northeast Site Conditions.** The maximum TCE concentration detected (8.1 mg/kg) in the WAG 27 RI was in a sample 9.1 m (30 ft) bgs located immediately north of the parking lot. The WAG 27 RI sampling location and results are shown in Figure 1.21. During the Southwest Plume SI (DOE 2007), investigation of soils of the C-720 Northeast Site consisted of six borings (720-101 through 720-106) placed between the north edge of the parking lot and a storm sewer to which all surface runoff for the parking lot flows (Figure 1.21). Because the conceptual release mechanism for the C-720 Northeast Site is routine equipment cleaning and rinsing performed in the area in the past, locations were selected to sample areas associated with these activities. Borings did not exceed 18.3 m (60 ft), and soil samples were collected at approximately 4.6-m (15-ft) intervals. Sampling intervals were modified to reflect the MIP profile. Analytical results below the soil background levels at PGDP were not included in the discussion of this investigation.

Results indicated that soils containing very low levels of VOC contamination were detectable in the subsurface of the northeast corner of the C-720 Building Area. The highest level of TCE (0.98 mg/kg) detected during the SI sampling event was at 15.1 m (49.5 ft) bgs, with low levels of *cis*-1,2 DCE (0.05 mg/kg) and 1,1-DCE (0.02 mg/kg) detected. Carbon disulfide (0.005 mg/kg) was detected at this location as well, but was not detected at any other locations during investigation of the northeast corner source

area. The second highest sample identified a maximum TCE concentration of 0.63 mg/kg at 17.2 m (56.5 ft), with no degradation products detected above the MDLs. A third location had a similar maximum TCE level of 0.6 mg/kg at 14 m (46 ft) and included *cis*-1,2-DCE (0.019 mg/kg). The remaining three locations had low levels of TCE (0.01 to 0.06 mg/kg) and degradation products and other VOCs including tetrachloroethene, 1,2-dichloroethane, 1,1-DCE, carbon tetrachloride, and chloroform detected. The results confirmed that contamination had migrated to the area's deeper soil. Results from SI sampling are shown in Figure 1.21.

Samples from the well cluster MW203 (RGA) and MW204 (UCRS) were the only groundwater samples collected during the investigation of this unit (see monitoring well locations on Figure 1.21). The TCE levels declined from the UCRS to the RGA wells (280 to 99 µg/L).

**C-720 Southeast Site Conditions.** In the WAG 27 RI, the maximum TCE concentration detected was 68 mg/kg at 6.4 m (21 ft) bgs. Sampling locations and results are shown in Figure 1.21. During the Southwest Plume SI, two borings were placed through the parking lot adjacent to the C-720 Building loading dock. No groundwater samples were collected during investigation of this unit. Samples had low levels of TCE [maximum 0.20 mg/kg at 8.84 m (29 ft) bgs] with no associated degradation products. The results indicated that the locations sampled were at the periphery of the source area defined in the WAG 27 RI. Results from SI sampling are provided on Figure 1.21.

**Storm Sewer.** The initial phase for the Southwest Plume SI of the Storm Sewer involved verifying the integrity of the Storm Sewer itself. Any breaks or cracks in the Storm Sewer could act as potential pathways for contamination. A video system was used to inspect approximately 914.4 m (3,000 ft) of the storm sewer from the east side of the C-400 Building to Outfall 008. The video indicated that the Storm Sewer had maintained its structural integrity. The actual physical properties of the Storm Sewer (diameter and length of pipe in sections) were different than expected in some areas, and these differences were documented for future reference. There were no significant holes or fractures visible in the Storm Sewer. The MIP/DPT samples were placed at locations near potential weaknesses in the storm sewer walls at depths of 5.73 and 6.1 m (18.8 to 20 ft) bgs, which is near but below the base of the storm sewer.

Soil sample results from the Southwest Plume SI indicated that low levels of VOCs were present in the backfill at the Storm Sewer (DOE 2007). No groundwater samples were taken during the investigation of this unit. A video survey that confirmed the integrity of the Storm Sewer, combined with the soil sampling results, demonstrated that the Storm Sewer was not a source of contamination to the Southwest Plume; therefore, the Storm Sewer was not carried forward in the FFS for alternative evaluation.

**Analytical Data.** Analytical data from previous investigations that were representative of current site conditions and met the requirements of the Risk Methods Document as well as the data collected during the most recent Southwest Plume SI were utilized in support of this evaluation (DOE 2001a). These datasets have been verified, validated, and assessed as documented in the respective investigations. The datasets were determined to meet the project goals and determined acceptable for use in decision making. Potential source areas, as determined by the analytical results, were examined, and potential site-related contaminants were identified.

### **DOE Plant Controls**

DOE plant controls associated with the Oil Landfarm and the C-720 Area Northeast and Southeast sites are established and maintained outside of the CERCLA process and are not identified as land use controls (LUCs) for this action; however, are they effective at preventing public access and trespassers to contaminated areas of the facility and consist of the following:

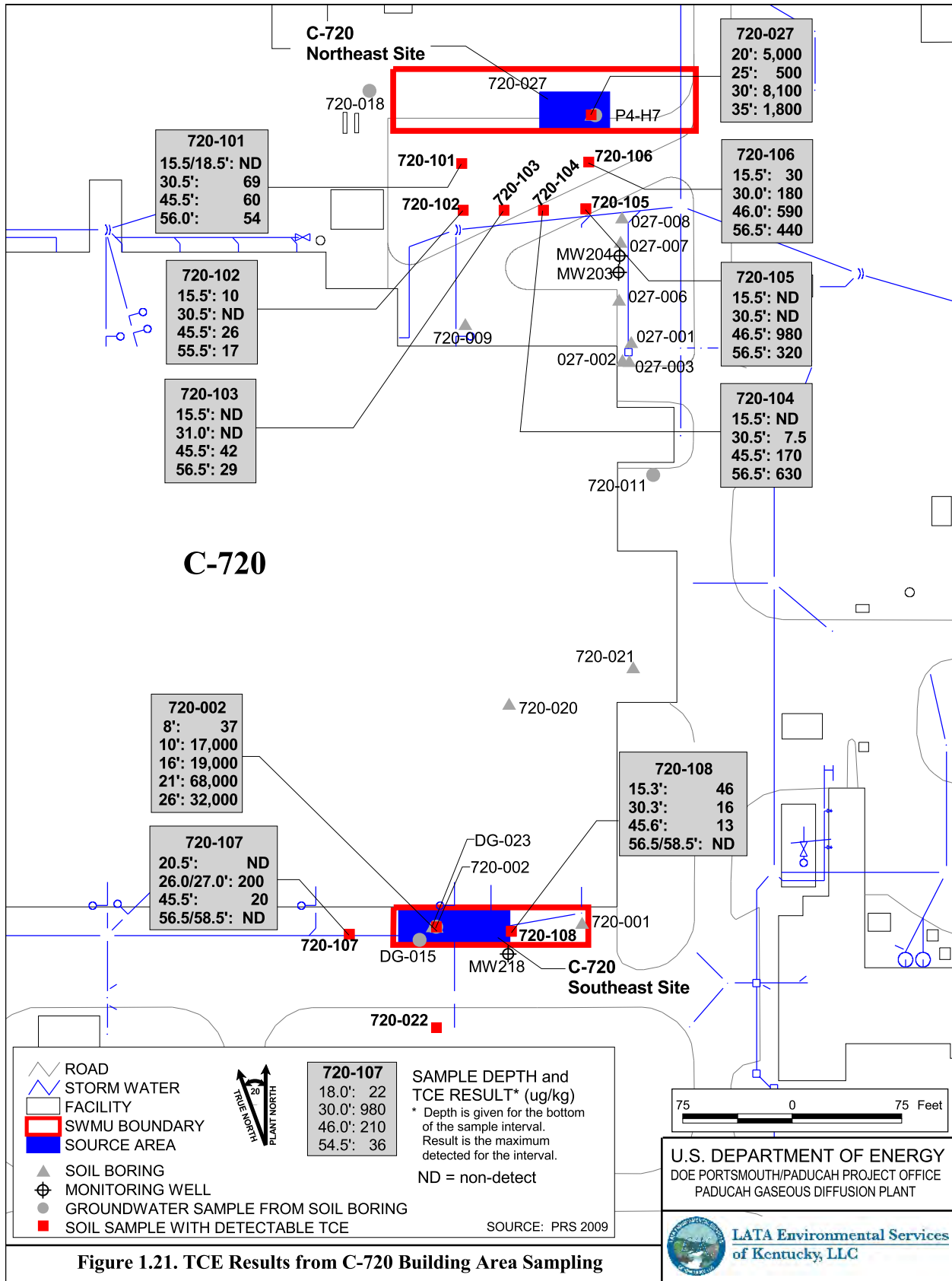

Figure 1.21. TCE Results from C-720 Building Area Sampling

Figure No. C5AC90005SK007R3\_5\_1.21.apr  
DATE 12-03-2010

- The sites are within areas protected from trespassing under the 1954 Atomic Energy Act as amended (referred to as the 229 Line). These areas are posted as “no trespassing” and trespassers are subject to arrest and prosecution. Physical access to the PGDP is prohibited by security fencing, and armed guards patrol the DOE property 24 hours per day to restrict workers entry and prevent uncontrolled access by the public/site visitors. Vehicle access to the sites is restricted by passage through Security Post 57 and by the plant vehicle protection barrier.
- The sites are in areas that are subject to routine patrol and visual inspection by plant protective forces, at a minimum once per shift.
- Protection of the current PGDP industrial workers is addressed under DOE’s Integrated Safety Management System/Environmental Management System program and 29 *CFR* § 1910. Interim work area controls that may be used under these programs during implementation of a remedy include warning and informational postings, temporary fencing and/or barricades, and visitor sign-in controls. These controls will be included in the Remedial Action Work Plan (RAWP) and depicted in a figure of appropriate scale. Upon completion of the active remedial action, these controls would cease.

Section XLII of the FFA requires the sale or transfer of the site to comply with Section 120(h) of CERCLA. In the event DOE determines to enter into any contract for the sale or transfer of any portion of PGDP, DOE will comply with the applicable requirements of Section 120(h) in effectuating that sale or transfer, including all notice requirements. Proprietary institutional controls such as deed notices and environmental covenants in the deed will be evaluated and addressed, as necessary, as LUCs in the Soils and Groundwater OU projects. In addition, DOE will notify EPA and Kentucky of any such sale or transfer at least 90 days prior to such sale or transfer.

## **1.2.4 Contaminant Fate and Transport**

### **1.2.4.1 Previous modeling**

Previous fate and transport modeling of selected VOCs (TCE, *cis*-1,2-DCE, *trans*-1,2-DCE, and VC) in subsurface soil to RGA groundwater was conducted as part of the Southwest Plume SI. See Appendix C, Modeling Methodology for additional information and results of the modeling. The BHHRA used these modeling results to estimate the future baseline risks that might be posed to human health and the environment through contact with groundwater impacted by contaminants migrating from the Oil Landfarm and C-720 Building Area to four points of exposure (POEs). The POEs assessed were at the source, the plant boundary, DOE property boundary, and near the Ohio River. This analysis was initiated after it was observed that cleanup levels protective of a rural resident using groundwater drawn from a well at the PGDP property boundary were similar to or less than the average concentrations of TCE in the Oil Landfarm and C-720 Building Area sources (DOE 2007).

Inhalation of vapor released from the groundwater into home basements was modeled quantitatively for rural residents based on measured TCE, *cis*-1,2-DCE, *trans*-1,2-DCE, and VC concentration at the Oil Landfarm and the C-720 Building area, as well as modeled TCE concentrations at the plant and property boundaries. The potential air concentrations were used for estimating excess lifetime cancer risk (ELCR) and hazard for the hypothetical future on- and off-site rural resident. Additional fate and transport modeling was conducted during the FFS to support evaluation of remedial alternatives and to calculate soil remedial goals.

### **1.2.4.2 Properties of site-related chemicals**

Generally, the fate and transport of TCE and its degradation products (*cis*-1,2-DCE, *trans*-1,2-DCE, and

VC), which are organic compounds, are functions of both site characteristics and the physical and chemical interactions between the contaminants and the environmental media with which they come into contact. The physical and chemical properties of the contaminants that influence these interactions include, but are not limited to, (1) their solubility in water, (2) their tendency to transform or degrade (usually described by an environmental half-life in a given medium), and (3) their chemical affinity for solids or organic matter (usually described by partitioning coefficients [e.g.,  $K_d$ ,  $K_{oc}$ ,  $K_{ow}$ ]).

**TCE and its Degradation Products.** TCE and its degradation products may be degraded in the environment by various processes including hydrolysis, oxidation/reduction, photolysis, or biodegradation. Both aerobic and anaerobic degradation of TCE may occur. Although degradation may reduce the toxicity of a chemical, in the case of TCE, degradation may result in more toxic degradation products, such as VC. Both *cis*- and *trans*-1,2-DCE may be indicators of reductive dechlorination for this degradation pathway or contaminants of industrial grade TCE. The biochemical degradation pathway for TCE is as follows:

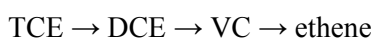

**Degradation Rates.** In a report entitled *Evaluation of Natural Attenuation Processes for Trichloroethylene and Technetium-99 in the Northeast and Northwest Plumes at the Paducah Gaseous Diffusion Plant, Paducah, Kentucky, KY/EM-113*, (LMES 1997) biodegradation rates of 0.026 to 0.074 year<sup>-1</sup> were estimated. These biodegradation rates correspond to TCE half-lives of 26.7 and 9.4 years, respectively. The Idaho National Laboratory is one of a few aerobic aquifer settings where dissolved TCE degradation rates have been documented. *An Evaluation of Aerobic Trichloroethene Attenuation Using First-Order Rate Estimation* (Sorenson *et al.* 2000) determined that the TCE degradation half-life for Idaho National Laboratory ranged between 13 and 21 years, which compares favorably to the rates determined for PGDP. The *PGDP TCE Biodegradation Investigation Summary Report Regional Gravel Aquifer and Northwest Plume* (KRCEE 2008) provides additional information on the current understanding of aerobic degradation studies performed at PGDP.

Recently, as part of the development of response actions including the Southwest Plume SI, DOE completed fate and transport modeling for PGDP using revised biodegradation rates for the RGA. The revised biodegradation rates were developed using regulator accepted methods presented in *Technical Protocol for Evaluating Natural Attenuation of Chlorinated Solvents in Groundwater* (EPA 1998b) and data from the Northwest Plume, the most thoroughly characterized of the dissolved-phase plumes at PGDP. Sampling results collected from the Northwest Plume indicate that TCE concentrations decrease with distance at a faster rate than selected inorganic contaminants [i.e., chloride and technetium-99 (Tc-99)]. Analyses using these inorganic tracers yielded a dissolved-phase TCE degradation factor with a range of 0.0614 to 0.2149 year<sup>-1</sup>. This degradation factor corresponds to a TCE half-life of 11.3 to 3.2 years, respectively. Appendix F of the Southwest Plume SI presents a detailed discussion of the derivation of this degradation rate.

TCE degradation rates in the UCRS have not been determined. Investigation of TCE degradation in the UCRS is an ongoing project.

A review of existing literature regarding chemical and physical parameters, including half-lives, for TCE was conducted for the California Environmental Protection Agency and presented in *Intermedia Transfer Factors for Contaminants Found at Hazardous Waste Sites: Trichloroethylene (TCE), Final Draft Report* (Cal/EPA 1994). Reaction half-life values reported in scientific literature were compiled and averaged. Reported values for the reaction half-life of TCE in vadose-zone soil ranged from 33 to 2,888 days (approximately 0.09 to 7.9 years) with a mean of 760 days (approximately 2.1 years). The reported values for the reaction half-life of TCE in groundwater were very similar, ranging from 128 to 2,888 days

(approximately 0.35 to 7.9 years) with a mean of 800 days (approximately 2.2 years). Biodegradation half-lives can vary dramatically in response to site-specific geochemical conditions; thus, experiences at other locations may not be reliably applied to the PGDP site.

**Mobility.** The mobility of TCE and its degradation products, like all organic compounds, is affected by its volatility, its partitioning behavior between solids and water, water solubility, and concentration. The Henry's Law constant value (KH) for a compound is the ratio of the compound's vapor pressure to its aqueous solubility. The KH value can be used to make general predictions about the compound's tendency to volatilize from water. Vapor pressure is a measure of the pressure at which a compound and its vapor are in equilibrium. The value can be used to determine the extent to which a compound would travel in air, as well as the rate of volatilization from soils and solution. TCE and its degradation products have high vapor pressures and Henry's Law constants, indicating a potential for volatilization; therefore, they are not expected to persist in surface soils. The rate of loss from volatilization depends on the compound, temperature, soil gas permeability, and chemical-specific vapor pressure.

Transport mechanisms for TCE include gravity-driven migration as a DNAPL. The range of  $K_{oc}$  values indicates that these chlorinated VOCs are relatively mobile through soils as dissolved constituents and tend not to partition significantly from water to soil; however, some of these compounds are retained in pore spaces in the form of DNAPLs. A DNAPL migrates principally under the influence of gravity and will migrate vertically, fingering out among available pore space. As it migrates downward, capillary forces act to retain a portion of the DNAPL within the soil matrix. This retained portion, called residual saturation, is at equilibrium with pressure, gravity, and capillary forces. DNAPL at residual saturation will remain entrapped unless the balance of forces changes. Depending upon the soil texture, entrapped residual organic saturations may vary from approximately 4% to 10% of the pore space in the unsaturated soil zone to as high as 20% of the pore space in the saturated zone (Abriola *et al.* 1998).

If a DNAPL is present in sufficient quantity, it may spread laterally along lower permeability zones it encounters and even pool there if a sufficiently large lower permeability zone exists. This type of migration allows a DNAPL to take a highly variable path and be difficult to fully characterize in areas where the geology is spatially variable, such as in the UCRS at PGDP.

**Solubility and sorption.** Water solubility and the tendency to sorb to particles or organic matter can correlate with retardation in groundwater transport. In general, organic chemicals with high solubilities are more mobile in water than those that sorb more strongly to soils. The following properties dictate an organic chemical's mobility within a specific medium.

- $K_{oc}$  (the soil organic carbon partition coefficient) is a measure of the tendency for organic compounds to be sorbed to the organic matter of soil and sediments.  $K_{oc}$  is expressed as the ratio of the amount of chemical sorbed per unit weight of organic carbon to the chemical concentration in solution at equilibrium.
- $K_{ow}$  (the octanol-water partition coefficient), is an indicator of hydrophobicity (the tendency of a chemical to avoid the aqueous phase) and is correlated with potential sorption to soils. It is also used to estimate the potential for bioconcentration of chemicals into tissues.
- $K_d$  (the soil/water distribution coefficient) is a measure of the tendency of a chemical to sorb to soil or sediment particles. For organic compounds, this coefficient is calculated as the product of the  $K_{oc}$  value and the fraction of organic carbon in the soils. In general, chemicals with higher  $K_d$  values sorb more strongly to soil/sediment particles and are less mobile than those with lower  $K_d$  values.



#### **1.2.4.3 Fate of DNAPL TCE in soil and groundwater**

The Southwest Plume source areas were determined as part of the Southwest Plume SI (DOE 2007) to contain residual DNAPL TCE through several lines of evidence, including the following:

- Process knowledge of use of separate-phase TCE, for example at the C-720 Northeast Site;
- Soil concentrations greater than those theoretically possible from dissolved-phase TCE in pore water only, as observed at the Oil Landfarm;
- Residual soil concentrations long after last TCE use, as observed at all of the source areas; and
- Concentrations of TCE and degradation products in the upper RGA of greater than 1,000 µg/L, as observed at the C-720 Northeast Site.

DNAPL TCE released to soils may be redistributed into multiple phases through processes including the following (ITRC 2005):

- Formation of a continuous fluid mass of pure phase, drainable DNAPL,
- Entrapment of residual pure-phase DNAPL within pores as discontinuous globules or ganglia,
- Dissolution from the DNAPL into groundwater,
- Sorption to organic and mineral constituents of the soils, and
- Volatilization into a gas phase in the unsaturated zone.

No evidence exists that DNAPL TCE released to UCRS soils at the Southwest Plume source areas continued to migrate to the RGA; therefore, any residual DNAPL exists as discontinuous globules or ganglia. Given the end of the operational period of the Oil Landfarm in 1979 and the suspected end of practices that resulted at the C-720 Building Area in the mid-to late 1980s, TCE in UCRS soils has had sufficient time for redistribution into all phases.

The presence of VOCs in UCRS groundwater was verified during the WAG 27 RI (DOE 1999a). TCE was detected in UCRS groundwater collected at the Oil Landfarm and at the C-720 Southeast Site at concentrations up to 312 µg/L and 93 µg/L, respectively.

Soil vapor sampling has not been performed at the Southwest Plume source areas; however, VOCs are expected to be present in the UCRS soil vapor due to partitioning into the air filled porosity from the residual DNAPL and from sorbed and aqueous phase VOCs. Each of the phases may be a significant contributor to the total mass of VOCs present in the UCRS.

#### **1.2.4.4 Vapor transport modeling**

Vapor transport modeling was conducted in the Southwest Plume SI to evaluate the potential air concentrations in a hypothetical residential basement from soil contamination at the Oil Landfarm and the C-720 Building Area. The Johnson and Ettinger model (1991) coded into spreadsheets by EPA (2004b) was used to assess the potential migration of VOCs into a basement. The results of the vapor transport model are presented in Table 1.3 and were used as the predicted household air concentrations for estimating ELCR and hazard for the adult rural hypothetical resident. The vapor hazard and cancer risk at the Oil Landfarm were 0.7 and 4.0E-05, respectively. At C-720, the vapor hazard was 4.8, and the vapor cancer risk was 7.8E-05. A summary of the risk assessment is provided in Section 1.2.5.

**Table 1.3. Basement Air Concentrations Based on Vapor Transport Modeling Results for FFS Source Areas**

Source Area	Contaminant	On-Site
		Air concentration (mg/m <sup>3</sup> )
C-720 Building Area	TCE	0.15
	<i>cis</i> -1,2-DCE	0.015
	<i>trans</i> -1,2-DCE	0.057
	Vinyl Chloride	0.008
Oil Landfarm	TCE	0.019
	<i>cis</i> -1,2-DCE	0.004
	<i>trans</i> -1,2-DCE	0.001
	Vinyl Chloride	0.0002

*cis*-1,2-DCE = *cis*-1,2-dichloroethene

TCE = trichloroethene

*trans*-1,2-DCE = *trans*-1,2-dichloroethene

### 1.2.5 Previous Baseline Risk Assessment

The Southwest Plume SI (DOE 2007) used historical information and newly collected data to develop a site model for each source area and presented a BHHRA and a screening ecological risk assessment (SERA). In the BHHRA, information collected during the Southwest Plume SI and results from previous risk assessments were used to characterize the baseline risks posed to human health and the environment resulting from contact with contaminants in groundwater drawn from the Southwest Plume in the RGA at the source areas. In addition, fate and transport modeling was conducted, and the BHHRA used these modeling results to estimate the future baseline risks that might be posed to human health and the environment through contact with groundwater impacted by contaminants migrating from the Oil Landfarm and C-720 Building Area to four POEs. The POEs assessed were at the source, the plant boundary, property boundary, and near the Ohio River. Vapor transport modeling was conducted and the potential air concentrations also used as the predicted household air concentrations for estimating ELCR and hazard for the hypothetical future on- and off-site rural resident. Additional summary of the SI Baseline Risk Assessment is provided in Appendix D.

Because data collected during the SI focused on the collection of subsurface soil and groundwater data to delimit the potential sources of contamination to the Southwest Plume, the new material developed in the BHHRA and SERA was limited to risks posed by contaminants migrating from potential source areas to RGA groundwater and by direct contact with contaminated subsurface soils and groundwater in the source areas.

**Baseline Risk Assessment Conclusions.** For both the Oil Landfarm and the C-720 Building Area, the cumulative human health ELCR and hazard index (HI) exceeded *de minimis* levels [i.e., a cumulative ELCR of  $1 \times 10^{-6}$  or a cumulative HI of 1] in the PGDP Risk Methods Document for one or more scenarios. Additionally, risks from household use of groundwater by a hypothetical on-site rural resident also exceeded those standards. The land uses and media assessed for ELCR and HI to human health for each potential source area were taken from earlier assessments with the exception of groundwater use and vapor intrusion by the hypothetical future on- and off-site rural resident. These were newly derived in the BHHRA from measured and modeled data collected during the Southwest Plume SI and previous investigations.

In the BHHRA, it was determined that the hypothetical rural residential use of groundwater scenario and vapor intrusion are of concern for both ELCR and HI at each source area, except the Storm Sewer, which is of concern for ELCR only. The exposure routes of ingestion of groundwater, inhalation of gases emitted while using groundwater in the home, and vapor intrusion from the groundwater into basements account for about 90% of the total ELCR and HI.

For groundwater use by the hypothetical adult resident at the Oil Landfarm, VOC COCs include TCE; *cis*-1,2-DCE; chloroform; and 1,1-DCE, all of which are “Priority COCs” (i.e., chemical-specific HI or ELCR greater than or equal to 1 or  $1 \times 10^{-4}$ , respectively), except for 1,1-DCE. The VOCs make up 78% of a cumulative ELCR of  $6.8 \times 10^{-4}$  and 76% of a cumulative HI of 26. For groundwater use by the hypothetical child resident, VOC COCs include TCE; *cis*-1,2-DCE; and chloroform, all of which are “Priority COCs.” These VOCs make up 85% of a cumulative HI of 99.

At the C-720 Building Area, the VOC COCs for groundwater use by the hypothetical adult resident include TCE; *cis*-1,2-DCE; VC; and 1,1-DCE, with all except VC being “Priority COCs.” The VOCs make up 93% of a cumulative ELCR of  $1.8 \times 10^{-3}$  and 57% of the cumulative HI of 23. For groundwater use by the hypothetical child resident, VOC COCs include TCE; *cis*-1,2-DCE; *trans*-1,2-DCE; and 1,1-DCE, all of which are “Priority COCs,” except for *trans*-1,2-DCE. The VOCs make up 76% of a cumulative HI of 102.

At the Storm Sewer, the adult hypothetical residential COCs include TCE and 1,1-DCE, neither of which is a “Priority COC.” The VOCs make up 100% of a cumulative ELCR of  $7.9 \times 10^{-6}$ . The HI for the storm sewer was less than 1 and, therefore, not of concern. For groundwater use by the hypothetical child resident at the Storm Sewer, COCs include TCE and 1,1-DCE, neither of which is a “Priority COC.” The VOCs make up 100% of a cumulative HI of 0.6 for the child hypothetical resident.

At the property boundary for the hypothetical adult resident, the migrating COCs from the Oil Landfarm are TCE and VC, with no “Priority COCs.” The VOCs make up 100% of the total ELCR of  $1.4 \times 10^{-6}$  and the HI is less than 0.1. For the hypothetical child resident at the property boundary, the COCs are TCE and *cis*-1,2-DCE with no “Priority COCs.” The VOCs make up 85% of a cumulative HI of 0.4 for the hypothetical child resident.

The COC migrating from the C-720 Building Area to the hypothetical adult resident at the property boundary is VC, which is not a “Priority COC.” The VC makes up greater than 95% of the total ELCR of  $1.1 \times 10^{-6}$ , and the HI is less than 0.1. For the hypothetical child resident at the property boundary, the HI is less than 0.1. Based on the previous and current modeling results, neither metals nor radionuclides are COCs for contaminant migration from the Oil Landfarm or C-720 Building Area.

The SERA, which used results taken from the Baseline Ecological Risk Assessment completed as part of the WAG 27 RI, concluded that a lack of suitable habitat in the industrial setting at the Oil Landfarm and the C-720 Building Area precluded exposures of ecological receptors under current conditions; therefore, it was determined during problem formulation that an assessment of potential risks under current conditions was unnecessary.

**Uncertainty Associated with Risk in Soils.** Although previous analyses have indicated that non-VOC contaminants are present in surface and subsurface soils and may present an unacceptable risk (see Appendix D), there exists uncertainty as to whether non-VOC contaminants currently are present at levels that pose an unacceptable risk to human health. The uncertainty arises from changes in toxicity values, changes in exposure parameters, and the current level of contaminants present at the Oil Landfarm after completion of a previous removal action. The presence or absence of an unacceptable risk will be addressed as part of the Soils OU.

## 2. IDENTIFICATION AND SCREENING OF TECHNOLOGIES

Technology types and process options that may be applicable for remediation of Southwest Plume sources are identified, screened, and evaluated in this section. A primary objective of this FFS is to identify remedial technologies and process options that potentially meet the RAOs for this action and then combine them into a range of remedial alternatives. The potential remedial technologies are evaluated for implementability, effectiveness, and relative cost in eliminating, reducing, or controlling risks to human health. The criteria for identifying, screening, and evaluating potentially applicable technologies are provided in EPA's *Guidance for Conducting Remedial Investigations and Feasibility Studies Under CERCLA* (EPA 1988) and the NCP.

CERCLA, the NCP, and EPA guidance require development and evaluation of a range of responses, including a no-action alternative, to ensure that an appropriate remedy is selected. The selected final remedy must comply with ARARs and must protect human health and the environment. The technology screening process consists of the following series of steps:

- Identifying general response actions (GRAs) that may meet RAOs, either individually or in combination with other GRAs;
- Identifying, screening, and evaluating remedial technology types for each GRA; and
- Selecting one or more representative process options (RPOs) for each technology type.

Following the technology screening, the RPOs are assembled into remedial alternatives that are evaluated further in the detailed and comparative analyses of alternatives.

### 2.1 INTRODUCTION

Previous PGDP investigations and reports used to develop the conceptual site model and to identify and screen remedial technologies include the following:

- WAG 27 RI (DOE 1999a). This investigation focused on groundwater contaminant sources at the Oil Landfarm; SWMU 91 (UF<sub>6</sub> Cylinder Drop Test Site); SWMU 196 (C-746-A Septic Systems); and the C-720 Building Area. Geology, hydrogeology, and DNAPL source area descriptions were obtained from this source.
- *Feasibility Study for the Groundwater Operable Unit at Paducah Gaseous Diffusion Plant, Paducah, Kentucky* (DOE 2001b). This report refined the conceptual models for DNAPL distribution at source areas and identified and evaluated alternatives for remediating contaminated groundwater and source areas. Technology identification and screening were reviewed and updated as necessary and incorporated in the FFS.
- *Innovative Treatment and Remediation Demonstration (ITRD), Paducah Groundwater Project Innovative Technology Review* (Hightower *et al.* 2001). Technology identification and screening were reviewed, updated as necessary, and incorporated in the FFS.
- *Evaluation of Groundwater Management/Remediation Technologies For Application to the Paducah Gaseous Diffusion Plant* (KRCEE 2005). This report updated the previous ITRD (Hightower *et al.*

2001) in light of results of field demonstrations of soil and groundwater remedial technologies. This report was used primarily to aid in evaluation of technologies selected as RPOs.

- Southwest Plume SI (DOE 2007). This report described investigations at Southwest Plume source areas and further refined the site conditions. This report was the primary source for description of nature and extent of DNAPL source areas and source area lithology.

Other sources used in technology identification and screening, including EPA, DOE, and peer-reviewed databases and reports and journal publications, are cited and references provided.

Technologies and remedial alternatives are identified and evaluated in this FFS based on their effectiveness in reducing or eliminating contaminant sources including PTW, eliminating or mitigating the release mechanisms, or eliminating the exposure pathways for the Oil Landfarm and the C-720 Area Northeast and Southeast Sites.

## **2.2 REMEDIAL ACTION OBJECTIVES AND REMEDIATION GOALS**

The RAOs and remediation goals (RGs) for the Southwest Plume FFS are identified in this section. RAOs consist of site-specific goals for protecting human health and the environment (EPA 1988) and meeting ARARs. The media and COCs to be addressed are discussed in Section 1 and ARARs are identified and discussed in Section 4. The following RAOs for the Southwest Plume were developed by a working group comprised of the DOE, Paducah Remediation Services, LLC, EPA, and the Commonwealth of Kentucky:

- (1) Treat and/or remove PTW consistent with the NCP.
- (2a) Prevent exposure to VOC contamination in the source areas that will cause an unacceptable risk to excavation workers (< 10 ft).
- (2b) Prevent exposure to non-VOC contamination and residual VOC contamination through interim LUCs within the Southwest Plume source areas (i.e., SWMU 1, SWMU 211-A, and SWMU 211-B) pending remedy selection as part of the Soils OU and the Groundwater OU.
- (3) Reduce VOC migration from contaminated subsurface soils in the treatment areas at the Oil Landfarm and the C-720 Northeast and Southeast sites so that contaminants migrating from the treatment areas do not result in the exceedance of MCLs in underlying RGA groundwater.

Worker protection RGs are VOC concentrations in soils present at depths of 0-10 ft that would meet RAO #2a with no other controls necessary. Worker protection RGs were obtained from the Action Levels for the excavation worker stated in Appendix A, Table A.4, of the *Methods for Conducting Risk Assessments and Risk Evaluations at the Paducah Gaseous Diffusion Plant Paducah, Kentucky* (DOE 2010c). Worker protection RGs for VOCs in the source areas at levels of protection ranging from ELCR of 1E-04 to 1E-06, and HIs of 1E-01 to 3 are provided in Table 2.1.

For purposes of the FFS, the treatment zone encompasses the soils directly below and within the boundaries of the Oil Landfarm and C-720 Northeast and Southeast sites. Soil RGs calculated for the purposes of this document are based on VOC contaminant concentrations in soil that would not result in exceedance of the MCLs in the RGA groundwater and with no other controls necessary. The treatment zone where the RGs will be met are shown in Figures 1.20 and 1.21 for the Oil Landfarm and C-720 Northeast and Southeast Sites, respectively.

Groundwater modeling was conducted deterministically using the methodology presented in Appendix C to determine the groundwater protection RGs. The groundwater protection RGs are provided in Table 2.2. The RGs were calculated for TCE half-lives in UCRS soils ranging from 5 years to 50 years to assess the effects of high to low rates of degradation on overall remedy time frames (50 years essentially representing no observable degradation). Other VOCs were assumed not to be degraded. It is expected that as part of the ROD the RGs for RAO #3 will be revisited and assessed in detail with regard the components of the selected remedy.

**Table 2.1. Worker Protection RGs for VOCs at the C-720 Area and the Oil Landfarm Source Areas, mg/kg<sup>a</sup>**

VOC	ELCR 1E-06	ELCR 1E-05	ELCR 1E-04	HI = 0.1	HI = 1.0	HI =3.0
TCE	5.85E-02	5.85E-01	5.85E+00	1.93	19.3	57.9
1,1-DCE	6.26E-02	6.26E-01	6.26E+00	25	250	750
<i>cis</i> -1,2-DCE	NV	NV	NV	8.94	89.4	268.2
<i>trans</i> -1,2-DCE	NV	NV	NV	11.70	117	351
Vinyl chloride	1.10E-01	1.10E+00	1.10E+01	8	80	240

<sup>a</sup>Shaded RG values exceed the average concentration reported in Appendix C for the 0-10 ft interval at the Oil Landfarm and the C-720 Area.

ELCR = excess lifetime cancer risk  
 HI = hazard Index  
 NV = no value

**Table 2.2. Groundwater Protection RGs for VOCs at the C-720 Area and the Oil Landfarm Source Areas**

VOC	C-720 Northeast and Southeast Sites		UCRS Soil RG (mg/kg) <sup>a</sup>
	Half-Life (yr)	MCL (mg/L)	
TCE	5	5.00E-03	9.20E-02
TCE	25	5.00E-03	8.30E-02
TCE	50	5.00E-03	7.50E-02
1,1-DCE	infinite	7.00E-03	1.37E-01
<i>cis</i> -1,2-DCE	infinite	7.00E-02	6.19E-01
<i>trans</i> -1,2-DCE	infinite	1.00E-01	5.29E+00
Vinyl Chloride	infinite	2.00E-03	5.70E-01
<b>Oil Landfarm</b>			
TCE	5	5.00E-03	8.50E-02
TCE	25	5.00E-03	8.00E-02
TCE	50	5.00E-03	7.30E-02
1,1-DCE	infinite	7.00E-03	1.30E-01
<i>cis</i> -1,2-DCE	infinite	7.00E-02	6.00E-01
<i>trans</i> -1,2-DCE	infinite	1.00E-01	1.08E+00
Vinyl Chloride	infinite	2.00E-03	3.40E-02

<sup>a</sup>Based on a dilution attenuation factor of 59.

An uncertainty analysis was conducted, using probabilistic modeling, to evaluate the soil RGs for TCE. Time to attainment of RGs for each alternative retained after screening in Section 3 also was modeled. The methodology and results are described in Appendix C and are summarized in Section 4.

## **2.3 GENERAL RESPONSE ACTIONS**

GRAs are broad categories of remedial measures that produce similar results when implemented. The GRAs evaluated for this FFS include LUCs, containment, treatment, removal, and disposal. The identified GRAs may be implemented individually or in combination to meet the RAOs. Table 2.3 lists the GRAs, as well as the technology types and process options that flow down from each.

Formulation of a no-action alternative is required by the NCP [40 *CFR* § 300.430(e)(6)]. The no-action alternative serves as a baseline for evaluating other remedial action alternatives and generally is retained throughout the FS process. No action implies that no remediation will be implemented to alter the existing site conditions. As defined in CERCLA guidance (EPA 1988), no action may include environmental monitoring.

### **2.3.1 Interim LUCs**

Interim LUCs for the CERCLA sites at PGDP are summarized in Table A.1 (see Appendix A) and discussed in the following paragraphs.

- The excavation/penetration permit (E/PP) program will continue to provide protection against unauthorized exposure pending remedy selection as part of subsequent OUs that addresses relevant media.
- Warning signs which will be placed at the source areas at the beginning of the remedial action to provide warning of potential contaminant exposure will continue, pending remedy selection by subsequent OUs that addresses relevant media or until uncontrolled access is allowed.

### **2.3.2 Monitoring**

Technologies for monitoring are included under this GRA. Monitoring includes measurement methods to determine nature and extent of contamination, progress of cleanup, and site properties relevant to specific remediation technologies.

### **2.3.3 Monitored Natural Attenuation**

Monitored natural attenuation (MNA) relies on natural processes to achieve site-specific remedial objectives. Processes may include physical, chemical, or biological processes that reduce the mass, toxicity, mobility, volume, or concentration of contaminants in soil and groundwater. Monitoring of contaminant concentrations and process-specific parameters to ensure protection of human health and the environment during implementation is a critical element of MNA.

### **2.3.4 Removal**

RAOs potentially may be met by removing VOC-contaminated soils. Removal generates secondary wastes potentially requiring *ex situ* treatment and disposal or discharge.

**Table 2.3. Results of Technology Identification and Screening**

<b>General Response Action</b>	<b>Technology Type</b>	<b>Process Options</b>	<b>Screening Comments<sup>a</sup></b>
<b>LUCs</b>	Institutional controls	E/PP program	Technically implementable
	Physical controls	Warning signs	Technically implementable
<b>Monitoring</b>	Soil monitoring	Soil cores	Technically implementable
		Membrane interface probe	Technically implementable
		Soil vapor sampling	Technically implementable
		Soil moisture monitoring and sampling	Technically implementable
		Gore-sorbers	Technically implementable
		Raman spectroscopy	Technically implementable
	Groundwater monitoring	Sampling and analysis	Technically implementable
		Partitioning interwell tracer test	Low technical implementability
		Diffusion bags	Technically implementable
		Borehole fluxmeter	Technically implementable
		Ribbon NAPL Sampler	Technically implementable
DNAPL interface probe	Technically implementable		
<b>Monitored Natural Attenuation</b>	Monitoring and natural processes	Soil and groundwater monitoring; abiotic and biological processes	Technically implementable
<b>Removal</b>	Excavators	Backhoes, trackhoes	Technically implementable
		Vacuum excavation, remote excavator	Technically implementable
		Crane and clamshell	Technically implementable
		Large Diameter Auger	Technically implementable
<b>Containment</b>	Hydraulic containment	Recharge controls	Technically implementable.
		Groundwater extraction	Technically implementable only as a secondary technology for other treatments.
	Surface barriers	RCRA Subtitle C cover	Technically implementable
		Concrete-based cover	Technically implementable
		Conventional asphalt cover	Technically implementable
		MatCon asphalt	Technically implementable
		Flexible membrane	Technically implementable
	Subsurface horizontal barriers	Freeze walls	Technically implementable
		Permeation grouting	Not technically implementable
		Soil fracturing	Technical implementability uncertain-field demonstration required



**Table 2.3. Results of Technology Identification and Screening (Continued)**

<b>Treatment</b>	<b>Technology Type</b>	<b>Process Options</b>	<b>Screening Comments<sup>a</sup></b>
	Subsurface vertical barriers	Slurry walls	Technically implementable
		Sheet pilings	Technically implementable
	Subsurface vertical barriers Biological	Permeable reactive barrier	Technically implementable
		Anaerobic reductive dechlorination- <i>in situ</i>	Technically implementable
		Aerobic cooxidation- <i>in situ</i>	Technically implementable
	Physical/Chemical	Phytoremediation- <i>in situ</i>	Not technically implementable due to depth of VOC contamination
		Soil vapor extraction- <i>in situ</i>	Technically implementable
		Air sparging- <i>in situ</i>	Technically implementable
	Physical/Chemical Thermal	Soil flushing- <i>in situ</i>	Technically implementable
		Electrokinetics- <i>in situ</i>	Technically implementable
		Air stripping- <i>ex situ</i>	Technically implementable
		Ion exchange- <i>ex situ</i>	Technically implementable
		Granular activated carbon- <i>ex situ</i>	Technically implementable
		Vapor condensation	Technical implementability uncertain
		Soil fracturing- <i>in situ</i>	Technical implementability uncertain
		Soil mixing- <i>in situ</i>	Technically implementable
		Jet grouting- <i>in situ</i>	Not technically implementable
		Liquid atomized injection- <i>in situ</i>	Technically implementable
		Catalytic oxidation- <i>ex situ</i>	Technically implementable
		Electrical resistance heating- <i>in situ</i>	Technically implementable
		Thermal Chemical	Thermal desorption- <i>ex situ</i>
	Steam stripping- <i>in situ</i>		Technically implementable
	Permanganate- <i>in situ</i>		Technically implementable
Fenton's reagent- <i>in situ</i>	Technically implementable		
Chemical	ZVI- <i>in situ</i>	Technically implementable	
	Ozonation- <i>in situ</i>	Technically implementable	
	Persulfate- <i>in situ</i>	Technically implementable	
Chemical (continued)	Redox manipulation- <i>in situ</i>	Technically implementable	
<b>Disposal</b>	Land disposal	Off-site permitted commercial disposal facility	Technically implementable
		NTS	Technically implementable
		PGDP C-746-U Landfill	Technically implementable
	Discharge to groundwater	Within area of contamination after treatment	Technically implementable
	Discharge to surface water	Outfall after treatment	Technically implementable

<sup>a</sup>Gray shading indicates that the technology was screened out as not applicable or not technically implementable.

ZVI = zero-valent iron

### **2.3.5 Containment**

Containment isolates contaminated media from release mechanisms, transport pathways, and exposure routes using surface and/or subsurface barriers, thereby reducing contaminant flux and reducing or eliminating exposures to receptors. Containment alone does not reduce the volume or toxicity of the contaminant source. Containment alone would not meet RAO #1, but could be an effective component of an overall alternative incorporating treatment and/or removal of PTW.

### **2.3.6 Treatment**

Treatment reduces the toxicity, mobility, or volume of contaminants or contaminated media. Contaminant sources may be reduced or eliminated, and contaminant migration pathways and exposure routes may be eliminated. *In situ* methods treat contaminants and media in place without removal. *Ex situ* methods treat contaminants or media after removal.

### **2.3.7 Disposal**

Disposal may include land disposal of solid wastes or discharge of liquid or vapor phase effluents generated during waste treatment processes.

## **2.4 IDENTIFICATION AND SCREENING OF TECHNOLOGY TYPES AND PROCESS OPTIONS**

This section identifies remedial technologies and process options that potentially may meet the RAOs, and provides a preliminary screening based on implementability. The technologies are described and the potential effectiveness in meeting the RAOs and the technical implementability in the UCRS are discussed. Performance data are cited and discussed, and limitations and data needs are identified, as applicable.

The results of the technology screening are detailed in the following text and in Table A.1 (see Appendix A) and are summarized in Table 2.3. Technologies and process options that pass the preliminary screening are evaluated further in Section 2.4.2, based on effectiveness and relative cost. RPOs that will be used to develop the remedial alternatives are selected in Section 2.4.3.

### **2.4.1 Identification and Screening of Technologies**

Each GRA, technology type, and process option listed in Table 2.3 is discussed in the following subsections.

#### **2.4.1.1 LUCs**

LUCs include administrative restrictions on activities allowed on a property. The existing E/PP program and warning signs, discussed below, are interim LUCs intended to achieve RAOs 2a and 2b.

E/PP program—The E/PP program is an interim LUC administered by DOE's contractors at PGDP and currently includes a specific permitting procedure (PAD-ENG-0026) designed to provide a common system to identify and control potential personnel hazards related to trenching, excavation, and penetration. The E/PPs are issued by the Paducah Site's DOE Prime Contractor. The primary objective of the E/PP procedure is to provide notice to the organization requesting a permit of existing underground utility lines and/or other structures and/or any residual contamination to ensure that any E/PP activity is

conducted safely and in accordance with all environmental compliance requirements pertinent to the area (DOE 2008).

The E/PP procedure

- Requires formal authorization (i.e., internal permits/approvals) before beginning any intrusive activities at PGDP;
- Is reviewed annually; and
- Is implemented by trained personnel knowledgeable in its requirements.

An initial draft of an E/PP is reviewed by project support groups to ensure that the latest updates in engineering drawings, utility drawings, and SWMU inventories are considered prior to the issuance of an E/PP.

Warning signs at the units will provide a continuous mechanism for communicating to potential trespassers as well as to workers that danger exists due to the presence of environmental contaminants. In the case of the Southwest Plume sources, the signs would be posted for the source areas and indicate that exposure to contaminated groundwater and soils is possible. Warning signs would be utilized as interim LUCs at the Southwest Plume source areas for residual VOC and non-VOC contamination, pending remedy selection as part of subsequent OUs that addresses relevant media.

#### **2.4.1.2 Monitoring Technologies**

Monitoring may be used in combination with other technologies to meet RAOs. Monitoring for the Oil Landfarm and the C-720 Northeast and Southeast Sites could include initial determination of the extent of VOC contamination, determination of soil contaminant concentrations during excavation, post-remedial action monitoring to determine attainment of RAOs, and long-term post-remedial action compliance monitoring. Monitoring for VOCs including DNAPL in soil and groundwater is discussed below.

Soil Monitoring. Soil monitoring may be used before, during, and after remediation to determine extent and concentrations of VOCs. Soil monitoring technologies potentially applicable to the Southwest Plume source areas are discussed below.

Soil Cores. Collection of soil cores and laboratory analysis for VOCs may be used to identify the extent and distribution of contamination and areas of TCE DNAPL residual saturation. Continuous soil cores may be obtained using DPT, hollow-stem auger or other drilling methods, and TCE extracted and measured using gas chromatography-mass spectrometry (GC-MS) or gas chromatography-electron capture detector. Measured TCE concentrations may be compared to threshold values [e.g., 1% by weight (10,000 mg/kg)] as indirect evidence of presence of DNAPL. The following are other actions that can be taken to improve the overall precision of coring methods for locating chlorinated solvent DNAPL (Kram *et al.* 2001).

- Samples can be immediately immersed in methanol to inhibit the amount of volatilization due to handling and transport.
- Samples can be subject to field “shake tests” in which density differences between the relatively heavier DNAPL and water are qualitatively identified.

- Samples can be exposed to ultraviolet fluorescence with a portable meter to qualitatively identify potential fluorophores in an oil phase.
- Sudan IV or Oil Red O dye can be added to samples; these turn orange-red in the presence of nonaqueous-phase liquid (NAPL) to qualitatively identify separate phases.
- Soil vapors and cutting fluids generated while drilling can be analyzed.
- Soils, fluids, and vapors within a cavity or along a trenched wall of a test pit can be analyzed.
- A small amount of soil or water can be placed in a container that is immediately sealed, equilibrated, and a sample of the vapors that have partitioned into the headspace portion in the container can be analyzed per EPA Method 5021.

This technology is effective, technically implementable, and commercially available and is retained for further evaluation.

Membrane interface probe. The MIP technology was described in the Southwest Plume SI (DOE 2007) and the following discussion is taken from that report. The MIP is used for real-time VOC profiling and sampling. MIP sampling uses a heating element and gas permeable membrane. The element heats the material surrounding the probe, causing the VOCs contained in the material to vaporize. Vapors enter the probe through a gas permeable membrane and are transported through tubing to the surface by an inert carrier gas. The sample then is analyzed in the field with equipment appropriate to the needs of the investigation.

A photoionization detector (PID) is used for detection of VOCs, and an electron capture detector (ECD) is used for quantitation. When quantitative analysis of individual VOC species is needed, the surface analytical equipment consists of a GC-MS, direct sampling ion-trap mass spectrometer, or photo-acoustic analyzer.

This technology is effective, technically implementable using DPT, commercially available, and is retained for further evaluation.

Soil Vapor Sampling. Soil vapor sampling may be used to determine concentrations of VOCs in soil air-filled pore space, and thereby indirectly determine the presence and extent of DNAPL TCE. Drive points connected to plastic or stainless steel tubing are driven or pushed to the desired depth and soil vapor extracted and either containerized for later analysis or analyzed directly using GC-MS, ECD, or PID. This technology is effective and commercially available, but only technically implementable in the unsaturated zone. This technology is retained for further evaluation.

Soil Moisture Monitoring and Sampling. Soil moisture monitoring may be used to monitor the effectiveness of technologies aimed at restricting infiltration of water (e.g., capping). Soil moisture monitoring devices, including tensiometers and time domain reflectometry arrays, may be installed in the soil column and moisture content and soil matrix potential monitored. These soil moisture data may be used to assess the effects of capping on mitigating infiltration and contaminant transport.

Neutron probe devices may be used to measure soil moisture in the subsurface through aluminum access tubes. The tubes are driven to the desired depth and neutron probes lowered into the tubes. Neutrons emitted by a 241-Americium source in the detector are attenuated by water, providing an *in situ* measurement of the soil moisture content. The detector signal is transmitted to a data recorder at the surface and the soil moisture content determined relative to a calibration standard.

Soil moisture sampling using suction lysimeters may be used to determine dissolved-phase concentrations of TCE and its degradation products in soil pore water and thereby progress toward attainment of RAOs. Porous cups attached to plastic tubing are installed in silica flour in drilled or driven boreholes. Vacuum is applied to tubing causing water to flow into the porous cup. After water has collected in the cup, the vacuum is released and positive pressure is applied. The collected water then flows up a second length of tubing to a collection vessel at the surface and analyzed using GC-MS, ECD, or PID.

Soil moisture monitoring and sampling technologies are effective, technically implementable in the unsaturated zone, and commercially available. These technologies are retained for further evaluation.

Gore-Sorbers®. Passive soil gas collectors including Gore-Sorbers may be used to determine the nature of contamination. The Gore-Sorber® module is a passive soil gas sampler that consists of several separate sorbent collection units called sorbers (EPA 1998b). Each sorber contains sorbent materials selected for their broad range of VOCs and SVOCs and for their hydrophobic characteristics. The sorbers are sheathed in a vapor permeable insertion and retrieval cord constructed of inert, hydrophobic material that allows vapors to move freely across the membrane and onto the sorbent material and protects the granular adsorbents from physical contact with soil particulates and water.

The Gore-Sorber® module is installed to a depth of 0.61 to 0.91 m (2 to 3 ft). A pilot hole is created using a slide hammer and tile probe or hand drill (in paved areas). The sampler then is manually inserted into the hole using push rods. The module is left in place for about 10 days, retrieved by hand, and must be analyzed by the developer.

This technology is effective, technically implementable, commercially available, and is retained for further evaluation.

Raman Spectroscopy. Raman spectroscopy relies on the detection of light wavelength shifts from compounds of interest and is capable of direct identification of several chlorinated DNAPL constituents (Kram *et al.* 2001). Raman spectroscopy is used to detect light scattered from incident radiation, typically from a laser.

A Raman device has been coupled to a cone penetrometer platform and successfully used to identify subsurface DNAPL constituents by their unique spectral signatures at the Savannah River Site in Aiken, South Carolina. Although confirmation samples are not required to verify a Raman detection of DNAPL, the Raman technique may require a threshold mass fraction of DNAPL for detection. As with other strategies, confirmation samples are advised.

This technology is potentially effective for DNAPL TCE detection, technically implementable, and is commercially available. This technology is retained for further consideration.

Groundwater Monitoring. Groundwater monitoring may be used in the UCRS or RGA saturated zones before, during, and after remediation to determine extent and concentrations of VOCs. Monitoring technologies potentially applicable to groundwater in the Oil Landfarm and the C-720 Northeast and Southeast Sites are discussed below.

Sampling and Analysis. Conventional groundwater sampling consists of withdrawing a representative sample of groundwater from a well or drive point, using a variety of pump types or bailers, and analyzing the contents either on-site or in a fixed-base laboratory. This technology is widely used for compliance monitoring and is effective, technically implementable, and commercially available. This technology is retained for further evaluation.

Partitioning Interwell Tracer Test. The Partitioning Interwell Tracer Test (PITT) was discussed in the Innovative Technology Report (Hightower *et al.* 2001) and this discussion is taken from that source. The PITT is a proprietary technology marketed by Duke Engineering and Services that can be used prior to surfactant flushing to assess DNAPL volumes. The PITT uses injection of surfactant mixtures and numerical analysis of recovery proportions to measure the volume and describe the spatial distribution of subsurface DNAPL contamination zones. The PITT may be used in both the vadose and saturated zones, and reportedly can locate low-volume quantities [3.78 liters (1 gal)] of DNAPL.

At Paducah, the technology has most application in the RGA, due to heterogeneity and low well yields in the UCRS. The cost of the technology is high relative to other monitoring technologies. The effectiveness and technical implementability of this technology for monitoring of DNAPL TCE in the UCRS are low; therefore, this technology is screened from further consideration.

Diffusion Bags. Diffusion bags are passive groundwater sampling devices that can be hung in wells to collect VOCs or other soluble contaminants (ITRC 2002). Semipermeable diffusion bags containing deionized water are allowed to equilibrate with surrounding groundwater and eventually reach the same concentrations of soluble constituents. Diffusion bags can avoid some of the problems associated with obtaining representative groundwater samples using conventional methods and are useful in vertical profiling of contaminant distributions. Diffusion bags may be used in plume mapping and compliance monitoring. This technology is effective, technically implementable, commercially available, and is retained for further evaluation.

Borehole Fluxmeter. The passive fluxmeter (PFM) is an innovative and emerging technology that measures subsurface water and contaminant flux directly (DOD 2007). This technology can be used for process control, remedial action performance assessments, and compliance monitoring. This technology may be used to directly measure contaminant flux (i.e., mass flow rate) from NAPL areas. When deployed in a well, groundwater flows through the PFM under natural gradient conditions. The interior composition of the PFM is a matrix of hydrophobic and hydrophilic permeable sorbents that retain dissolved organic and/or inorganic contaminants present in fluid intercepted by the unit. The sorbent matrix is also impregnated with known amounts of one or more fluid soluble resident tracers, which are leached from the sorbent at rates proportional to fluid flux.

After a specified period of exposure to groundwater flow, the PFM is removed from the well or boring. Next, the sorbent is carefully extracted to quantify the masses of all contaminants intercepted by the PFM and the residual masses of all resident tracers. Contaminant masses are used to calculate cumulative time-averaged contaminant mass fluxes, while residual resident tracer masses are used to calculate cumulative or time-average groundwater fluxes.

Borehole fluxmeters have been tested in wells to depths of 60 m (196.85 ft). This technology is potentially effective for compliance monitoring for DNAPL cleanup, is technically implementable in the UCRS and RGA, and commercially available. This technology is retained for further consideration.

Ribbon NAPL Sampler. The Ribbon NAPL Sampler (RNS) is a direct sampling device that provides detailed depth discrete mapping of DNAPLs in a borehole (Riha *et al.* 1999). This qualitative method is used to complement other techniques. The RNS has been deployed in the unsaturated and saturated zones and uses the Flexible Liner Underground Technologies, Ltd. (FLUTE), membrane system (patent pending) to deploy a hydrophobic absorbent ribbon in the subsurface. The system is pressurized against the wall of the borehole and the ribbon absorbs any NAPL that it contacts.

This technology is potentially effective for DNAPL TCE detection, technically implementable, and is commercially available. The usability of this technology in unconsolidated sediments is uncertain; however, this technology is retained for further consideration.

DNAPL Interface Probe. The DNAPL interface probe incorporates an infrared sensor and a conductivity sensor attached to a coaxial cable. The cable is mounted on a spool, allowing the probe to be lowered into a groundwater MW. The probe emits an audible signal upon detection of differences in electrical conductivity and infrared response that occurs when the probe passes through the interface between water and an organic liquid. The cable is marked with depth graduations, allowing the operator to determine and record the well depths at which DNAPL occurs.

This technology is potentially effective for DNAPL TCE detection, technically implementable, and is commercially available. This technology is retained for further consideration.

### **2.4.1.3 Monitored Natural Attenuation/Enhanced Attenuation**

EPA defines MNA as (OSWER Directive 9200.4-17, 1997): "...reliance on natural attenuation processes (within the context of a carefully controlled and monitored clean-up approach) to achieve site-specific remedial objectives within a time frame that is reasonable compared to other methods. The 'natural attenuation processes' that are at work in such a remediation approach include a variety of physical, chemical, or biological processes that, under favorable conditions, act without human intervention to reduce the mass, toxicity, mobility, volume, or concentration of contaminants in soil and groundwater. These *in situ* processes include biodegradation, dispersion, dilution, sorption, volatilization, and chemical or biological stabilization, transformation, or destruction of contaminants" (EPA 1998b).

MNA is appropriate as a remedial approach only when it can be demonstrated capable of achieving a site's remedial objectives within a time frame that is reasonable compared to that offered by other methods and where it meets the applicable remedy selection program for a particular OSWER program. EPA expects that MNA typically will be used in conjunction with active remediation measures (e.g., source control), or as a follow-up to active remediation measures that already have been implemented (EPA 1998b).

Each natural attenuation process occurs under a range of conditions that must be extensively characterized and monitored over time to determine the effectiveness of the remedy. The extent of sorption of VOCs in the UCRS and RGA at PGDP has been estimated using the organic carbon fraction of the geologic media and the  $K_{oc}$  of the individual VOCs to calculate partition coefficients. Aerobic biodegradation of TCE has been demonstrated to occur in the RGA (KRCEE 2008), and determination of rates and extents in the UCRS are ongoing. Abiotic degradation has not been verified.

Natural attenuation alone is not expected to remediate DNAPLs (EPA 1999a). Application of this technology in conjunction with source treatment, removal, containment or control potentially may be a cost-effective strategy.

Data needs for MNA are detailed in EPA 1998b and 1999a and include these:

- Soil and groundwater quality data
  - Three-dimensional distribution of residual-, free-, and dissolved-phase contaminants
  - Historical water quality data showing variations in contaminant concentrations through time
  - Chemical and physical characteristics of the contaminants
  - Geochemical data to assess the potential for biodegradation of the contaminants

- Location of potential receptors
  - Groundwater wells
  - Surface water discharge points

This technology is technically implementable and commercially available and is retained for further evaluation as a secondary technology.

#### **2.4.1.4 Removal technologies**

Removal, in the context of this FFS, is the excavation of UCRS soils contaminated with VOCs. Complete removal of VOCs present at the Oil Landfarm and the C-720 Northeast and Southeast Sites would require excavation to approximately 60 ft bgs. The technical complexity of excavation increases greatly with depths greater than about 20 ft (6m) (Terzaghi *et al.* 1996), and factors including slope stability, control of seepage, worker safety, management of excavated soil, shoring requirements, potential for mobilization of DNAPL, and others must be considered.

Deep excavations require extensive terracing or elaborate shoring. Piping of groundwater and entry of heaving sands into the excavation can occur and may pose complications as excavation proceeds below the water table. Excavation of the Oil Landfarm would require the largest volume of excavated soil, but likely would be less complex than excavating at the C-720 Area Southeast site, due to the proximity to the building and the associated surface loading applied by the building to the slopes or sides of the excavation, as well as the potential for damage to the building foundation and subsurface infrastructure. Excavation at the C-720 Area sites would be most feasible after the ongoing maintenance and support functions have ceased and the building has been transferred to the Decontamination and Decommissioning (D&D) OU. Currently, no date for D&D of the C-720 Building has been identified.

Ground pressure and vibration caused by construction and some drilling technologies have been observed to induce coalescing and movement of DNAPL (Payne *et al.* 2008). Downward DNAPL movement beneath an excavation could not be effectively contained and could result in migration to the RGA.

Excavation can have a large capital cost, but no O&M costs, and may have the largest probability of achieving over 99% DNAPL removal at smaller sites with contamination restricted to the upper 12.2 m (40 ft) of the soil (AFCEE 2000). Overall, experience has shown that excavation works best and is most cost-competitive at sites where confining layers are shallow, soil permeabilities are low, the volume of source materials is less than 5,000 m<sup>3</sup> (176,600 ft<sup>3</sup>), and the contaminants do not require complex treatment or disposal (NRC 2004). These optimal conditions are not present at the Southwest Plume source area sites. Several types of excavation equipment that potentially could be used at the Southwest Plume sites are discussed below.

Backhoes, trackhoes, and front-end loaders can do an effective job of removing contaminated soil and overburden. Practical considerations regarding equipment limitations and sidewall stability can restrict the depth of excavation to a maximum of about 7.62 to 9.14 m (25 to 30 ft) in a single lift. Where source zone contamination lies at greater depth, excavation can require a series of progressively deeper lifts or terraces, accessed by ramps. This technique can extend the maximum depth of excavation in unconsolidated soil to over 12.2 m (40 ft); however, the unit cost of soil excavation increases rapidly with increasing depth of excavation. Additionally, implementation of methods to control or prevent the movement of groundwater into the excavation may be required if source removal extends below the water table. These methods are expensive and can require placement of caissons or driven sheet piling and dewatering (AFCEE 2000).



Vacuum excavation can be used to remove contaminated soil to depths of 10.67+ m (35+ ft) in congested areas where access, obstructions, and buried utilities prevent safe operation of conventional excavators. A combination of high-pressure air (or water) is used to break up the soil, while a high flow vacuum removes the soil and deposits it in the vacuum truck collector body. Vacuum trucks are commercially available with capacities up to 15 yd<sup>3</sup>. Additionally, contaminated soil and sludge can be placed directly in vacuum roll-off boxes (20 or 25 yd<sup>3</sup>) or bags for disposal without having to decontaminate the vacuum truck (Heritage Environmental Services, Indianapolis, IN).

Effective excavation can be performed as far as 91.44 m (300 ft) from the vacuum truck, allowing work inside buildings and in highly congested areas. The high-flow vacuum eliminates the need for additional dust control measures typically required during conventional excavation activities (T-Rex Services, Houston, TX). This technology is technically implementable and commercially available and is retained for further evaluation.

Cranes and clamshells often are used in deep excavations (e.g., excavation of piers, dredging, and mining). Excavation at depths of over 100 ft are achievable.

This technology is potentially effective, technically implementable, commercially available, and is retained for further evaluation.

Large Diameter Augers (LDAs) can be used to effectively remove contaminated soil using a drill rig equipped with a large diameter (3 ft to 10 ft) solid stem auger. LDA borings can reach depths of 27.4 m (90 ft) depending on the lithology and drill rig. Following excavation, holes typically are filled with flowable fill material. Conventionally, LDAs are used for source removal where standard heavy equipment is not feasible (e.g., heavily industrialized sites and/or deep contamination). However, densely located subsurface utilities could potentially impact the boring spacing, and, therefore, the removal efficiency of this technology. The effectiveness of this technology partially depends on the location and spacing of the borings. The boring overlap pattern can be designed to achieve 100% removal; however, due to the amount of fill material excavated by overlapping the borings, the cost of excavation increases with the percentage of boring overlap. This technology is technically implementable at the Oil Landfarm and commercially available and is retained for further evaluation.

#### **2.4.1.5 Containment technologies**

Containment technologies may isolate source areas, reduce infiltration, and thereby minimize VOC migration to the RGA. Surface barriers potentially could meet RAO #3 by reducing or eliminating recharge through the DNAPL areas, thereby reducing the driving force for TCE flux from the UCRS to the RGA. Containment technologies alone would not meet RAO #1, but could be an effective component of an overall alternative incorporating treatment and/or removal of PTW.

Infiltrating precipitation and anthropogenic water recharge to the UCRS provide the driving force for transport of VOCs from source areas to the RGA. Surface barriers and/or recharge controls are designed to reduce or eliminate surface recharge, thereby eliminating the driving force. Subsurface barriers may reduce or eliminate flux of TCE in infiltrating water beyond the contaminated intervals. Containment technologies are summarized below and screened in Table A.1 (see Appendix A).

#### **2.4.1.6 Hydraulic Containment**

Recharge Controls. Recharge controls could reduce facility process water discharges to the UCRS, promote surface water run-off, and reduce recharge of the UCRS in the Southwest Plume TCE source areas, thereby limiting leaching of VOCs from source areas and migration to the RGA. Recharge control

options are technically implementable at present using commercially available materials and equipment. Potential recharge control options include the following:

- Identifying saturated zones in the UCRS based on past investigations and determining sources;
- Installing rain gutters on the C-720 Building and other adjacent facility roofs and directing the water away from source areas or to storm drains;
- Routing runoff from roofs, roads, and asphalt parking areas to lined ditches or storm drains;
- Eliminating surface water drainage from adjacent areas onto source areas;
- Lining ditches and culverts in the vicinity of the Oil Landfarm and the C-720 Northeast and Southeast Sites with concrete or membranes;
- Inspecting and repairing, as needed, asphalt areas to promote runoff and minimize infiltration;
- Inspection, clearing, and repairing, as needed, discharge pipes, culverts, and storm drains;
- Inspecting, metering, and repairing water lines in the vicinity of the Oil Landfarm and the C-720 Northeast and Southeast Sites as needed; and
- Eliminating all French drains, condensate discharge, or other sources of water to the subsurface in the vicinity of the Oil Landfarm and the C-720 Northeast and Southeast Sites.

This approach is effective, technically implementable, and commercially available, and is retained for further evaluation.

Groundwater Extraction. Groundwater pumping may be used to contain dissolved-phase contaminant plumes or may be used as a secondary technology to circulate or contain treatment amendments. Groundwater yields from wells completed in the UCRS are insufficient for sustainable pumping or for containment at the Oil Landfarm and the C-720 Northeast and Southeast Sites, which constrains the effectiveness and technical implementability of technologies that rely on groundwater pumping or circulation for removal or treatment of contaminants. Groundwater pumping is not effective for DNAPL recovery except as a secondary technology.

Pumping of RGA groundwater may be required for containment during *in situ* treatment of DNAPL TCE in the UCRS (e.g., surfactant flooding). Groundwater pumping is effective as a secondary process for other primary technologies, technically implementable, commercially available, and is retained for further evaluation.

**Surface Barriers.** Surface barriers reduce recharge of precipitation and/or anthropogenic water to the subsurface, thereby reducing the driving force for infiltration and leaching of VOCs from source areas. As soil moisture levels decrease in response to reduction in recharge, the unsaturated hydraulic conductivity of soils also decreases, resulting in reduction of contaminant flux rates.

EPA (2008a) identifies the following advantages and limitations of surface barriers for containment of source areas.

- Advantages of containment

- It is a simple and robust technology.
  - Containment typically is inexpensive compared to treatment, especially for large source areas.
  - A well-constructed containment system almost completely eliminates contaminant transport to other areas and thus prevents both direct and indirect exposures.
  - In unconsolidated soils, containment systems substantially reduce mass flux and source migration potential.
  - Containment systems can be combined with *in situ* treatment and, in some cases, might allow the use of treatments that would constitute too great a risk with respect to migration of either contaminants or reagents in an uncontrolled setting.
- Limitations of containment
    - Containment does not reduce source zone mass, concentration, or toxicity unless it is used in combination with treatment technologies.
    - Containment systems such as slurry walls have limitations on how long they are effective, and thus, provide containment only over a finite period.
    - Data are not yet available concerning the long-term integrity of the different types of physical containment systems.
    - Long-term monitoring of the containment system is essential for ensuring that contaminants are not migrating.

Surface barriers are commonly used to improve performance of soil vapor extraction (SVE) systems by reducing airflow from the surface and forcing flow through the contaminated soil intervals. Construction at the C-720 Northeast and Southeast Sites would be constrained by surface and subsurface infrastructure. Asphalt, concrete, and geosynthetic covers have been installed and sealed around infrastructure; however, compacted clay layers cannot be as readily installed over or around surface infrastructure. Several types of surface barriers are discussed here.

RCRA Subtitle C Cover. This type of cover is designed to meet performance objectives for RCRA Subtitle C landfill closures under 40 *CFR* § 264.310. EPA guidance (EPA 1987) recommends a cover consisting of (top to bottom) an upper vegetated soil layer, a sand drainage layer, and a flexible membrane liner overlying a compacted clay barrier. A gas collection layer may be included if gas-generating wastes are capped. Nominal thickness of this type of cover is 1.5 m (4.9 ft), and addition of grading fill would increase the thickness at the crest.

This type of cover is designed to be less permeable than the bottom liner of a RCRA Subtitle C landfill and meets the requirements of 40 *CFR* § 264.310. Other types of covers may be used if equivalent performance can be demonstrated through numerical modeling and/or site-specific water balance studies.

A RCRA Subtitle C cover potentially could meet RAO #3 by reducing recharge through VOC source areas. This type of cover is potentially effective, technically implementable, commercially available, and is retained for further consideration.

Concrete and Asphalt-based Covers. Concrete and asphalt cover systems may consist of a single layer of bituminous or concrete pavement over a prepared subgrade to isolate contaminated soils, reduce infiltration, and provide a trafficable surface.

An asphalt cover would be technically implementable at Oil Landfarm and the C-720 Northeast and Southeast Sites at present. The asphalt surface can be sealed around infrastructure using adhesive sealants and flexible boots; however, constructability is improved by absence of surface infrastructure.

MatCon™ asphalt has been used for RCRA Subtitle C-equivalent closures of landfills and soil contamination sites. MatCon™ is produced using a mixture of a proprietary binder and a specified aggregate in a conventional hot-mix asphalt plant. The EPA Superfund Innovative Technology Evaluation program evaluated MatCon™ in 2003 (EPA 2003) with respect to permeability, flexural strength, durability, and cost. EPA determined that the as-built permeability of  $<1E-07$  cm/s was retained for at least 10 years with only minor maintenance and that MatCon™ had superior mechanical strength properties and durability. This technology is effective, technically implementable, commercially available, and is retained for further evaluation.

Flexible Membranes. Flexible membranes are single layers of relatively impermeable polymeric plastic [high-density polyethylene and others]. Flexible membranes are a component of a RCRA Subtitle C cover and, potentially, of other types and also may be used alone. Flexible membranes are laid out in rolls or panels and welded together. The resulting membrane cover essentially is impermeable to transmission of water unless breached. Flexible membranes can be sealed around infrastructure using adhesive sealants and flexible boots; however, constructability is improved by absence of surface infrastructure.

Flexible membranes must be protected from damage to remain impermeable. Flexible membranes are subject to damage and/or leakage due to puncturing or abrasion, exposure to excessive heat, freezing, temperature cycling, poor welds, tearing, shearing, UV or other radiation exposure, and chemical incompatibilities. This technology is effective, technically implementable, commercially available, and is retained for further evaluation.

**Subsurface Horizontal Barriers.** Subsurface horizontal (hydrologic) barriers may potentially limit downward migration of contaminants in infiltrating water by formation of a physical barrier to flow. Subsurface hydrologic barriers must be co-implemented with surface hydrologic barriers to avoid accumulation of infiltrating water on the subsurface barrier, potentially resulting in the creation of perched zones of saturation and eventual degradation of the containment barrier due to increased vertical and lateral hydraulic gradients. Several types of subsurface barriers are discussed below.

Freeze Walls. Frozen barrier walls, also called cryogenic barriers or freeze walls, are constructed by artificially freezing the soil pore water, resulting in decreased permeability and formation of a low-permeability barrier. The frozen soil remains relatively impermeable and migration of contaminants thereby is reduced. This technology has been used for groundwater control and soil stabilization in the construction industry and for strengthening walls at excavation sites for many years. This technology also has been identified for contamination and dust control during excavation of buried wastes.

Implementation of this technology requires installing pipes called thermoprobes into the ground and circulating refrigerant through them. As the refrigerant moves through the system, it removes heat from the soil and freezes the pore water. Systems can be operated actively or passively depending on air temperatures (EPA 1999b).

The thermoprobes can be placed at 45-degree angles along the sides of the area to be contained to form a V-shaped or conical barrier to provide subsurface containment. This technology is considered innovative

and emerging for remediation, but is commercially available through the geotechnical construction industry.

Freeze wall containment could potentially eliminate TCE flux as long as the soil remains frozen, and would therefore be effective only as a temporary containment measure. This technology is potentially effective, technically implementable, commercially available, and is retained for further evaluation.

Permeation Grout Barriers. Permeation grouting has been used extensively in construction and mining to stabilize soils and control movement of water. Low-viscosity grout is injected vertically or directionally at multiple locations into soil at sufficiently low pressure to avoid hydrofracturing while filling soil voids. Soil permeability may be reduced with minimal increase in soil volume using this method (EPA 1999b).

The extent of grout permeation is a function of the grout viscosity, grout particle size, and soil and particle size distribution. A variety of materials can be used in permeation grouting, and it is essential to select a grout that is compatible with the soil matrix. Particulate grouts are applicable when the soil permeability is greater than  $1\text{E-}01$  cm/s. Chemical grouts can be used with soil permeabilities greater than  $1\text{E-}03$  cm/s (EPA 1999b). Permeation grouting has been tested at pilot scale, resulting in formation of subsurface layers of inconsistent coverage, thickness, and permeability.

Viscous liquid barriers are a variant of permeation grouting using low-viscosity liquids that gel after injection, forming an inert impermeable barrier. Field tests have resulted in formation of subsurface layers of inconsistent coverage, thickness, and permeability.

Permeation grouting is limited to soil formations with moderate to high permeabilities. Establishing and verifying a continuous, effective subsurface barrier is difficult or impossible in heterogeneous soils or in the presence of subsurface infrastructure.

Permeation grouting is likely not technically implementable at the Oil Landfarm and the C-720 Northeast and Southeast Sites due to low saturated hydraulic conductivity in zones containing VOCs, and heterogeneous soils. This technology therefore is screened from further consideration.

Soil Fracturing. Soil fracturing may be accomplished either pneumatically, using air, or hydraulically, using liquids. Pneumatic fracturing involves the injection of highly pressurized gas (nitrogen or air) into the soil via borings to extend existing fractures and create a secondary network of subsurface channels. Hydraulic fracturing (hydrofracturing) uses water or slurry instead of gas. Soil fracturing can extend the range of treatment when combined with other primary technologies such as bioremediation, chemical oxidation/reduction or SVE. Soil fracturing for these uses is discussed as a secondary technology in the discussion of the primary technology.

The horizontal subsurface barrier technology involves fracturing the soil matrix by creating stress points over a broad area (EPA 1999a). Soil tends to preferentially fracture along the horizontal plane. Air is injected into the boreholes at increasing pressures to cause the soil to fracture. After soil fracture formation, grouts or polymers can be injected into the fracture in an effort to create a low-permeability horizontal barrier. This technology was successfully demonstrated at pilot scale at the Savannah River Site, Aiken, SC, in 1996. Excavation of the test site showed the barrier to be continuous with a total diameter of 4.9 m (16 ft). This technique may also be used to create horizontal reactive barriers or to distribute chemical treatment amendments.

Fracturing potentially may mobilize NAPLs (ARS 2009). Recovery systems capable of capturing mobilized NAPL (i.e., SVE or multiphase recovery), are necessary to ensure NAPL containment during fracturing.

Pneumatic and hydraulic fracturing was evaluated in Hightower *et al.* (2001) and KRCEE (2005) as an adjunct technology for *in situ* chemical oxidation (ISCO) and SVE at PGDP DNAPL sites and was recommended for field testing. This technology is potentially implementable, but would require an on-site demonstration to determine feasibility and effectiveness. This technology is retained for further consideration.

**Subsurface Vertical Barriers.** Vertical barrier technologies can be used to isolate areas of soil contamination and to restrict groundwater flow into the contaminated area or underlying zones. Subsurface vertical barriers may be used to contain or divert contaminated groundwater flow. Subsurface vertical barrier technologies must be “keyed” into an underlying low permeability layer to avoid leakage around the barrier if complete containment is required (Deuren *et al.* 2002).

Given that flow is predominantly vertically downward through the UCRS at the Oil Landfarm and the C-720 Northeast and Southeast Sites, and that no low permeability layer exists between the VOC source areas and the RGA, vertical barriers are likely effective only as adjunct technologies for other primary technologies (e.g., removal or *in situ* treatment). The following is a discussion of several different types of subsurface vertical barriers.

Slurry Walls. Slurry walls are an established and commercially available technology. Slurry walls consist of vertically excavated trenches that are kept open by filling the trench with a low permeability slurry, generally bentonite and water. The slurry forms a very thin layer of fully hydrated bentonite that is impermeable. Soil (often excavated material) then is mixed with bentonite and water to create a soil-bentonite backfill with a hydraulic conductivity of approximately 1E-07 cm/s, which is used to backfill the trench, displacing the slurry. Trench excavation is commonly completed by a backhoe or a modified boom at depths of up to 18.3 m (60 ft). A drag line or clam shell may be used for excavations greater than 18.3 m (60 ft).

Alternatively, a cement, bentonite, and water slurry that is left in the trench to harden may be used. Concrete slurry walls may have a greater hydraulic conductivity than traditional slurry walls and the excavated soil that is not used as a backfill must be disposed of properly. This technology is technically implementable, commercially available, and is retained for further evaluation.

Sheet Piling. Sheet piling are an established and readily available technology. Sheet piling are long structural steel sections with a vertical interlocking system that are driven into the ground to create a continuous subsurface wall. After the sheet piles have been driven to the required depth, they are cut off at the surface. Sheet piling are commonly used in excavations for shoring and to reduce groundwater flow into the excavation and, therefore, are a potentially useful adjunct technology for soil removal. This technology is effective, technically implementable, commercially available, and is retained for further evaluation.

Permeable Reactive Barriers. Permeable reactive barriers (PRBs) are designed and constructed to permit the passage of water while immobilizing or destroying contaminants through the use of various reactive agents. PRBs are often used in conjunction with subsurface vertical barriers, such as sheet piling, to form a funnel and gate system that directs the groundwater flow through the PRB.

PRBs have been shown to be effective for the removal of TCE and specific types are discussed in more detail. Some of these technologies also are evaluated as *in situ* treatments. Vertical PRBs would have the same constraints as other vertical barriers. They are likely effective only as adjunct technologies for other primary technologies (e.g., removal or *in situ* treatment) given that hydraulic gradients in the UCRS source areas are primarily vertically downward, and no continuous confining layer exists to key vertical walls into.

PRBs may be constructed to depths of 18.3 m (60 ft) bgs, but complexity and cost increase with depth (FRTR 2008).

Zero-valent iron (ZVI) is the most common reactive media used in PRBs. Halogenated hydrocarbons, such as TCE, are reductively dehalogenated by the iron, eventually reducing the compound to ethane and ethene that are amenable to biodegradation. The successful use of ZVI PRBs to remediate TCE is well documented and the technology is readily available (Tri-Agency 2002).

Oxidizing and reducing conditions can be generated in the subsurface by applying an electrical potential to permeable electrodes that are closely spaced to form a PRB panel. The electrical potential can be used to induce the sequential reduction of halogenated solvents such as TCE. This technology was shown to reduce TCE flux rates by as much as 95% at the pilot-scale level at the F. E. Warren Air Force Base (Sale *et al.* 2005).

Mulch, when used as a PRB agent, acts as a source of carbon for aerobic bacteria that lowers the dissolved oxygen concentration and creates a redox potential in the barrier. The resulting anaerobic degradation byproducts of the organic mulch, which include hydrogen and acetate, may then be used by anaerobic bacteria to reductively dechlorinate TCE and other chlorinated VOCs. TCE also may be removed from the groundwater passing through the PRB via sorption and other biotic and abiotic processes. This technology was shown to reduce successfully TCE concentrations by 95% over a 2-year period at the Offutt Air Force Base (GSI 2004). This technology is technically implementable, commercially available, and is retained for further evaluation.

#### **2.4.1.7 Treatment technologies**

Treatment technologies may destroy, immobilize, or render contaminants less toxic. Treatment technologies may be implemented *in situ*, *ex situ*, or both. The following are treatment technologies potentially applicable to the Oil Landfarm and the C-720 Northeast and Southeast Sites.

***In situ* Treatment.** *In situ* treatments destroy, remove, or immobilize VOCs without removing or extracting contaminated media. *In situ* treatment technologies may involve distributing fluids or gaseous amendments; applying thermal, pressure, or electrical potential gradients; manipulating subsurface conditions to promote biotic or abiotic contaminant degradation; or applying physical mixing in combination with other treatments. *In situ* treatments potentially applicable to VOCs in the UCRS are discussed below.

**Biological Technologies.** Biodegradation of chlorinated ethenes in the subsurface occurs through one or more of three different pathways, which may occur simultaneously (ITRC 2005).

- (1) The contaminant is used as an electron acceptor and is reduced by the microbe, but not used as a carbon source [i.e., the anaerobic reductive dechlorination (ARD) process].
- (2) The contaminant is used as an electron donor and is oxidized by the microbe, which obtains energy and organic carbon from the contaminant.
- (3) The contaminant is cometabolized; this is a process where an enzyme or other factor used by the microbe for some other purpose fortuitously destroys the contaminant while providing no benefit to the microbe itself. Cooxidation is a form of cometabolism.

Bioremediation acts on dissolved aqueous phase VOCs, and does not act directly on DNAPL. Instead, the technology relies on degradation and solubilization processes that occur near the water-DNAPL interface.

The DNAPL contaminant mass must transfer into the aqueous phase before it can be subjected to the dechlorination or oxidation processes.

Biodegradation of dissolved-phase VOCs in DNAPL zones or VOCs sorbed to solids increases the rate of dissolution by maintaining a relatively high concentration gradient between the DNAPL, or sorbed phase, and the aqueous phase (i.e., maintaining contaminant concentrations in the aqueous phase as low as possible). Significant destruction of contaminant mass in the source area can be achieved by increasing the rate of contaminant dissolution. Even with increased dissolution rates, however, source areas at many sites are expected to persist for many decades, due to the large amount of DNAPL mass present and the difficulty of establishing conditions favorable for biodegradation throughout the contaminated areas. Despite variation in source area characteristics, enhancing the contaminant dissolution rate remains a key process objective for bioremediation of source areas. The following is a discussion of ARD and aerobic cooxidation.

Anaerobic reductive dechlorination. Enhanced anaerobic reductive dechlorination occurs through addition of an organic electron donor and nonindigenous dechlorinating microbes, as necessary, to facilitate the sequential transformation of chlorinated ethenes as follows:



KRCEE (2008) noted that the presence of anaerobic TCE degradation products including *cis*-DCE observed in UCRS groundwater southwest of the C-400 Building and near RGA source areas is indicative of localized areas where ARD processes occur; however, rates and extent of ARD in the UCRS are not quantified.

Conditions favorable to ARD success, based on case studies, include (ITRC 2005) the following:

- Relatively low-strength residual sources characterized by nonaqueous-phase contaminants present primarily at residual saturation levels with no massive DNAPL pools.
- Relatively homogenous and permeable subsurface environment that would facilitate amendment injection and distribution throughout the contaminant zone.
- Sites with relatively long remedial time frames amenable to the achievable rate of contaminant mass destruction.
- Sites with sufficient access to facilitate the required amendment injections.
- Sites with sufficient hydraulic capture and/or downgradient buffer zone to ensure that the treatment effects, such as production of dissolvent metals and/or partial degradation products, such as VC, do not impact potential receptors.
- Sites where cost is a major driver in the technology selection process.

The Southwest Plume conceptual site model as described in Section 1.2.4 includes a favorable DNAPL distribution as residual saturation, with no DNAPL pools. The subsurface in the UCRS is relatively nonhomogenous and measured  $K_{\text{sat}}$  values range from 1.0E-08 to 6.9E-04 cm/s, due to depositional heterogeneities in the clays, sands, silts, and gravels that comprise the formation (DOE 1998a).

Effectiveness and technical implementability of *in situ* bioremediation-anaerobic reductive dechlorination (ISB-ARD) at the PGDP Southwest Plume sites is uncertain due to the heterogeneity and variable extent



of saturation in the UCRS soils, resulting in difficult conditions for injecting and circulating liquid amendments. However, at SWMU 1, the preferential pathway by which the TCE historically migrated to the RGA is expected to be intact—potentially allowing ISB-ARD to occur in these areas even though the matrix materials are heterogeneous. Establishing conditions favorable for ARD also may inhibit ongoing aerobic degradation processes demonstrated to exist in the RGA (KRCEE 2008). The treatment areas would have to be saturated for the process to be implemented. ISB-ARD potentially may be effective as a polishing step after implementation of other primary technologies. Secondary effects may include color, odor, and turbidity for some time after treatment. This technology is technically implementable and commercially available and is retained for further evaluation.

*Aerobic Cometabolism.* TCE is not readily degraded aerobically as a primary substrate, but can be cometabolized. Cometabolism occurs when a microbe using an organic compound as a carbon and energy source produces enzymes that fortuitously degrade a second compound, without deriving energy or carbon for growth from that compound. Microbes and microbial consortia of multiple species using methane as a substrate have been demonstrated to produce methane monooxygenase (MMO), which fortuitously oxidizes TCE. This conversion has been demonstrated to occur naturally in groundwater at many sites and is part of natural attenuation processes. Aerobic cometabolism has been demonstrated to occur in the RGA at the PGDP; however, evidence of cometabolism in the UCRS has not yet been developed (KRCEE 2008).

MMO inserts molecular oxygen into TCE, removing the carbon-carbon double bond, creating TCE epoxide. The epoxide is unstable in the aqueous environment outside the cell and breaks down to formate, chlorinated acids, glyoxylate, and carbon monoxide. Methanotrophs and/or heterotrophs then can metabolize these products into final products of carbon dioxide and cell mass.

Aerobic cooxidation acts only on dissolved aqueous phase VOCs and only indirectly on DNAPL or sorbed phases, by increasing the rate of dissolution, as does ARD. This technology has been applied successfully at field scale in the saturated zone at the Savannah River National Laboratory and other sites where methane gas is sparged into groundwater containing dissolved TCE. This technology has not been demonstrated for VOCs in the unsaturated zone.

Low-permeability and heterogeneous soils limit distribution of amendments. Implementability and effectiveness for VOCs in the UCRS are uncertain. This technology is retained for further consideration.

*Phytoremediation.* Phytoremediation exploits plant processes, including transpiration and rhizosphere enzymatic activity, to uptake water and dissolved-phase contaminants or to transform contaminants *in situ*. TCE may be transpired to the atmosphere or degraded in the root zone. The depth of VOC contamination at Southwest Plume sites is greater than the root zone of plants capable of transpiring or degrading TCE. Phytoremediation is not technically implementable at the PGDP Southwest Plume sites and therefore is screened from further consideration.

### **Physical/Chemical Technologies**

*Soil Vapor Extraction.* SVE applies vacuum to unsaturated soils to induce the controlled flow of air through contaminated intervals, thereby removing volatile contaminants from the soil. SVE can increase the rate of volatilization from DNAPL, aqueous, and sorbed VOC phases by maintaining a high concentration gradient between these phases and the air filled soil porosity.

The gas leaving the soil may be treated to recover or destroy the contaminants, depending on local and state air discharge regulations. Vertical extraction wells typically are used at depths of 1.5 m (5 ft) or greater and have been successfully applied as deep as 91 m (300 ft). Horizontal extraction vents installed

in trenches or horizontal borings can be used as warranted by contaminant zone geometry, drill rig access, or other site-specific factors. SVE is defined by EPA as a presumptive remedy for VOCs in soil (EPA 2007).

Impermeable covers often are placed over soil surface during SVE operations to prevent short circuiting of air flow and to increase the radius of influence of the wells. Groundwater depression pumps may be used to reduce groundwater upwelling induced by the vacuum or to increase the depth of the vadose zone. This application, called multiphase extraction, was evaluated and recommended by Hightower *et al.* (2001) as potentially effective and implementable for remediation of DNAPL TCE in saturated conditions in the UCRS at PGDP. Potential adjunct technologies to improve performance include fracturing, active or passive air injection, air sparging, and ozone injection, are discussed separately.

The typical target contaminant groups for *in situ* SVE are VOCs and some fuels. The technology typically is applicable only to volatile compounds with a Henry's law constant greater than 0.01 or a vapor pressure greater than 0.5 mm Hg (0.02 inches Hg). Other factors, such as the moisture content, organic content, and air permeability of the soil, affect effectiveness.

Factors that may limit the applicability and effectiveness of the process include the following:

- Soil that has a high percentage of fines and a high degree of saturation will require higher vacuums (increasing costs) and hindering the operation of the *in situ* SVE system.
- Large screened intervals are required in extraction wells for soil with highly variable permeabilities or stratification, which otherwise may result in uneven delivery of gas flow from the contaminated regions.
- Soil that has high organic content or is extremely dry has a high sorption capacity of VOCs, which results in reduced removal rates.
- Exhaust air from the *in situ* SVE system may require treatment to meet discharge requirements.
- Off-gas treatment residuals (e.g., spent activated carbon) may require treatment/disposal.
- SVE is not effective in the saturated zone; however, groundwater pumping (i.e., multiphase extraction) can expose more media to air flow (see section below for details).

Data requirements include the depth and areal extent of contamination, the concentration of the contaminants, depth to water table, and soil type and properties (e.g., structure, texture, permeability, and moisture content). Pilot studies may be performed to provide design information, including extraction well sizing, radius of influence, gas flow rates, optimal applied vacuum, and contaminant mass removal rates.

During full-scale operation, *in situ* SVE can be run intermittently (pulsed operation) after the mass removal rate has reached an asymptotic level. Pulsed operation can improve the cost-effectiveness of the system by facilitating extraction of higher concentrations of contaminants. After the contaminants are removed by *in situ* SVE, other remedial measures, such as biodegradation, can be investigated if remedial action objectives have not been met. *In situ* SVE projects typically are completed in 1 to 3 years (FRTR 2008).

This technology is potentially effective, technically implementable, and commercially available for treatment of VOCs in the UCRS. This technology is retained for further evaluation.

Multiphase Extraction. Multiphase extraction is an *in situ* technology that applies a high vacuum to pump various phases of contaminated groundwater, separate-phase (DNAPL), and vapor from the subsurface. Multiphase extraction process induces drawdown of the groundwater table, and consequently, increases vapor flow through the formation. Multiphase extraction also increases the mass removal of the volatile contaminants by maximizing dewatering and facilitating volatilization from previously saturated sediments via the increase of air movement. The depressed water table that results from the high recovery rates serves both to hydraulically control groundwater migration and to increase the efficiency of the vapor extraction. Multiphase extraction can increase the rate of volatilization from DNAPL, aqueous, and sorbed VOC phases by maintaining a high concentration gradient between these phases and the air filled soil porosity. The extracted liquids and vapor are treated and either collected for disposal, or re-injected to the subsurface.

The mass removal of aerobically biodegradable contaminants will be enhanced by the resulting induced air movement through the treatment zone, which increases oxygen concentrations available for aerobic microorganisms. Multiphase extraction is a unique remediation method as it relies on a combination of both air and water to act as carriers, whereas most remediation methods rely either on air or water as carriers.

Impermeable covers often are placed over soil surface during multiphase extraction operations to prevent short circuiting of air flow and to increase the radius of influence of the wells. Multiphase extraction was evaluated and recommended by Hightower *et al.* (2001) as potentially effective and implementable for remediation of DNAPL TCE in saturated conditions in the UCRS at PGDP, so it is believed to be equally effective in the RGA.

Factors that may limit the applicability and effectiveness of the process include the following:

- Low permeability soils result in difficulties related to dewatering the soils due to high air entry pressure.
- High heterogeneity in soil reduces the effectiveness due to channeling.
- This technique is difficult to apply to sites where the water table fluctuates unless water table depression pumps are employed.
- Large volumes of extracted groundwater will require treatment.

Data requirements include the depth and areal extent of contamination, the concentration of the contaminants, depth to water table, and soil type and properties (e.g., structure, texture, permeability, and moisture content). Pilot studies should be performed to provide design information, including extraction well sizing, radius of influence, gas flow rates, optimal applied vacuum, and contaminant mass removal rates.

Multiphase extraction projects typically are completed in 1 to 3 years.

This technology is potentially effective, technically implementable, and commercially available for treatment of VOCs in the RGA. This technology is retained for further evaluation.

Air Sparging. Air sparging injects air into contaminated groundwater. Injected air traverses horizontally and vertically in channels through the soil column allowing TCE and other VOCs to distribute into the air phase, creating an underground stripper that removes contaminants by volatilization and transport. This injected air helps to volatilize the contaminants that travel into the unsaturated zone, where they typically

are removed by an SVE system. This technology is designed to operate at high flow rates to maintain increased contact between groundwater and soil and strip more groundwater by sparging. Air sparging can act on aqueous, DNAPL and sorbed phase VOCs by promoting volatilization of VOCs into an air phase.

Oxygen added to contaminated groundwater and vadose zone soils also can enhance biodegradation of some contaminants below and above the water table. Ozone may be generated on-site and added to air injection or sparging systems to oxidize contaminants *in situ*. This application of sparging was recommended for evaluation by Hightower *et al.* (2001) for remediation of TCE sources in the UCRS unsaturated zone at the PGDP.

The target contaminant groups for air sparging are VOCs and fuels. Methane can be used as an amendment to the sparged air to enhance cometabolism of chlorinated organics.

Factors that may limit the applicability and effectiveness of the process include the following:

- Soil heterogeneity may cause some zones to be relatively unaffected or may result in uncontrolled movement of vapors, and
- Sparging tends to create preferential flowpaths that may bypass contaminated areas.

Characteristics that should be determined include vadose zone gas permeability, depth to water, groundwater flow rate, radial influence of the sparging well, aquifer permeability and heterogeneities, presence of low permeability layers, presence of DNAPLs, depth of contamination, and contaminant volatility and solubility. Additionally, it is often useful to collect air-saturation data in the saturated zone during an air sparging test, using a neutron probe.

This technology is demonstrated at numerous sites, though only a few sites are well documented. Air sparging has demonstrated sensitivity to minute permeability changes, which can result in localized stripping between the sparge and monitoring wells. Air sparging has a medium to long duration that may last up to a few years (FRTR 2008). Air sparging using ozone to remediate VOCs in UCRS soils at PGDP was estimated to require approximately one year (MK Corporation 1999).

This technology is potentially effective, technically implementable and commercially available for treatment of VOCs in the saturated zones of the UCRS; however, pilot-testing would be required to select and design the technology.

Soil Flushing. *In situ* soil flushing is the extraction of contaminants from soil with water or other suitable aqueous solutions. Soil flushing is accomplished by passing the extraction fluid through in-place soils using an injection or infiltration process. Extraction fluids must be recovered from the underlying aquifer and, when possible, they are recycled. Many soil flushing techniques are adapted from enhanced oil recovery methods used by the petroleum industry for many years. Soil flushing agents including cosolvents and surfactants are discussed here.

Cosolvent flushing involves injecting a solvent mixture (e.g., water plus a miscible organic solvent such as alcohol) into either vadose zone, saturated zone, or both to extract organic contaminants through solubilization into the cosolvent. Cosolvent flushing can be applied to soils to dissolve either the source of contamination or the contaminant plume emanating from it. The cosolvent mixture normally is injected upgradient of the contaminated area, and the solvent with dissolved contaminants is extracted downgradient and treated aboveground.

Surfactant flushing acts by reducing the interfacial tension between DNAPL and water or DNAPL and soil, thereby increasing the surface area for solubilization. Surfactant flushing can result in mobilization of DNAPL, and the process requires physical or hydraulic containment. Some soil flushing agents also can act on sorbed-phase VOCs.

Recovered contaminated groundwater and flushing fluids may need treatment to meet appropriate discharge standards prior to recycle or release to wastewater treatment works or receiving streams. Recovered fluids are reused in the flushing process to the extent practicable. The separation of surfactants from recovered flushing fluid, for reuse in the process, is a major factor in the cost of soil flushing. Treatment of the recovered fluids results in process sludges and residual solids, such as spent carbon and spent ion exchange resin, which must be appropriately treated before disposal. Air emissions of volatile contaminants from recovered flushing fluids should be collected and treated, as appropriate, to meet applicable regulatory standards. Residual flushing additives in the soil may be a concern and should be evaluated on a site-specific basis.

The duration of soil flushing process is generally short- to medium-term. Costs are high relative to most other *in situ* treatments. Flushing solutions may alter the physical/chemical properties of the soil system.

Factors that may limit the applicability and effectiveness of the process include the following:

- Low permeability or heterogeneous soils are difficult to treat. Effectiveness and technical implementability of soil flushing at the PGDP Southwest Plume sites are uncertain due to the heterogeneity and variable extent of saturation in the UCRS soils, resulting in difficult conditions for injecting and circulating liquid amendments.
- Surfactants can adhere to soil and reduce effective soil porosity.
- Reactions of flushing fluids with soil can reduce contaminant mobility.
- Control of mobilized fluids, in particular NAPLs, is critical to success. The technology should be used only where flushed contaminants and soil flushing fluid can be contained and recaptured.
- Aboveground separation and treatment costs for recovered fluids can drive the economics of the process.

Treatability tests may be considered to determine the feasibility of the specific soil-flushing process being considered. Physical and chemical soil characterization parameters that should be established include soil permeability, soil structure, soil texture, soil porosity, moisture content, total organic carbon, cation exchange capacity, pH, and buffering capacity.

Contaminant characteristics that should be established include concentration, solubility, partition coefficient, solubility products, reduction potential, and complex stability constants. Soil and contaminant characteristics will determine the flushing fluids required, flushing fluid compatibility, and changes in flushing fluids with changes in contaminants.

Soil flushing is a developing technology that has had limited use in the United States. Typically, laboratory and possibly field treatability studies may be performed under site-specific conditions before soil flushing is selected as the sole remedy of choice. To date, the technology has been selected as part of the source control remedy at 12 Superfund sites. There has been very little commercial success with this technology (FRTR 2008). This technology is retained for further evaluation.

Electrokinetics. The principle of electrokinetic remediation relies upon application of a low-intensity direct current through the soil between ceramic electrodes that are divided into a cathode array and an anode array. This mobilizes charged species, causing ions and water to move toward the electrodes. Metal ions, ammonium ions, and positively charged organic compounds move toward the cathode. Anions such as chloride, cyanide, fluoride, nitrate, and negatively charged organic compounds move toward the anode. The current creates an acid front at the anode and a base front at the cathode.

The two primary mechanisms, electromigration and electroosmosis, transport contaminants through the soil toward one or the other electrodes. In electromigration, charged particles are transported through the stationary soil moisture. In contrast, electroosmosis is the movement of the soil moisture containing ions relative to a stationary charged surface. The direction and rate of movement of an ionic species will depend on its charge, both in magnitude and polarity, as well as the magnitude of the electroosmosis-induced flow velocity. Non-ionic species, both inorganic and organic, also will be transported along with the electroosmosis induced water flow. Electrokinetics can act on aqueous, DNAPL, and sorbed phase VOCs. Electroosmosis has been used for years in the construction industry to dewater low-permeability soils.

Two approaches are taken during electrokinetic remediation: “Enhanced Removal” and “Treatment without Removal.” “Enhanced Removal” is achieved by electrokinetic transport of contaminants toward the polarized electrodes to concentrate the contaminants for subsequent removal and *ex situ* treatment. Removal of contaminants at the electrode may be accomplished by several means including electroplating at the electrode, precipitation or co-precipitation at the electrode, pumping of water near the electrode, or complexing with ion exchange resins. Enhanced removal is widely used in remediation of metals-contaminated soils.

“Treatment without Removal” is achieved by electro-osmotic transport of contaminants through treatment zones placed between electrodes. The polarity of the electrodes is reversed periodically, which reverses the direction of the contaminants back and forth through treatment zones. The frequency with which electrode polarity is reversed is determined by the rate of transport of contaminants through the soil. This approach can be used on *in situ* remediation of soils contaminated with organic species.

Targeted contaminants for electrokinetics are heavy metals, anions, and polar organics; in soil, mud, sludge, and sediments. Concentrations that can be treated range from a few ppm to tens of thousands ppm. Electrokinetics is applicable most in low permeability soils. Such soils are typically saturated and partially saturated clays and silt-clay mixtures that are not readily drained.

Factors that may limit the applicability and effectiveness of this process include the following:

- Effectiveness is sharply reduced for wastes with a moisture content of less than 10%. Maximum effectiveness occurs if the moisture content is between 14% and 18%.
- The presence of buried metallic or insulating material can induce variability in the electrical conductivity of the soil, therefore, the natural geologic spatial variability should be delineated. Additionally, deposits that exhibit very high electrical conductivity, such as ore deposits, cause the technique to be inefficient.
- Inert electrodes, such as carbon, graphite, or platinum, must be used so that no residue will be introduced into the treated soil mass. Metallic electrodes may dissolve as a result of electrolysis and introduce corrosive products into the soil mass.

- Electrokinetics is most effective in clays because of the negative surface charge of clay particles; however, the surface charge of the clay is altered by both changes in the pH of the pore fluid and the adsorption of contaminants. Extreme pH at the electrodes and reduction-oxidation changes induced by the process electrode reactions may inhibit electrokinetics effectiveness.
- Oxidation/reduction reactions can form undesirable products (e.g., chlorine gas).

In addition to identifying soil contaminants and their concentrations, information necessary for engineering electrokinetic systems to specific applications includes soil moisture content and classification, soil pH, bulk density, pH, and cation-anion balance. Process-limiting characteristics such as pH or moisture content sometimes may be adjusted. In other cases, a treatment technology may be eliminated based upon the soil classification (e.g., particle-size distribution) or other soil characteristics.

The electrokinetic technology has been operated for test and demonstration purposes at the pilot scale and at full scale at a number of sites including the PGDP SWMU 91. The PGDP field test implemented the Lasagna™ process, a patented and trademarked “treatment without removal” electrokinetic soil treatment. The system uses a series of planar electrodes emplaced at the outer edge of a source zone, from 6.1 to 30.5 m (20 to 100 ft) apart. Treatment zones for TCE consist of iron filings and clay emplaced between and parallel to the electrode zones. When the power is on, the soil is heated and pore water travels from the anode toward the cathode. TCE is broken down into nonhazardous compounds as it comes in contact with the iron particles in the treatment zones.

In 1994, PGDP SWMU 91, the Cylinder Drop Test Area, was selected for the demonstration of the Lasagna™ technology. TCE was present in UCRS soils and groundwater at concentrations indicative of residual saturation to a depth of approximately 13.7 m (45 ft) bgs.

Phase I of the SWMU 91 Lasagna™ demonstration began in January 1995 and lasted for 120 days. The purpose of Phase I was to collect sufficient experience and information for site-specific design, installation, and operation of the Lasagna™ technology. Lasagna™ Phase IIa began in August 1996 and lasted 12 months. The purpose of Phase IIa was to perfect methods for installing treatment and electrode zones. During the technology demonstration, the average concentration of TCE in the target soil was reduced by approximately 95%.

Following the successful field-scale test DOE issued the *Record of Decision for Remedial Action at Solid Waste Management Unit 91 of Waste Area Group 27 at the Paducah Gaseous Diffusion Plant, Paducah, Kentucky* (DOE 1998b). The ROD designated Lasagna™ as the selected remedial alternative for reducing the concentration of TCE in SWMU 91. Following installation, the Lasagna™ system was operated for two years to reduce the concentration of TCE in SWMU 91 soils to the RGs established in the SWMU 91 ROD (DOE 2002b).

This technology has been demonstrated at the PGDP to be effective, technically implementable, and commercially available for remediation of VOCs in soil. This technology is retained for further evaluation.

**Soil Mixing.** Several types of deep soil mixing systems are commercially available, including single- and dual-auger systems. Dual-auger soil mixing involves the controlled injection and blending of reagents into soil through dual overlapping auger mixing assemblies, consisting of alternate sections of auger flights and mixing blades that rotate in opposite directions to pulverize the soil and blend in the appropriate volumes of treatment reagents. Each auger mixing assembly is connected to a separate, hollow shaft (Kelly-bar) that conveys the treatment reagents to the mixing area, where the reagents are injected through nozzles located adjacent to the auger cutting edge. The mix proportions, volume, and injection

pressures of the reagents are continuously controlled and monitored by an electronic instrumentation system. This technology has been widely used for grout injection and ground improvement in the civil and geotechnical construction industry for many years. *In situ* soil mixing is most effective at depths to 40 ft bgs; however, depths to 100 ft may be treated using smaller diameter augers (DOE 1996b).

During the mixing operation, the dual auger flights break the soil loose allowing the mixing blades to blend the reagents and the soil into a homogeneous mixture. As the augers advance to a greater depth, the soil and reagent(s) are re-mixed by an additional set of augers and mixing blades located above the preceding set on each shaft. When the desired depth is reached, the augers are reversed and withdrawn and the mixing process is repeated on the way to the surface, leaving a homogeneously treated block of soil. Each treated block of soil is composed of two overlapping columns. The pattern of columns is extended laterally in rows of treated blocks, in a repetitive manner to encompass the total area of the required remediation. The depth of the columns encompasses the vertical extent of the remediation. A hood and filter system can be added to the dual auger soil mixing system, therefore, eliminating the possibility of contaminants escaping into the atmosphere (ISF 2008).

Deep soil mixing potentially can reduce mass transfer limitations associated with UCRS soils, including low-permeability soils and partial saturation, by physically blending contaminated soils with amendments or heated air or water. Soil mixing can act on aqueous, DNAPL, and sorbed phase VOCs. Deep soil mixing has been demonstrated to remove up to 95% of VOCs in soil, through ZVI injection, hot air/steam stripping, and injection of bioremediation reagents (ISF 2008). This technology may require a pilot demonstration at the PGDP prior to full-scale implementation. This technology is potentially effective, technically implementable, and commercially available for remediation of VOCs in soil. This technology is retained for further evaluation.

Injection Technologies. Injection delivery mechanisms involve the placement of chemical or biological amendments into the subsurface. Amendments can be injected into the vadose zone and/or groundwater to treat contaminated media *in situ*. The injection method chosen is usually site-specific and is dependent on site characteristics such as hydrogeology, geology, geochemistry, contaminant type and distribution, and the depth of target treatment. In general, a well characterized source zone is necessary for an injection system to be effective.

*Groundwater Recirculation Wells.* The most direct route of injection utilizes existing MWs, piezometers, or injection wells. Recirculation is a technique that involves injecting amendments in upgradient wells, while downgradient wells extract groundwater. The extracted groundwater typically is mixed with additional amendment and reinjected in the injection well. The wells keep the water in the aquifer in contact with the amendment and also may prevent the larger agglomerated particles of the amendment from settling out, allowing continuous contact with the contaminant. This technique is typically applied to saturated and hydraulically conductive formations and used with relatively stable oxidants such as potassium permanganate (KMnO<sub>4</sub>). This technology is not feasible for implementation in the UCRS due to the relatively nontransmissive, unsaturated nature of the formation.

*DPT.* The direct push method involves driving direct push rods progressively deeper into the ground either by static push or dynamic push force. Hydraulic rams typically are used to provide a static pushing mechanism, and hammer devices are used to provide a dynamic force. Reagents can be injected through direct push injection screens installed using DPT. Using DPT, screens can be deployed across several vertical target zones, ensuring delivery of the reagent across the entire vertical extent of the target treatment zone. DPT is not applicable when cobbles or consolidated materials are present. The depth of penetration is controlled primarily by the reactive weight of the equipment or the type of hammer used (e.g., vibratory, manual, percussion). Consequently, direct push technologies are most applicable in unconsolidated sediments, typically to depths less than 100 ft. This method is relatively inexpensive and



allows materials to be injected without having to install permanent MWs (Butler 2000). This technology is retained for further evaluation.

*Pressure-pulse Technology.* Pressure-pulse technology utilizes large-amplitude pulses of pressure to insert an amendment slurry into porous media at the water table; the pressure then excites the media and increases fluid level and flow (OCETA 2003). This capability of driving liquids through the porous media facilitates recovery of contaminants in the form of light nonaqueous-phase liquids (LNAPL) and DNAPL. As with soil fracturing, pressure-pulse technology can extend the range of treatment when combined with other primary injection and extraction technologies such as bioremediation, chemical oxidation/reduction, or SVE. Pressure-pulse technology for these uses is discussed as a secondary technology in the discussion of the primary technology. This technology is retained for further analysis.

*Jet Grouting.* Grout mixtures injected at high pressures and velocities into the pore spaces of the soil or rock have been used in civil construction for many years to stabilize subgrades and reduce infiltration of water. More recently, jet grouting has been used to inject high pressure streams of grout (single fluid jet grouting), grout-air mixtures (double fluid jet grouting), or grout-air-liquid mixtures (triple fluid jet grouting) to treat and/or immobilize contaminants present in subsurface soils. Double or triple fluid jet grouting can be used to emplace a reagent into the subsurface. The grout-fluid mixture is typically injected through a small diameter drill rod at high pressures (5000 psi to 6000 psi). The drill rods are slowly rotated and raised to create columns of soil-reagent-cement mixture. The shape of the grouted zone can be changed by directing the grout in ways to create panels, floors, or other shapes. This technology is commonly used to create barriers in areas with poor accessibility due to the capability to create geometrically different grouted areas with a small diameter auger. Jet grouting can be used in soil types ranging from gravel to clay, but the soil type can alter the diameter of the treated column. Soil properties also are related to the efficiency. For instance, jet grouting in clay is less efficient than in sand (EPA 1999a).

V-shaped jet-grouted composite barriers were demonstrated at Brookhaven and the Hanford Site (Dwyer 1994) and at Fernald in 1992 (Pettit *et al.* 1996) in attempts to completely isolate contaminated soils in field trials. These case studies are examples of single fluid jet grouting. At Hanford and Brookhaven, V-shaped grouted barriers were created by injecting grout through the drill strings of rotary/percussion directional drilling rigs. Next, a waterproofing polymer (AC-400) was placed as a liner between the waste form and the cement v-trough, forming a composite barrier. Technologies to determine the continuity and impermeability of the completed barrier are unavailable; therefore, the effectiveness of the completed barriers is uncertain.

EarthSaw™ is an innovative emerging jet grouting technology for construction of barriers under and around buried waste without excavating or disturbing the waste. Again, the construction of barriers is an example of the single fluid jet grouting method. A deep vertical slurry trench is dug around the perimeter of a site and the trench is filled with high-specific-gravity grout sealant. A horizontal bottom pathway is cut at the base of the trench with a cable saw mechanism. The large density difference between the grout and the soil allows the severed block of earth to float. The grout then cures into a relatively impermeable barrier. After the grout has cured and hardened, a final surface covering may be applied, resulting in a completely isolated monolith. This technology has only been demonstrated at the proof-of-principle stage (DOE 2002a).

Overall, single fluid jet grouting is the least effective jet grouting method. Single fluid jet grouting provides means for containment of contamination, but not treatment or removal of PTW. Double and triple fluid jet grouting is more effective than single fluid and can treat PTW by injecting a reagent mixture into the subsurface. Effectiveness and implementability of this technology are more uncertain than alternative *in situ* treatment technologies such as deep soil mixing. Because of the high relative cost

and large amounts of waste generated during the classic methods of jet grouting (single, double, or triple fluid jet grouting), this technology is feasible only in highly industrialized areas with subsurface utilities where deep soil mixing is not a viable option. In addition, one principal mode of effectiveness is via a reduction of mobility rather than treatment. Treatment is preferred by the NCP. For these reasons, jet grouting is screened from further consideration.

*Liquid Atomization Injection (LAI)*. Liquid atomization injection is a technology that is proprietary to ARS Technologies, Inc., a company that specializes in pneumatic fracturing and injection field services. LAI is an injection delivery mechanism that injects a reagent into the subsurface in an aerosolized state. LAI is typically implemented using a direct-push rig or sonic-drill rig to create a temporary 4-inch borehole. Following drilling, LAI utilizes a small diameter wand or lance to inject reagents into the subsurface at high pressures. A reagent is mixed on the surface and introduced into a high-flow, high-velocity gas stream at the well head. When the gas stream is injected into low permeability formations, the injection technique essentially pneumatically fractures the formation while simultaneously injecting the aerosolized reagent; when injected into relatively higher permeability formations (i.e., sands and gravels), LAI is essentially a soil mixing technique. The fracturing process creates a network of artificial fractures that facilitate the introduction of amendments into the subsurface. Unconsolidated materials such as silts and clays typically exhibit fracture propagation distances of 20 ft to 40 ft. Grout is not injected as part of the LAI/pneumatic fracturing process, due to past successes remediating source areas “outward in” and “bottom up,” which inherently limits the potential for contaminant migration outside the source area.

LAI may be implemented at a lower relative cost than jet grouting with significantly less waste generated. LAI provides a means for treating PTW via injection of a reagent into the subsurface. The effectiveness and implementability are more uncertain than alternative *in situ* treatment technologies such as deep soil mixing. Pilot tests using the LAI technology to inject potassium permanganate (KMnO<sub>4</sub>) into the subsurface to treat TCE contamination *in situ* were conducted in Oklahoma and Georgia (CH2M HILL NDA). The pilot tests concluded that pneumatic fracturing and LAI are effective means of distributing oxidants into low permeability formations. Due to the uncertain effectiveness and implementability, pneumatic fracturing and LAI are screened from further analysis at the Oil Landfarm where alternative means of *in situ* remediation (e.g., deep soil mixing) are possible; however, this technology is retained for further evaluation at C-720 Northeast and Southeast Sites where subsurface utilities may limit the technologies potentially implemented.

## **Thermal Technologies**

Electrical Resistance Heating. Electrical resistance heating (ERH) uses electrical resistance heaters or electromagnetic/fiber optic/radio frequency heating to increase the volatilization rate of volatiles and semivolatiles and facilitate vapor extraction. The vapor extraction component of ERH requires heat-resistant extraction wells, but is otherwise similar to SVE.

Contaminants in low-permeability soils such as clays and fine-grained sediments can be vaporized and recovered by vacuum extraction using this method. Electrodes are placed directly into the soil matrix and energized so that electrical current passes through the soil, creating a resistance which then heats the soil. The heat may dry out the soil causing it to fracture. These fractures make the soil more permeable allowing the use of SVE to remove the contaminants.

The heat created by ERH also forces trapped liquids, including DNAPLs, to vaporize and move to the steam zone for removal by SVE. ERH applies low-frequency electrical energy in circular arrays of three (three-phase) or six (six-phase) electrodes to heat soils. The temperature of the soil and contaminant is increased, thereby increasing the contaminant’s vapor pressure and its removal rate. ERH also creates an

*in situ* source of steam to strip contaminants from soil. Heating via ERH also can improve air flow in high moisture soils by evaporating water, thereby improving SVE performance. ERH can act on aqueous, DNAPL, and sorbed phase VOCs.

Six-phase heating (SPH) was evaluated and recommended by Hightower *et al.* (2001) for TCE DNAPL contamination in the saturated and unsaturated zones of the UCRS. A pilot study using SPH subsequently was conducted at PGDP between February and September of 2003. The heating array was 9.14 m (30 ft) in diameter and reached a depth of 30.2 m (99 ft) bgs. Baseline sampling results showed an average reduction in soil contamination of 98% and groundwater contamination of 99% (DOE 2003).

The following factors may limit the applicability and effectiveness of the process:

- Debris or other large objects buried in the media can cause operating difficulties;
- Low-permeability soils or soils with high moisture content have a reduced permeability to air, requiring more energy input to increase vacuum and temperature;
- Soils with a high organic content have a high VOC sorption capacity, which results in reduced removal rates;
- Air emissions may need to be regulated to eliminate possible harm to the public and the environment; and
- Residual liquids and spent activated carbon may require further treatment.

Data requirements include the depth and areal extent of contamination, the concentration of the contaminants, depth to the water table, and soil type and properties including structure, texture, permeability, organic carbon content, electrical properties, moisture content, and water velocity in saturated conditions.

Durations of thermally enhanced remediation projects are highly dependent upon the site-specific soil and chemical properties. The typical site consisting of 20,000 tons of contaminated media would require approximately nine months to remediate (FRTR 2008). This technology has been demonstrated at the PGDP for removal of DNAPL TCE and its degradation products with success in the UCRS and variable success in the RGA. This technology is retained for further evaluation.

Steam Stripping. Hot air or steam is injected below the contaminated zone to heat contaminated soil and thereby enhance the release of VOCs and some SVOCs from the soil matrix. Desorbed or volatilized VOCs are removed through SVE (FRTR 2008). Steam injection has been used to enhance oil recovery for many years and was investigated for environmental remediation beginning in the 1980s. Approximately 10 applications of this technology for recovery of fuels, solvents and creosote are reported in EPA (2005), with varied results.

*In situ* steam stripping is commonly applied using soil mixing equipment to improve contact of steam with contaminated media. Steam stripping can act on aqueous, DNAPL, and sorbed phase VOCs. This technology is retained for further consideration.

### **Chemical Technologies**

Chemical technologies are processes like ISCO whereby chemical compounds are injected to degrade organic contaminants in the subsurface. Table 2.4 provides a comparative evaluation of several

commercially available amendments. The criteria provided in the comparative evaluation can be used to screen certain amendments based on site conditions and the selected delivery mechanism, as applicable. Commercially available chemical technologies described in this section include the following:

- Permanganate
- Fenton's reagent
- ZVI (Note: although ZVI is not an oxidant, it is included in this discussion because delivery and effectiveness are similar)
- Ozonation
- Persulfate
- Redox manipulation

ISCO has been used at many sites, and oxidants are available from a variety of vendors. Water-based oxidants can react directly with the dissolved-phase of NAPL contaminants, since the organics and the water have limited solubility in one another. This property limits their activity to the oxidant solution/DNAPL interface; however, significant mass reduction has been reported for application of ISCO at sites with dissolved-phase VOCs and DNAPL residual ganglia (EPA CLU-IN 2008).

Data needs include heterogeneity of the site subsurface, soil oxidation demand, stability of the oxidant, and type and concentration of the contaminant. Effectiveness and technical implementability of ISCO at the PGDP Southwest Plume sites is uncertain due to the relatively low permeability, heterogeneity and variable extent of saturation in the UCRS soils, resulting in difficult conditions for injecting and circulating liquid amendments.

Permanganate. Permanganate typically is provided as a water solution or a solid potassium permanganate (KMnO<sub>4</sub>), but is also available in sodium, calcium, or magnesium salts. The following equation represents the chemical oxidation of TCE using potassium permanganate:



The use of permanganate to degrade TCE causes the generation of salts and hydrogen or hydroxyl ions (acids or bases) with no significant pH shifts. The direct application of permanganate has commonly been used for contaminant levels up to 100 ppm to avoid off-gassing. It has only recently been applied to contaminant levels exceeding 1,000 ppm. Permanganate can be delivered to the contaminated zone by injection probes, soil fracturing, soil mixing, and groundwater recirculation (EPA 2004b). Permanganate has an effective pH range of 3.5 to 12 (KRCEE 2005). This technology may potentially be effective and technically implementable in the UCRS, but has the same limitations as other aqueous-phase oxidants (i.e., it may have sufficient effectiveness in heterogeneous matrices or not act sufficiently on DNAPL). Secondary effects may include discoloration of water for some time after treatment.

Fenton's Reagent. Hydrogen peroxide (H<sub>2</sub>O<sub>2</sub>) was one of the first chemical oxidants to be used in industry and was commercialized in the early 1800s. Hydrogen peroxide works as a remedial chemical oxidant in two ways: (1) direct chemical oxidation as hydrogen peroxide and (2) in the presence of native or supplemental ferrous iron (Fe<sup>+2</sup>), as Fenton's Reagent, which yields hydroxyl free radicals (OH<sup>•</sup>). These strong, nonspecific oxidants can rapidly degrade a variety of organic compounds. Fenton's Reagent oxidation is most effective under very acidic pH and becomes ineffective under moderate to strongly alkaline conditions.

**Table 2.4. Comparative Evaluation of Commercially Available Chemical Amendments**

<b>Evaluation Criteria</b>	<b>Potassium permanganate<sup>1</sup></b>	<b>Sodium permanganate<sup>1</sup></b>	<b>Sodium persulfate/ activator<sup>a1</sup></b>	<b>Hydrogen peroxide/ ferrous iron<sup>1</sup></b>	<b>Ozone<sup>1</sup></b>	<b>Ozone/ hydrogen peroxide<sup>1</sup></b>	<b>Zero valent iron (ZVI)<sup>23</sup></b>
<b>Degradation of TCE</b>	Yes	Yes	Yes	Yes	Yes		Yes
<b>Persistence</b>	Very stable	Very stable	Very stable	Easily degraded in soil/groundwater unless inhibitors used.	Easily degraded in soil/groundwater.		Dependent on particle size and presence of oxidative molecules.
<b>Vadose Zone Considerations</b>	Hydration required via 1) injection of large quantities of oxidant <sup>b</sup> , 2) artificial hydration, or 3) surfactants.				Hydration not required (but water may increase hydroxyl radical production).		Water is required, but amount should be minimized. <sup>c</sup>
<b>Low Soil Permeability Considerations</b>	Low soil permeability is a barrier. <sup>d</sup>				Low soil permeability is a barrier. <sup>d</sup> However, higher permeability to gas (i.e., ozone) than to liquid.		Low soil permeability is a barrier. <sup>d</sup>
<b>Metal Mobilization Considerations</b>	Metals can be mobilized within the treatment zone due to a change in oxidation states and/or pH.						An increase in pH precipitates metals.
<b>Oxidant Loading Requirements</b>	Optimal loading, considering both target and nontarget compounds, should be determined before injection.						Based on soil amount. <sup>e</sup>

<sup>a</sup>Heat, ferrous iron, or elevated pH.

<sup>b</sup>Generally ineffective and has potential to increase contaminant release and migration.

<sup>c</sup>Oxygen, nitrates, and sulfates present in the water can oxidize the ZVI. If large volume of water is necessary, it should be deoxygenated.

<sup>d</sup>The oxidant must be evenly dispersed throughout the contaminated soil matrix with minimal forced migration of the contamination outside the treatment area.

<sup>e</sup>A reducing environment that is strong enough to minimize the formation of chlorinated intermediates (e.g., dichloroethene or vinyl chloride) may be optimal. Based on Navy field demonstrations, enough ZVI mass should be injected to lower the oxidation-reduction potential below -400 mV; an iron-to-soil ratio of 0.004 is necessary to create the required potential. Iron requirements are not based on contaminant mass.

References

1. ITRC (Interstate Technology & Regulatory Council) 2005. Technical and Regulatory Guidance for *In situ* Chemical Oxidation of Contaminated Soil and Groundwater, 2nd ed. ISCO-2, Washington, DC: ITRC, *In situ* Chemical Oxidation Team, Available at <http://www.itrcweb.org>.
2. NAVFAC ESC (Naval Facilities Engineering Command/Engineering Service Center) 2005. Cost and Performance Report, Nanoscale Zero-Valent Iron Technologies for Source Remediation, Contract Report CR-05-007-ENV.
3. NAVFAC ESC 2005. Nanoscale Zero Valent Iron Training Tool, Environmental Restoration Technology Transfer (ERT2), Multimedia Training Tools Web site, Available at <http://www.ert2.org/ert2portal/DesktopDefault.aspx>.

The most common field applications of chemical oxidation have been based on Fenton's Reagent. When peroxide is injected into the subsurface at concentrations of 10% to 35% in the presence of ferrous iron, the hydroxyl free radical oxidizes the VOCs to carbon dioxide (CO<sub>2</sub>) and water. The residual hydrogen peroxide decomposes into oxygen and water, and the remaining iron precipitates (Jacobs and Testa 2003).

The oxidation reaction for TCE forms several unstable daughter products such as epoxides that break down to aldehydes and ketones, which then finally decompose to carbon dioxide, chloride ions, and water as shown in the following reaction (Jacobs and Testa 2003).

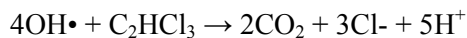

The pH of the surrounding medium increases as the reaction process continues; therefore, it is necessary to lower the pH with acids. Organic acids should be avoided because they have a tendency to increase side reactions. The optimal pH range is from 3.5 to 5.0. The exothermic nature of the oxidation process causes a rise in subsurface temperature which may decompose the peroxide. Field research has determined the optimal reaction temperature to be in the range of 35 to 41 °C (Jacobs and Testa 2003). This technology potentially may be effective and technically implementable in the UCRS, but has the same limitations as other aqueous-phase oxidants (i.e., it may not be effective in heterogeneous matrices or act sufficiently on DNAPL).

Zero-Valent Iron. ZVI often is used in conjunction with a permeable reactive barrier to dechlorinate chlorinated hydrocarbons in the subsurface; however, the technology also may be applied as direct injection of particulate iron, mixing of iron with clay slurries or incorporating nanoscale ZVI into an oil emulsion prior to injection. A form of ZVI may be injected into the subsurface downgradient of the contaminant source to create a zone of treatment. Technical implementability in the UCRS would be constrained by low-permeability soil layers and heterogeneity. This technology is potentially technically implementable and commercially available and is retained for further evaluation.

Ozonation. Ozone (O<sub>3</sub>) is a strong oxidizer having an oxidation potential about 1.2 times that of hydrogen peroxide. Because of its instability, ozone typically is generated on-site and delivered to the contaminated zone through sparge wells. Air containing up to 5% ozone is injected through strategically placed sparge wells. Ozone dissolves in the groundwater and oxidizes the contaminant while decomposing to oxygen (O<sub>2</sub>).

Ozone injection was evaluated and recommended by Hightower *et al.* (2001) for remediation of DNAPL TCE in the unsaturated zone of the UCRS at the PGDP. Pneumatic fracturing can be used to enhance ozone treatment effectiveness in low permeability soils (EPA 2004b). This technology potentially may be effective and technically implementable in the UCRS, but has the same limitations as other aqueous-phase oxidants (i.e., it may not be effective in heterogeneous matrices or act sufficiently on DNAPL).

Sodium Persulfate. Persulfate is a strong oxidant with a higher oxidation potential than hydrogen peroxide and a potentially lower soil oxygen demand than permanganate or peroxide. Persulfate reaction is slow unless placed in the presence of a catalyst, such as ferrous iron, or heated to produce sulfate free radicals that are highly reactive and capable of degrading many organic compounds. The ferrous iron catalyst, when used, will degrade with time and precipitate. Persulfate becomes especially reactive at temperatures above 40 °C (104 °F), and can degrade most organics (EPA CLU-IN 2008).

This technology potentially may be effective and technically implementable in the UCRS, but has the same limitations as other aqueous-phase oxidants (i.e., it may not be effective in heterogeneous matrices or act sufficiently on DNAPL).

Redox Manipulation. *In situ* redox manipulation (ISRM) manipulates natural processes to change the mobility or form of contaminants in the subsurface. ISRM creates a permeable treatment zone by injection of chemical reagents, such as sodium dithionite and/or microbial nutrients into the subsurface downgradient of the contaminant source. The chemical reagent then reacts with iron naturally present in the aquifer sediments in the form of various minerals present as clays, oxides, or other forms. Redox sensitive metals that migrate through the reduced zone in the aquifer may become immobilized and organic species may be destroyed (DOE 2000c). This technology is potentially technically implementable and commercially available and is retained for further evaluation.

***Ex Situ Treatment.*** *Ex situ* treatment technologies may be applicable to treatment of secondary wastes including recovered DNAPL TCE, excavated soils, extracted groundwater, or vapor. *Ex situ* treatment technologies potentially applicable to secondary wastes that may be generated during removal, treatment, or disposal at the Oil Landfarm and the C-720 Northeast and Southeast Sites are discussed here.

### **Physical/Chemical Technologies**

Air Stripping. Air stripping removes volatile organics from extracted groundwater by greatly increasing the surface area of the contaminated water exposed to air. Air stripping is a presumptive technology for treatment of VOCs in extracted groundwater (EPA 1996). Air stripping may potentially be applicable to secondary waste treatment from groundwater extraction, light nonaqueous-phase liquid recovery processes, or *in situ* treatment processes. Types of aeration methods include packed towers, diffused aeration, tray aeration, and spray aeration.

Air stripping involves the mass transfer of volatile contaminants from water to air. For groundwater remediation, this process typically is conducted in a tray aerator, packed tower, or aeration tank. Tray aerators stack a number of perforated trays vertically in an enclosure. Air is blown upward through the perforations as water cascades downward through the trays. Tray aerators occupy relatively little space, are easy to clean, and are highly efficient. Currently the PGDP Northwest Plume Pump-and-Treat system includes low-profile tray air stripping for TCE removal.

Packed tower air strippers typically include a spray nozzle at the top of the tower to distribute contaminated water over the packing in the column, a fan to force air countercurrent to the water flow, and a sump at the bottom of the tower to collect decontaminated water. Auxiliary equipment that can be added to the basic air stripper includes an air heater to improve removal efficiencies; automated control systems with sump level switches and safety features, such as differential pressure monitors, high sump level switches, and explosion-proof components; and air emission control and treatment systems, such as activated carbon units, catalytic oxidizers, or thermal oxidizers. Packed tower air strippers are installed either as permanent installations on concrete pads or on a skid or a trailer.

Aeration tanks strip volatile compounds by bubbling air into a tank through which contaminated water flows. A forced air blower and a distribution manifold are designed to ensure air-water contact without the need for any packing materials. The baffles and multiple units ensure adequate residence time for stripping to occur. Aeration tanks typically are sold as continuously operated skid-mounted units. The advantages offered by aeration tanks are considerably lower profiles (less than 2 m or 6 ft high) than packed towers (5 to 12 m or 15 to 40 ft high) where height may be a problem, and the ability to modify performance or adapt to changing feed composition by adding or removing trays or chambers. The discharge air from aeration tanks can be treated using the same technology as for packed tower air discharge treatment.

Air strippers can be operated continuously or in a batch mode where the air stripper is intermittently fed from a collection tank. The batch mode ensures consistent air stripper performance and greater energy efficiency than continuously operated units because mixing in the storage tanks eliminates any inconsistencies in feed water composition.

Due to substantive permitting requirements, liquid and air effluents may require monitoring prior to release, but monitoring of the air effluent also may be necessary based on Commonwealth of Kentucky and EPA requirements. Data needs include influent flow rate, VOC concentrations, VOC chemical and physical properties, iron content, dissolved solids, total hardness, alkalinity, and pH. Air and water discharge limits also are required.

Air stripping is effective, technically implementable and commercially available for removal of VOCs from extracted groundwater. This technology is retained for further evaluation.

Ion Exchange. Ion exchange removes ions from the aqueous phase by exchanging cations or anions between the contaminants and the exchange medium. Ion exchange materials may consist of resins made from synthetic organic materials that contain ionic functional groups to which exchangeable ions are attached. Resins also may be inorganic and natural polymeric materials. After the resin capacity has been exhausted, resins can be regenerated for reuse. Wastewater is generated during the regeneration step, potentially requiring additional treatment and disposal.

These factors may affect the applicability and effectiveness of ion exchange (FRTR 2008):

- Oil and grease in the groundwater may clog the exchange resin;
- Suspended solids content greater than 10 ppm may cause resin blinding;
- The pH of the influent water may affect the ion exchange resin selection; and
- Oxidants in groundwater may damage the ion exchange resin.

VOCs are not removed by this method; however, removal of radionuclides including Tc-99 from extracted groundwater using ion exchange is effective, technically implementable, and commercially available. This technology is retained for further evaluation.

Granular-Activated Carbon (Vapor Phase). Vapor-phase carbon adsorption removes pollutants including VOCs removed from extracted air by physical adsorption onto activated carbon grains. Carbon is “activated” for this purpose by processing the carbon to create porous particles with a large internal surface area (300 to 2,500 m<sup>2</sup> or 3,200 to 27,000 ft<sup>2</sup> per gram of carbon) that attracts and adsorbs organic molecules as well as certain metal and inorganic molecules.

Commercial grades of activated carbon are available for specific use in vapor-phase applications. The granular form of activated carbon typically is used in packed beds through which the contaminated air flows until the concentration of contaminants in the effluent from the carbon bed exceeds an acceptable level. Granular-activated carbon (GAC) systems typically consist of one or more vessels filled with carbon connected in series and/or parallel operating under atmospheric, negative, or positive pressure. The carbon then can be regenerated in place, regenerated at an off-site regeneration facility, or disposed of, depending upon economic considerations.

Carbon can be used in conjunction with steam reforming. Steam reforming is a technology designed to destroy halogenated solvents (such as carbon tetrachloride and chloroform) adsorbed on activated carbon by reaction with superheated steam.



GAC is effective, technically implementable and commercially available for removal of VOCs from extracted air. This technology is retained for further evaluation.

Vapor Condensation. TCE and other VOCs in contaminated vapor streams can be cooled to condense the contaminants (EPA 2006). The contaminant-laden vapor stream is cooled below the dew point of the contaminants, e.g., below about 37.2 °C (99 °F) for TCE, and the condensate can be collected for recycling or disposal. Methods used to cool the vapor stream may include the use of liquid nitrogen, mechanical chilling, or a combination of the two.

Condensation systems are most often used when the vapor stream contains concentrations of contaminants greater than 5,000 ppm or when it is economically desirable to recover the organic contaminant contained in the vapor stream for reuse or recycling. Other configurations of vapor condensation include adsorbing or otherwise concentrating compounds from low-concentration vapors using another technology (e.g., GAC) and then performing condensation for recovery for disposal or recycling.

Vapor condensation of TCE and other VOCs present at the Southwest Plume source areas is potentially effective for removal of VOCs from extracted air; however, technical implementability and commercial availability are uncertain. This technology is retained for further evaluation.

Granular-Activated Carbon (Liquid Phase). GAC also is widely used for removal of VOCs including VOCs from aqueous streams, including pump-and treat systems. Liquid-phase carbon adsorption removes dissolved pollutants by physical adsorption onto activated carbon grains, similar to gas-phase adsorption as described previously. Sizing of the GAC bed is done based on effluent flow rate, face velocity and residence time. Most GAC systems include a multiple bed configuration to optimize carbon utilization. To meet state and federal emission standards, it may be necessary to monitor the effluent prior to release to the environment. GAC currently is used as a polishing step after air stripping at the PGDP Northwest Plume Pump-and-Treat Facility.

GAC is effective, technically implementable, and commercially available for removal of VOCs from extracted groundwater. This technology is retained for further evaluation.

### **Thermal Technologies**

Catalytic Oxidation. Oxidation equipment (thermal or catalytic) can be used for destroying contaminants in the exhaust gas from air strippers and SVE systems. Thermal oxidation units typically are single chamber, refractory-lined oxidizers equipped with a propane or natural gas burner and a stack. Lightweight ceramic blanket refractory is used because many of these units are mounted on skids or trailers. Flame arrestors are installed between the vapor source and the thermal oxidizer. Burner capacities in the combustion chamber range from 0.5 to 2 million BTUs per hour. Operating temperatures range from 760° to 870 °C (1,400 °F to 1,600 °F), and gas residence times typically are one second or less.

Catalytic oxidation includes a catalyst bed which accelerates the rate of oxidation by adsorbing the oxygen and the contaminant on the catalyst surface where they react to form carbon dioxide, water, and hydrochloric acid gas. The catalyst enables the oxidation reaction to occur at much lower temperatures than required by a conventional thermal oxidation. VOCs are thermally destroyed at temperatures typically ranging from 320° to 540 °C (600° to 1,000 °F) by using a solid catalyst. First, the contaminated air is directly preheated (electrically or, more frequently, using natural gas or propane) to reach a temperature necessary to initiate the catalytic oxidation [310 °C to 370 °C (600 °F to 700 °F)] of the VOCs. Then the preheated VOC-laden air is passed through a bed of solid catalysts where the VOCs are

rapidly oxidized. High chloride concentrations may require modification of the process to avoid corrosion.

Catalytic oxidation units are widely used for the destruction of VOCs and numerous vendors are available. As with the GAC absorption units, it may be necessary to monitor effluent concentrations to determine compliance with state and federal emission standards.

Catalytic oxidation is effective, technically implementable, and commercially available for removal of VOCs from extracted groundwater. This technology is retained for further evaluation.

Thermal Desorption. Thermal desorption heats wastes *ex situ* to volatilize water and organic contaminants. A carrier gas or vacuum system transports volatilized water and organics to a gas treatment system where they are collected or oxidized to CO<sub>2</sub> and water (FRTR 2008).

Two common thermal desorption designs are the rotary dryer and thermal screw. Rotary dryers are horizontal cylinders that can be indirect- or direct-fired. The dryer is normally inclined and rotated. Thermal screw units transport the medium through an enclosed trough using screw conveyors or hollow augers. Hot oil or steam circulates through the auger to indirectly heat the medium.

Thermal desorption systems typically require treatment of the off-gas to remove particulates and destroy contaminants. Particulates are removed by conventional particulate removal equipment such as wet scrubbers or fabric filters. Contaminants may be removed through condensation followed by carbon adsorption or destroyed in a secondary combustion chamber or a catalytic oxidizer.

Thermal desorption processes can be categorized into two groups based on operating temperatures, high temperature thermal desorption (HTTD), and low temperature thermal desorption (LTTD). HTTD heats wastes to 320° to 560 °C (600° to 1,000 °F) and is frequently used in combination with incineration, solidification/stabilization, or dechlorination, depending upon site-specific conditions. The technology can produce a final contaminant concentration level below 5 mg/kg for the target contaminants identified.

LTTD heats wastes to between 90° and 320 °C (200° to 600 °F). Contaminant destruction efficiencies in the afterburners of these units are greater than 95%. Decontaminated soil retains its physical properties. Unless heated to the higher end of the LTTD temperature range, soil organic matter remains available to support future biological activity. The target contaminant groups for LTTD systems are nonhalogenated VOCs and fuels. The technology can be used to treat SVOCs at reduced effectiveness.

The target contaminants for HTTD are SVOCs, polyaromatic hydrocarbons, PCBs, and pesticides. VOCs and fuels also may be treated, but treatment may be less cost-effective. Volatile metals may be removed by HTTD systems. The presence of chlorine can affect the volatilization of some metals, such as lead.

The following factors may limit the applicability and effectiveness of the process:

- Particle size and materials handling requirements can affect applicability or cost at specific sites;
- Dewatering may be necessary to achieve acceptable soil moisture content levels;
- Highly abrasive feed potentially can damage the processor unit;
- Heavy metals in the feed may produce a treated solid residue that requires stabilization; and

- Clay and silty soils and high humic content soils increase reaction time as a result of binding of contaminants.

In addition to identifying soil contaminants and their concentrations, information necessary for engineering thermal systems to specific applications include soil moisture content and classification, determination of boiling points for various compounds to be removed, and treatability tests to determine the efficiency of thermal desorption for removing various contaminants at various temperatures and residence times. A sieve analysis is needed to determine the dust loading in the system to properly design and size the air pollution control equipment.

Most of the hardware components for thermal desorption systems are readily available off the shelf. Most *ex situ* soil thermal treatment systems employ similar feed systems consisting of a screening device to separate and remove materials greater than five centimeters (2 inches), a belt conveyor to move the screened soil from the screen to the first thermal treatment chamber, and a weight belt to measure soil mass. Occasionally, augers are used rather than belt conveyors, but either type of system requires daily maintenance and is subject to failures that can shut down the system. Soil conveyors in large systems seem more prone to failure than those in smaller systems. Size reduction equipment can be incorporated into the feed system, but its installation is usually avoided to minimize shutdown as a result of equipment failure.

Many vendors offer LTTD units mounted on a single trailer. Soil throughput rates typically are 13 to 18 metric tons (15 to 20 tons) per hour for sandy soils and less than 6 metric tons (7 tons) per hour for clay soils when more than 10% of the material passes a 200-mesh screen. Units with capacities ranging from 23 to 46 metric tons (25 to 50 tons) per hour require four or five trailers for transport and two days for setup. The approximate time to complete cleanup of a 20,000-ton site using HTTD is just over four months.

Soil storage piles and feed equipment generally are covered as protection from rain to minimize soil moisture content and material handling problems. Soils and sediments with water contents greater than 20% to 25% may require the installation of a dryer in the feed system to increase the throughput of the desorber and to facilitate the conveying of the feed to the desorber. Some volatilization of contaminants occurs in the dryer, and the gases are routed to a thermal treatment chamber (FRTR 2008).

Thermal desorption is potentially effective, technically implementable, and commercially available for *ex situ* removal of VOCs from soil. This technology is retained for further evaluation.

#### **2.4.1.8 Disposal technologies**

Disposal technologies for recovered soil, groundwater, DNAPL, and secondary wastes produced during recovery and treatment are discussed below.

Land Disposal. Some of the treatment and removal technologies described previously would generate solid waste. RCRA hazardous wastes could be treated on-site to remove the hazardous characteristics or sent to EnergySolutions in Utah for treatment and disposal. Low-level radioactive waste or mixed low-level waste could be disposed of at sites such as Envirocare in Utah or the Nevada Test Site in Nevada. Nonhazardous soils or debris could be disposed of at the existing PGDP C-746-U Landfill if the waste acceptance criteria (WAC) were met, returned to the excavation, or otherwise used as fill.

Discharge to Groundwater or Surface Water. All operational wastewater is expected to be treated and used to control electrode conductivity. If excess operational wastewater is generated, it will be treated to

meet ARARs in a CERCLA treatment unit prior to being discharged. GAC beds could be returned to the manufacturer for thermal regeneration and reused.

It is reasonably expected that the Southwest Plume project effluent will meet all ambient water quality criteria (AWQC) in the receiving stream if the concentration of TCE and the specified degradation products are at or below the Kentucky numeric water quality criteria for fish consumption specified in Table I of 401 KAR 10:031 Section 6(1). There are no waste load allocations approved by EPA pursuant to 40 CFR § 130.7 for the receiving stream (Bayou Creek) that would impact effluent limits based on the numeric water quality criteria for fish consumption specified in Table I of 401 KAR 10:031 Section 6(1).

#### **2.4.2 Evaluation of Technologies and Selection of Representative Technologies**

Technologies retained following the initial screening in Section 2.4.1 are evaluated with respect to effectiveness, implementability, and relative cost in Table A.2 (see Appendix A). The objective of this evaluation is to provide sufficient information for subsequent selection of RPOs in Section 2.4.3. No technologies are screened out at this stage.

Effectiveness is the most important criterion at this evaluation stage. The evaluation of effectiveness was based primarily on the following:

- The potential effectiveness of process options in handling the estimated areas or volumes of contaminated media and meeting the RAOs;
- The potential impacts to worker safety, human health, and the environment during construction and implementation; and
- The degree to which the processes are proven and reliable with respect to the contaminants and conditions at the site.

The evaluation of implementability includes consideration of the following:

- The availability of necessary resources, skilled workers, and equipment to implement the technology;
- The availability of treatment, storage, and disposal services, including capacity;
- Site accessibility and interfering infrastructure;
- Potential public concerns regarding implementation of the technology; and
- The time and cost-effectiveness of implementing the technology in the physical setting associated with the waste unit.

A relative cost evaluation is provided for comparison among technologies. Relative capital and O&M costs are described as high, medium, or low. These costs are based on references applicable to the particular process option given at the end of this section, prior estimates, previous experience, and engineering judgment. The costs are not intended for budgeting purposes.

### 2.4.3 Representative Process Options

RPOs selected are listed in Table 2.5, based on the evaluation of process options for VOCs in UCRS soils at the Oil Landfarm and the C-720 Northeast and Southeast Sites. The RPOs selected were determined to be the most potentially effective and implementable and have the lowest cost of the process options considered for each technology type. The RPOs selected were used to develop the alternatives presented in Section 3.

Technologies that are identified by EPA as presumptive remedies (i.e., multiphase extraction for removal of VOCs in soil) are favored. Technologies that have been demonstrated at the PGDP for treatment of DNAPL TCE in the UCRS, including ERH and electrokinetics using Lasagna™, have higher demonstrated effectiveness and implementability than other technologies within the same technology type and also are preferred.

The RPOs selected also were determined to most effectively meet the RAOs for all phases of VOCs potentially present at the Oil Landfarm and the C-720 Northeast and Southeast Sites, as discussed in Section 1. These may include DNAPL TCE and VOCs sorbed to soil solids, dissolved in pore water and present as vapor in pore space. RPO selection also was based on the potential effectiveness and technical implementability in variable saturation in the UCRS, as described in Section 1.

Existing conditions and operations in the Southwest Plume source areas also were considered in RPO selection. Considerations included the ability to allow for ongoing operations in and around the C-720 Building, ability to be implemented in areas with surface and subsurface infrastructure, and minimal effects on existing site uses. Use of existing infrastructure or programs (e.g., the C-746-U Landfill, existing DOE plant controls, and discharges to permitted outfalls) were also favored.

RPO selection also was based on consideration of the fate of co-contaminants including Tc-99 in groundwater; SVOCs including PCBs and dioxin; radionuclides including uranium and Tc-99; and metals in the Oil Landfarm soil; during implementation of the technology. Considerations included the potential to increase the toxicity or mobility of co-contaminants, or to increase the volume of contaminated media. Selection of treatment and disposal RPOs also considered the technical and administrative feasibility of meeting discharge limits for effluents or disposal criteria for secondary wastes for these contaminants.

In some cases, more than one process option was selected for a technology type, for example, if two or more process options were considered to be sufficiently different in their performance that one would not adequately represent the other, or if the processes are complementary or part of a treatment train. Innovative technologies were selected as RPOs only if they were judged to provide better treatment, fewer or lower adverse effects, implementable within a reasonable time period, or lower costs than other established process options.

The initial selection of RPOs may be revised in the ROD based on public comment on the Proposed Plan, a successful treatability study or pilot demonstration, or other considerations.

**Table 2.5. Selection of Representative Process Options**

<b>General Response Actions</b>	<b>Technology Type</b>	<b>Representative Process Options</b>	<b>Basis for Selection</b>
LUCs	Institutional controls	Excavation/Penetration Permit program	Effective and implementable for worker protection; low cost.
	Physical controls	Warning signs	Effective and implementable for worker protection; low cost.
Monitoring	Soil monitoring	Soil cores	Effective and implementable for confirmatory sampling; moderate cost.
		Soil vapor sampling	Effective and implementable for monitoring; low cost.
		Membrane interface probe	Effective and implementable for monitoring decreases in constituents; moderate cost.
	Groundwater monitoring	Sampling and analysis	Effective and implementable for monitoring; moderate to high cost.
		DNAPL interface probe	Effective and implementable for DNAPL detection in groundwater monitoring wells; low cost.
Removal	Excavators	Large Diameter Auger	Effective in alluvial soils to depths greater than 27.4 m (90 ft) bgs; technically implementable; high cost.
		Vacuum excavation	Demonstrated effectiveness in alluvial soils to depths of 10.4 m (34 ft) bgs; technically implementable; moderate costs.
Containment	Surface barriers	Conventional asphalt cover	Effective and implementable, trafficable surface, can be installed around infrastructure; low cost.

**Table 2.5. Selection of Representative Process Option (Continued)**

<b>General Response Actions</b>	<b>Technology Type</b>	<b>Representative Process Options</b>	<b>Basis for Selection</b>
Treatment	Physical/chemical	Multiphase extraction- <i>in situ</i>	Presumptive remedy for all VOC phases in UCRS; effective and implementable in variably saturated soils; moderate cost.
		Air stripping- <i>ex situ</i>	Effective and implementable for <i>ex situ</i> removal of TCE from groundwater; low cost; currently implemented at Northwest Plume treatment plant.
		Ion exchange- <i>ex situ</i>	Effective and implementable for <i>ex situ</i> removal of Tc-99 from groundwater; moderate cost; currently implemented at Northwest Plume treatment plant.
		Soil mixing- <i>in situ</i>	Potentially effective and implementable for all VOC phases in UCRS at PGDP; effective and implementable in variably saturated soils; moderate cost.
	Biological	Anaerobic reductive dechlorination- <i>in situ</i>	Potentially effective and implementable for all VOC phases in UCRS; less effective in variably saturated soils, low permeability; relatively low cost.
	Thermal	Electrical resistance heating- <i>in situ</i>	Demonstrated effectiveness and implementability for all VOC phases in UCRS at PGDP; effective and implementable in variably saturated soils; very high cost.
		Thermal desorption- <i>ex situ</i>	Effective and implementable for all VOC phases as an adjunct technology for soil removal; high cost.
		Catalytic oxidation- <i>ex situ</i>	Effective and implementable treatment for thermal desorption, SVE or air stripper off-gas; high cost.

**Table 2.5. Selection of Representative Process Option (Continued)**

<b>General Response Actions</b>	<b>Technology Type</b>	<b>Representative Process Options</b>	<b>Basis for Selection</b>
Disposal	Land Disposal	Off-site permitted commercial disposal facility	Effective and implementable as an adjunct technology for soil removal; high cost.
		C-746-U on-site landfill	Effective and implementable for nonhazardous nonradioactive wastes, currently available; low cost.
	Discharge to surface water	Existing surface water outfalls	Effective and implementable for treated groundwater; low costs; currently implemented at Northwest Plume treatment plant.

DOE = U.S. Department of Energy

DNAPL = dense nonaqueous-phase liquid

KPDES = Kentucky Pollutant Discharge Elimination System

SVE = soil vapor extraction

Tc-99 = technetium-99

TCE = trichloroethene

UCRS = Upper Continental Recharge System

VOC = volatile organic compound



**THIS PAGE INTENTIONALLY LEFT BLANK**

## **3. DEVELOPMENT AND SCREENING OF ALTERNATIVES**

### **3.1 INTRODUCTION**

The alternatives presented in the following sections were developed by combining the RPOs identified in Section 2.4 into a range of treatment strategies to meet the RAOs. The alternatives were formulated to create responses that vary in their extent of attainment of RAOs, effectiveness, implementability, and cost in order to meet EPA's expectation that the feasibility studies for source control actions provide "A range of alternatives in which treatment that reduces the toxicity, mobility, or volume of the hazardous substances, pollutants, or contaminants is a principal element" [40 *CFR* § 300.430(e)(3)(i)].

Also, the demonstrated effectiveness of combined technologies (e.g., soil flushing and multiphase extraction) was used to identify appropriate comprehensive alternatives. Media interactions including effects of source actions on RGA groundwater during implementation also were considered.

Alternatives are developed and discussed based on the applicability to each individual site. Due to dissimilarities in conditions at the Oil Landfarm and C-720 Sites, certain alternatives are developed for the Oil Landfarm, but not the C-720 Sites and vice versa. The C-720 Sites are discussed with the assumption that the same alternative would be applied to the Northeast and Southeast Sites. This assumption is based on the analogous conditions found at both sites.

### **3.2 CRITERIA FOR THE DEVELOPMENT OF REMEDIAL ALTERNATIVES**

The purpose of the FFS and the overall remedy selection process is to identify remedial actions that eliminate, reduce, or control risks to human health and the environment and meet ARARs. The national program goal of the FS process, as defined in the NCP, is to select remedies that are protective of human health and the environment, that maintain protection over time, and that minimize untreated waste. The NCP defines certain expectations for developing remedial action alternatives to achieve these goals, stated in 40 *CFR* § 300.430. These expectations were used to guide the development of alternatives, discussed below.

### **3.3 ARARS**

Section 121(d) of CERCLA and Section 300.430(f)(1)(ii)(B) of the NCP require that remedial actions at CERCLA sites at least attain legally "applicable" or "relevant and appropriate" federal and state environmental requirements, standards, criteria, and limitations, unless such ARARs are waived under CERCLA Section 121(d)(4).

Chemical-specific ARARs provide health- or risk-based concentration limits or discharge limitations in various environmental media (i.e., surface water, groundwater, soil, or air) for specific hazardous substances, pollutants, or contaminants. There are no chemical-specific ARARs for remediation of the contaminated subsurface soils at the source areas; however, Kentucky drinking water standard MCLs at 401 *KAR* 8:420 for VOCs were used for calculation of soil RGs to meet RAO #3.

Location-specific ARARs establish restrictions on permissible concentrations of hazardous substances or establish requirements for how activities will be conducted because they are in special locations (e.g., floodplains or historic districts). Action-specific ARARs include operation, performance, and design of the preferred alternative based on waste types and/or media to be addressed and removal/remedial

activities to be implemented. Location- and action-specific ARARs have been identified and evaluated for each alternative in Section 4.

### **3.4 DEVELOPMENT OF ALTERNATIVES**

The RPOs selected in Section 2.4.3 were combined to formulate a range of comprehensive remedial alternatives to satisfy the NCP expectations and the RAOs for the Oil Landfarm and the C-720 Northeast and Southeast Sites. Alternatives are summarized in Table 3.1. Effectiveness, implementability, and cost are criteria used to guide the development and screening of remedial alternatives.

Conceptual designs are developed for each alternative with sufficient detail to allow for detailed and comparative analysis, and cost estimating with a -30% to +50% range of accuracy, per CERCLA guidance (EPA 1988). Implementation procedures and operations, monitoring, and maintenance requirements are discussed. Supporting calculations and cost estimates for the conceptual designs are provided in Appendix B.

#### **3.4.1 Alternative 1—No Further Action**

Formulation of a no-action alternative is required by the NCP [40 *CFR* § 300.430(e)(6)] and CERCLA FS guidance (EPA 1988). The no-action alternative serves as a baseline for evaluation of other remedial action alternatives and is generally retained throughout the FS process. As defined in CERCLA guidance (EPA 1988), a no-action alternative may include environmental monitoring; however, other actions taken to reduce exposure, such as site fencing are not included as a component of the no-action alternative. Alternative 1, therefore, includes no actions and no costs.

#### **3.4.2 Alternative 2—Long-Term Monitoring with Interim LUCs**

Alternative 2 consists of the following:

- Groundwater monitoring
- Interim LUCs (i.e., warning signs and E/PP program)
- Five-year reviews

Alternative 2 consists of a combination of interim LUCs and groundwater monitoring in the RGA. This alternative does not provide treatment or removal of VOC contamination in the UCRS and would not prevent the completion of exposure pathways shown in Figure 1.19. Alternative 2 would institute the restrictions associated with the E/PP program and physical controls such as warning signs. These interim LUCs would prevent the completion of the worker exposure pathways. RGA groundwater monitoring wells would be installed, as necessary, at the downgradient edge of the source areas to monitor TCE concentrations attributed to contamination leaching from the UCRS into the RGA. A schematic view of the conceptual design is provided in Figure 3.1, and a plan view of potential MW locations and other physical controls at the Oil Landfarm and C-720 Northeast and Southeast Sites are shown in Figures 3.2 and 3.3, respectively.

Natural attenuation processes (e.g., degradation, migration, and dispersion) are expected to have some impact on VOC contamination in the UCRS. Both aerobic and anaerobic conditions are most likely found in the UCRS. This microbiology is confirmed by the presence of TCE degradation products, which are largely a result of natural biodegradation.

Table 3.1. Alternative Formulation for the Oil Landfarm and the C-720 Northeast and Southeast Sites

Alternative 1	Alternative 2	Alternative 3	Alternative 4	Alternative 5	Alternative 6	Alternative 7	Alternative 8
No further action	Long term monitoring with interim LUCs	<i>In situ</i> source treatment using deep soil mixing with interim LUCs	Source removal and <i>in situ</i> chemical source treatment with interim LUCs	<i>In situ</i> thermal source treatment with interim LUCs	<i>In situ</i> source treatment using LAI with interim LUCs	<i>In situ</i> soil flushing and source treatment using multiphase extraction with interim LUCs	<i>In situ</i> source treatment using EISB with interim LUCs
	<ul style="list-style-type: none"> <li>Groundwater monitoring</li> <li>Secondary waste management</li> <li>Interim LUCs</li> <li>Five-year reviews</li> </ul>	<ul style="list-style-type: none"> <li>RDSI</li> <li>Injection and mixing of reagent</li> <li>Confirmatory Sampling</li> <li>Secondary waste management</li> <li>Site restoration</li> <li>Groundwater monitoring</li> <li>Interim LUCs</li> <li>Five-year reviews</li> </ul>	<ul style="list-style-type: none"> <li>RDSI</li> <li>LDA excavation</li> <li>Waste management and disposal</li> <li>Treatment</li> <li>Confirmatory sampling</li> <li>Site restoration</li> <li>Groundwater monitoring</li> <li>Interim LUCs</li> <li>Five-year reviews</li> </ul>	<ul style="list-style-type: none"> <li>RDSI</li> <li>Treatment using ERH with vapor extraction</li> <li>Off-gas treatment</li> <li>Process monitoring</li> <li>Confirmation sampling</li> <li>Secondary waste management</li> <li>Site restoration</li> <li>Groundwater monitoring</li> <li>Interim LUCs</li> <li>Five-year reviews</li> </ul>	<ul style="list-style-type: none"> <li>RDSI</li> <li>Injection of a reagent using LAI</li> <li>Secondary waste management</li> <li>Confirmatory Sampling</li> <li>Site restoration</li> <li>Groundwater monitoring</li> <li>Interim LUCs</li> <li>Five-year reviews</li> </ul>	<ul style="list-style-type: none"> <li>RDSI</li> <li>Surfactant-enhanced soil flushing</li> <li>Multiphase extraction</li> <li>Off-gas treatment</li> <li>Co-produced groundwater treatment</li> <li>Sampling and monitoring</li> <li>O&amp;M</li> <li>Confirmation sampling</li> <li>Secondary waste management</li> <li>Site restoration</li> <li>Interim LUCs</li> <li>Five-year reviews</li> </ul>	<ul style="list-style-type: none"> <li>RDSI</li> <li>Installation of gravity feed EISB system</li> <li>Introduction of bioamendment</li> <li>Confirmatory Sampling</li> <li>Secondary Waste Management</li> <li>Site restoration</li> <li>Interim LUCs</li> <li>Groundwater monitoring</li> <li>Five-year reviews</li> </ul>

Note: LUCs include the E/PP program and warning signs.  
 E/PP program = excavation/penetration permit program  
 EISB – Enhanced *in situ* bioremediation

ERH = electrical resistance heating  
 LAI = liquid atomized injection  
 LDA = large diameter auger

LUC = land use control  
 O&M = operation and maintenance  
 RDSI = remedial design site investigation

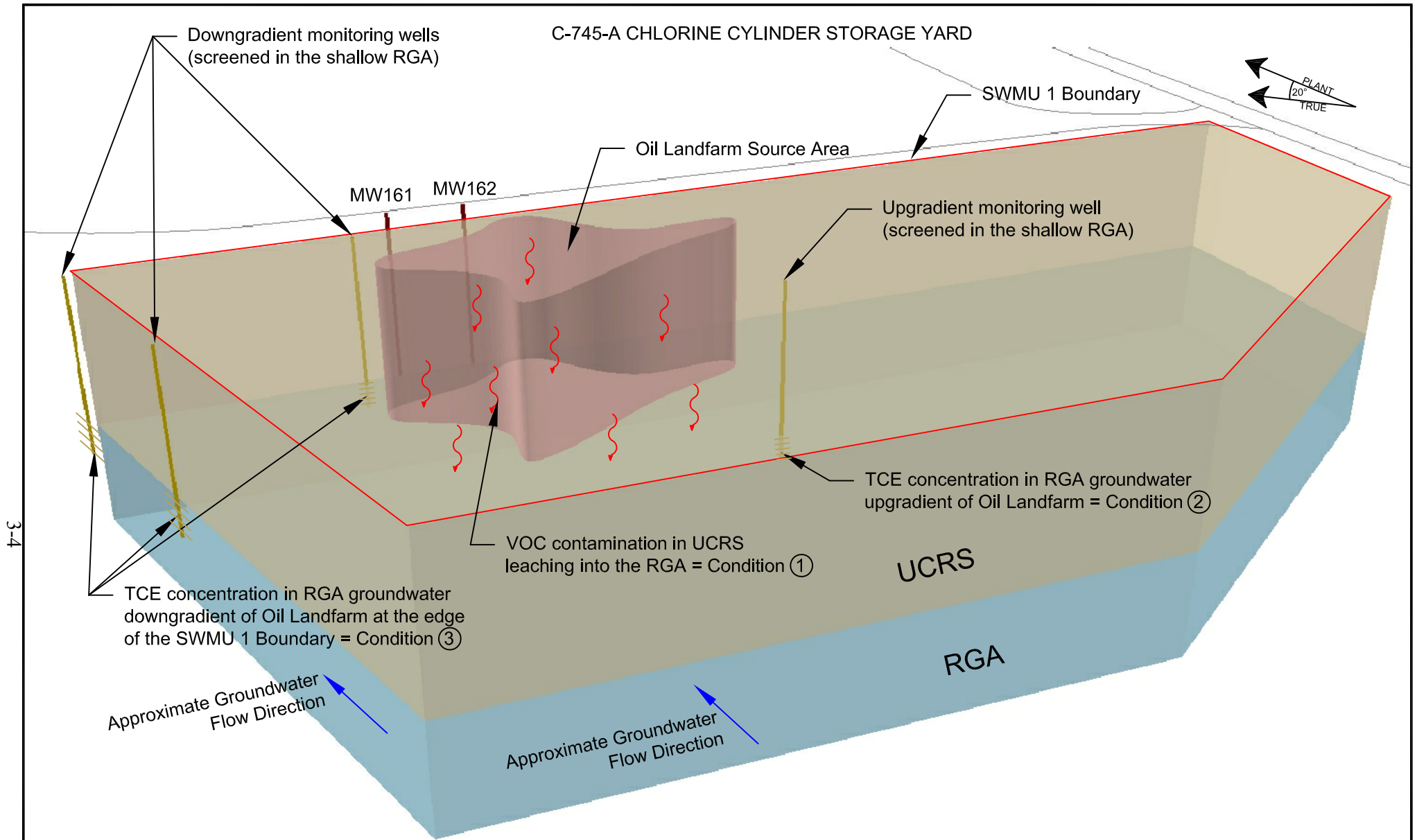

Condition ① contributes to TCE concentrations found in downgradient wells (Condition ③), but not to TCE concentrations found in upgradient wells (Condition ②).

Monitoring wells would be sampled on a long-term basis as long as:

② - ③ > TCE MCL (5 µg/L)

 LATA Environmental Services of Kentucky, LLC	U.S. DEPARTMENT OF ENERGY DOE PORTSMOUTH/PADUCAH PROJECT OFFICE PADUCAH GASEOUS DIFFUSION PLANT		
<b>Figure 3.1.</b> <b>Schematic View of Alternative 2 – Long-term Monitoring with Interim Land Use Controls at the Oil Landfarm Site</b>			
FILE NAME: SWMU-XSECTION_RGA	PROJECT #: 11105	SCALE: AS NOTED	DATE: 11/23/2010

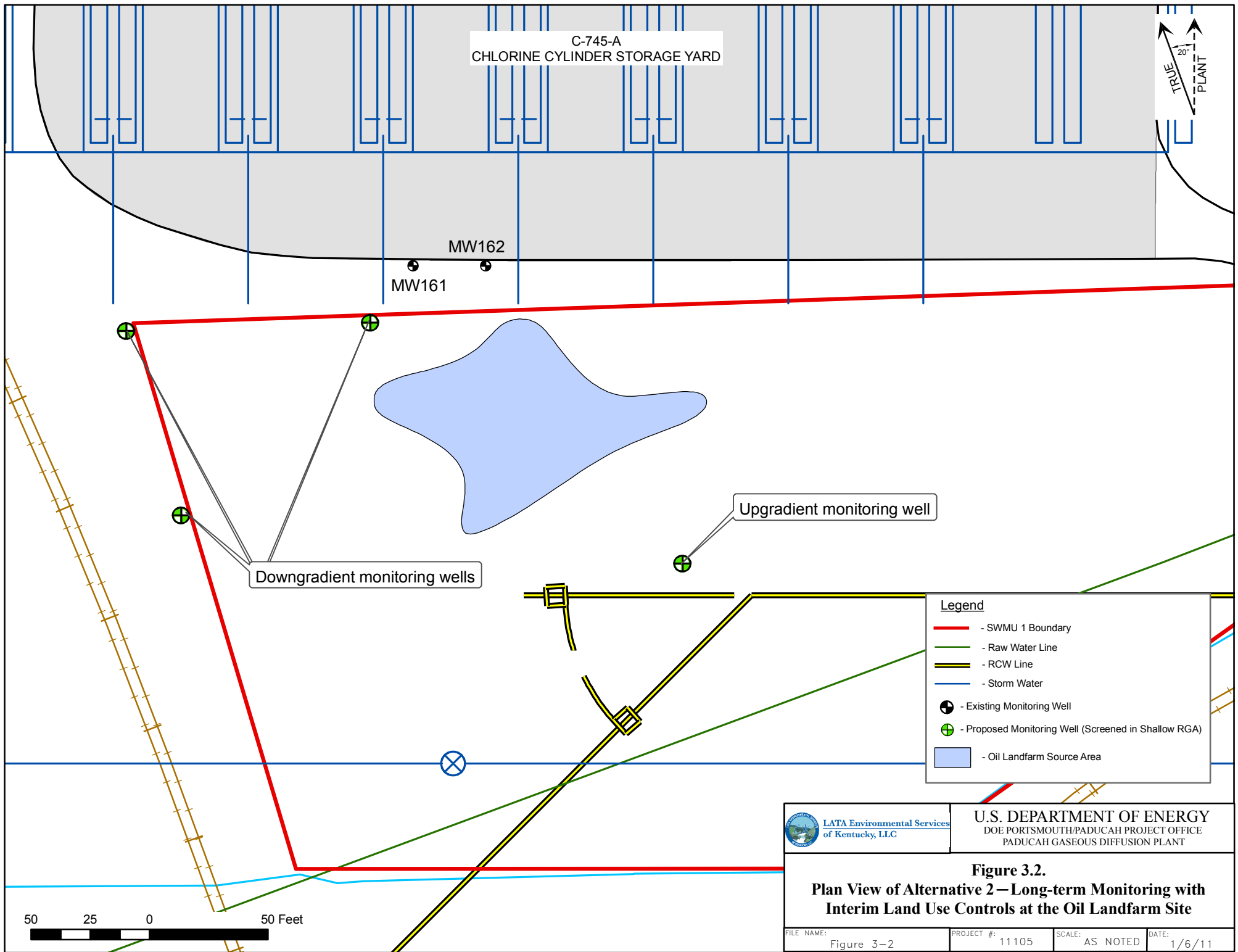

C-745-A  
CHLORINE CYLINDER STORAGE YARD

MW162  
MW161

TRUE  
PLANT  
20°

Downgradient monitoring wells

Upgradient monitoring well

**Legend**

- SWMU 1 Boundary
- Raw Water Line
- RCW Line
- Storm Water
- Existing Monitoring Well
- Proposed Monitoring Well (Screened in Shallow RGA)
- Oil Landfarm Source Area

LATA Environmental Services  
of Kentucky, LLC

U.S. DEPARTMENT OF ENERGY  
DOE PORTSMOUTH/PADUCAH PROJECT OFFICE  
PADUCAH GASEOUS DIFFUSION PLANT

**Figure 3.2.**  
**Plan View of Alternative 2 – Long-term Monitoring with Interim Land Use Controls at the Oil Landfarm Site**

50 25 0 50 Feet

FILE NAME: Figure 3-2 PROJECT #: 11105 SCALE: AS NOTED DATE: 1/6/11

3-5

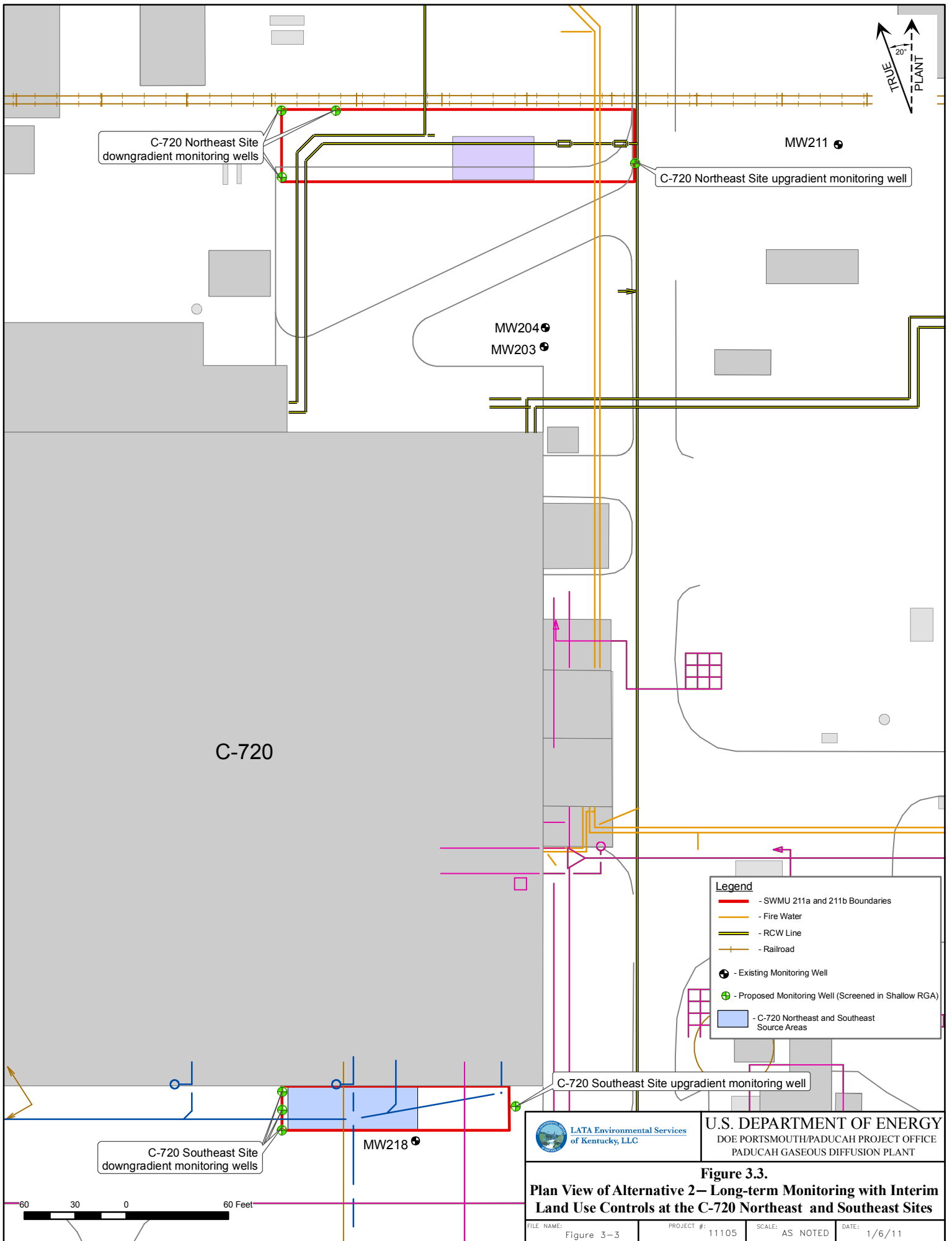

### **3.4.2.1 Groundwater monitoring**

Groundwater monitoring would be used to determine the rates of contaminants migrating from the UCRS to the RGA. One upgradient and three downgradient wells, screened in the shallow RGA, would be constructed at each source area. Wells would be monitored for VOCs and water levels at a frequency to be determined. Groundwater monitoring requirements would be included in the RAWP. Results would be reported as part of the five-year reviews and provided to the sitewide environmental monitoring program and to the Dissolved-Phase Plumes Remedial Action Project under the Groundwater OU. Monitoring wells would remain in place until soil RGs were attained.

### **3.4.2.2 Secondary waste management**

Secondary wastes would include drill cuttings (produced during installation of monitoring wells), personal protective equipment (PPE), and decontamination fluids. For cost-estimating purposes these wastes were assumed to require containerization, dewatering, and testing prior to off-site disposal. Actual dispositioning requirements would be determined by sampling of containerized soils. All secondary wastes would be managed in accordance with all ARARs.

### **3.4.2.3 Interim LUCs**

The interim LUCs for this action are warning signs and the existing E/PP program. The E/PP program identifies and controls potential personnel hazards related to trenching, excavation, and penetration greater than 6 inches. Warning signs will be placed at the facilities to provide notification of contamination. Both interim LUCs will remain in place pending remedy selection as part of subsequent OUs that addresses relevant media.

### **3.4.2.4 Five-year reviews**

Five-year reviews would be required under the FFA as long as soil contaminant concentrations remained above RGs. A review would be submitted to EPA and Kentucky Energy and Environment Cabinet no less often than once every five years after the initiation of the remedial action for as long as PGDP remained on the NPL to assure that human health and the environment are protected by the remedial action being implemented. Groundwater monitoring results would be summarized in the report.

## **3.4.3 Alternative 3—*In situ* Source Treatment Using Deep Soil Mixing with Interim LUCs**

Alternative 3 consists of the following:

- RDSI investigation to refine the extent of VOC contamination and determine *in situ* parameters related to the injected reagent
- Injection and mixing of a reagent (i.e., oxidant, or ZVI) into the UCRS from approximately 15 ft bgs to the lowest depth of VOC contamination
- Confirmatory sampling
- Secondary waste management
- Site restoration
- Groundwater monitoring



- Interim LUCs (i.e., warning signs and E/PP program)
- Five-year reviews

This alternative would reduce the mass of VOCs present in the source areas and eliminate risks to receptors by eliminating the exposure pathways shown in Figure 1.19. Deep soil mixing is evaluated for potential implementation at the Oil Landfarm. This alternative is not feasible at the C-720 Northeast and Southeast Sites due to the high risk of damaging utilities present in the subsurface. Requirements and conceptual designs for each element of Alternative 3 are discussed below in detail. A schematic view of the conceptual design is provided in Figure 3.4, and a plan view of the Oil Landfarm area that would be treated is shown in Figure 3.5.

### **3.4.3.1 RDSI**

An RDSI would be performed at the Oil Landfarm to better determine the extent and distribution of VOCs, including DNAPL TCE, and to determine UCRS soil and groundwater parameters specific to the reagent being injected. The extent and distribution of VOCs in the UCRS would impact the spacing/locations and depths of the augered areas. The amount and type of reagent chosen would be based on RDSI sampling results. Based on the calculated RGs for VOC concentrations in source area soil presented in Section 2.2, the RDSI would include supplemental investigations to delineate the lateral and vertical extent of VOC contamination at the Oil Landfarm are described below.

Figure 1.20 shows the WAG 27 RI and Southwest Plume SI sampling locations and results for the Oil Landfarm. TCE at concentrations greater than the calculated RG is not bounded on the north, as evidenced by concentrations above the RG in WAG 27 boring 001-069. The TCE is not bounded vertically, as evidenced by concentrations above the RG detected at the maximum depths of borings in both investigations. SI boring 001-202 encountered TCE at 3,400 µg/kg at the maximum depth of 59.5 ft bgs. SI boring 001-204 encountered TCE at 290 µg/kg at the maximum depth of 58.5 ft bgs. Boring 001-201 encountered TCE at 1,800 µg/kg at 56.0 ft bgs.

The uppermost unit of the RGA, the HU4, occurs at approximately 53 ft bgs at the Oil Landfarm, as discussed in Section 1. The presence of TCE concentrations above RGs at depths greater than 53 ft bgs at the Oil Landfarm indicates that VOC contamination potentially including DNAPL has migrated to the upper RGA. The presence of TCE above RGs at maximum borehole depths of 56.5 ft bgs at the C-720 Northeast Site also indicates that VOC contamination potentially including DNAPL has migrated to the RGA. If the results of the RDSI indicate that DNAPL has migrated to the RGA at the Southwest Plume source areas, the scope of the source control actions, currently limited to the UCRS, may need to be extended to the RGA. Based on lessons learned from the C-400 Phase 1 project, it is understood that remedial actions intended to address DNAPL source material in the RGA include considerations that are separate and unique from the actions identified in this FFS to mitigate source material in the UCRS. The RGA is generally regarded as a transmissive aquifer; however, hydraulic properties are estimated to be somewhat variable based on recent flow model calibration results. Site-specific considerations in terms of hydraulic conductivity, flow velocity, and the distribution of potential source material will need to be characterized, and results from C-400 Phase 2 brought forward to ensure that, should an action be required for the RGA for the Southwest Plume sites, the appropriate technical approach for source material remediation is developed.

The RDSI would be based on a systematically planned approach developed in the Remedial Design (RD) Work Plan. Principal study questions to be resolved by the investigation would include the following:

**B**  
NORTHWEST  
ELEVATION  
(FT/AMSL)

**B'**  
NORTHEAST  
ELEVATION  
(FT/AMSL)

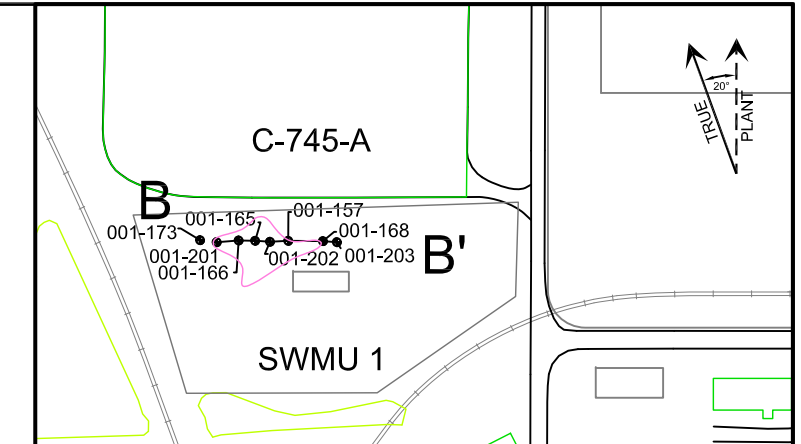
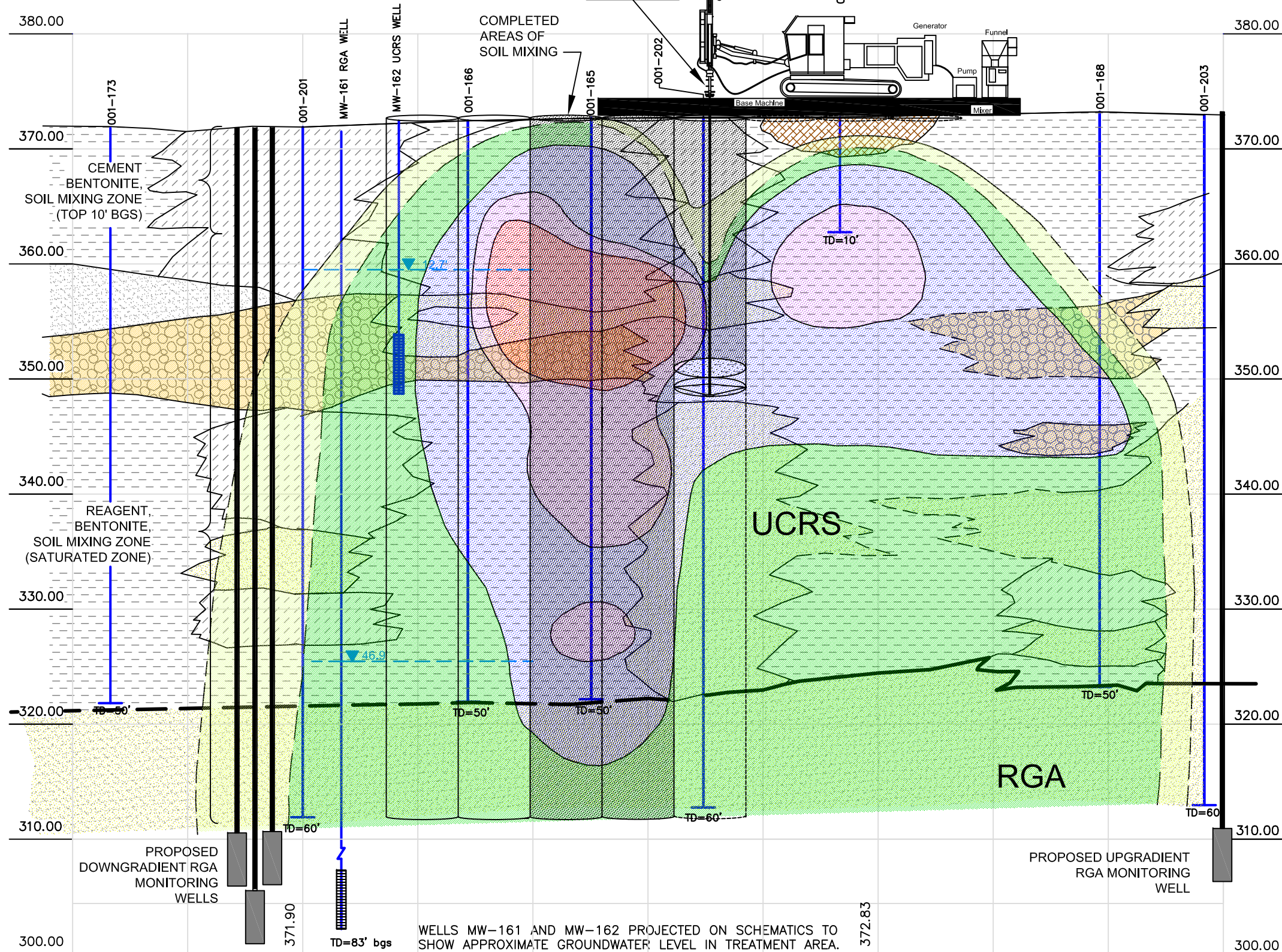

**LOCATION MAP**  
SCALE: 1" = 250'

**LEGEND**

- GRAVEL
- CLAY
- SAND
- SILT
- FILL
- PROPOSED RGA WELL SCREEN
- EXISTING RGA WELL SCREEN
- EXISTING UCRS WELL SCREEN
- DASHED WHERE INFERRED
- UCRS - UPPER CONTINENTAL RECHARGE SYSTEM
- RGA - REGIONAL GRAVEL AQUIFER
- WATER LEVEL AT TIME OF GEOPHYSICAL LOG

**TCE SOIL CONCENTRATION**

- 90 - 999 µg/kg
- 1000 - 9,999 µg/kg
- 10,000 - 49,000 µg/kg
- 50,000 - 99,999 µg/kg
- > 100,000 µg/kg symbol"/> > 100,000 µg/kg

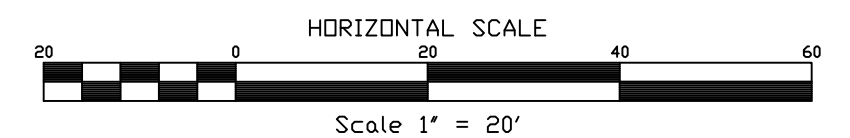
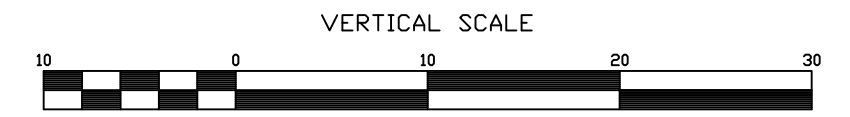

LATA Environmental Services of Kentucky, LLC	U.S. DEPARTMENT OF ENERGY DOE PORTSMOUTH/PADUCAH PROJECT OFFICE PADUCAH GASEOUS DIFFUSION PLANT
--	---

**Figure 3.4.**  
**Schematic View of Alternative 3 – *In situ* Source Treatment Using Deep Soil Mixing with Interim Land Use Controls**

FILE NAME: Fig 3-4	PROJECT #: 11105	SCALE: AS NOTED	DATE: 1/5/2011
--------------------	------------------	-----------------	----------------

**THIS PAGE INTENTIONALLY LEFT BLANK**

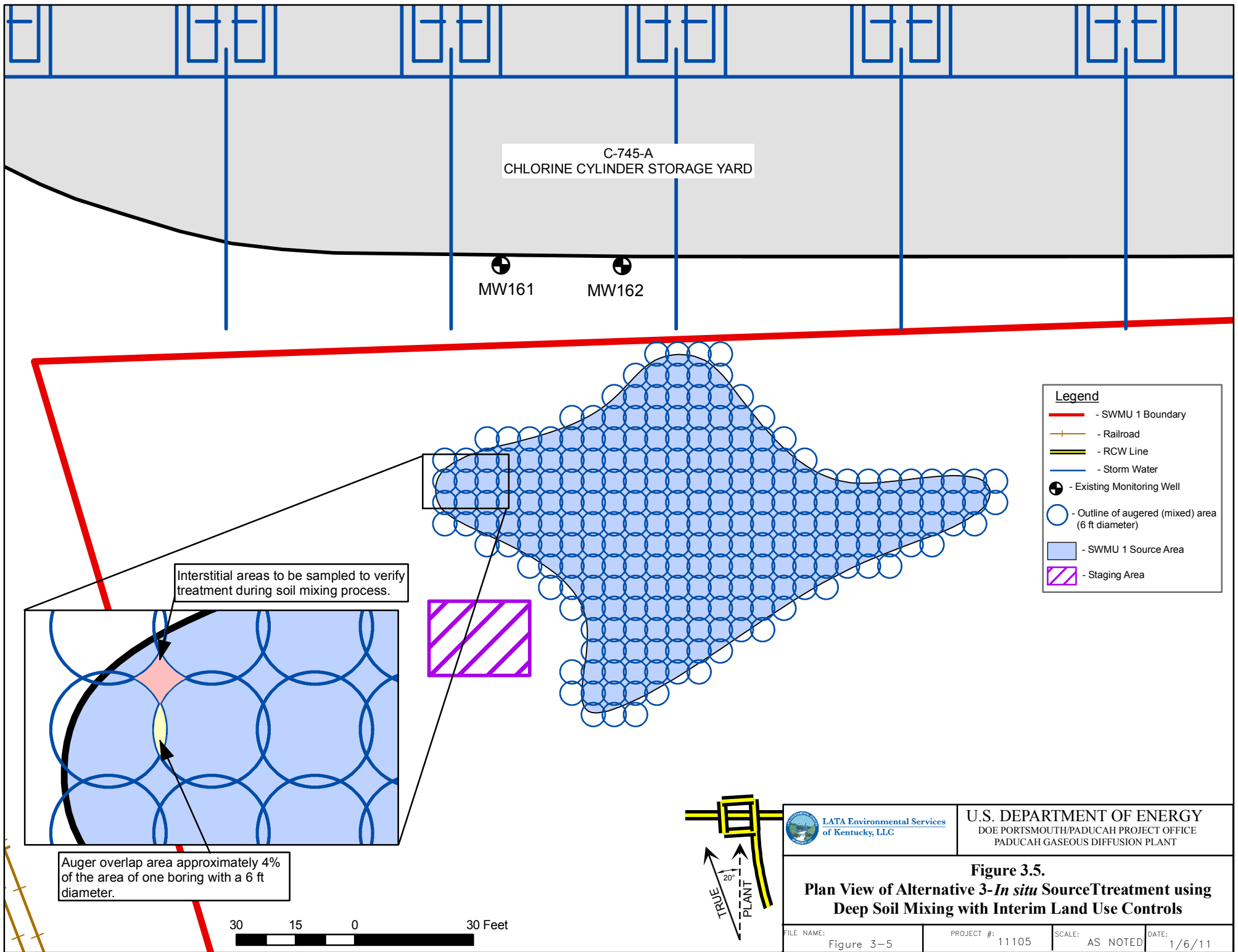

Interstitial areas to be sampled to verify treatment during soil mixing process.

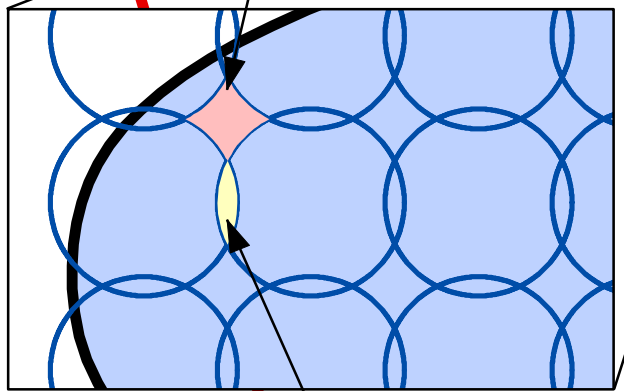

Auger overlap area approximately 4% of the area of one boring with a 6 ft diameter.

**Legend**

- - SWMU 1 Boundary
- + - Railroad
- - RCW Line
- - Storm Water
- - Existing Monitoring Well
- - Outline of augered (mixed) area (6 ft diameter)
- - SWMU 1 Source Area
- ▨ - Staging Area

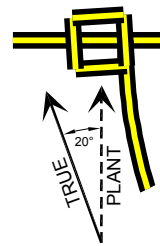

LATA Environmental Services  
of Kentucky, LLC

U.S. DEPARTMENT OF ENERGY  
DOE PORTSMOUTH/PADUCAH PROJECT OFFICE  
PADUCAH GASEOUS DIFFUSION PLANT

**Figure 3.5.**  
**Plan View of Alternative 3-*In situ* Source Treatment using Deep Soil Mixing with Interim Land Use Controls**

FILE NAME: Figure 3-5	PROJECT #: 11105	SCALE: AS NOTED	DATE: 1/6/11
--------------------------	---------------------	--------------------	-----------------

- (1) What are the areal and vertical extents of VOC contamination above RGs at the Southwest Plume Source Area sites?
- (2) Has DNAPL migrated to the RGA at the Southwest Plume Source Area sites?

The conceptual design for the RDSI includes the following:

- Preliminary soil gas sampling using the MIP and on-site analysis for VOCs at the Oil Landfarm to estimate the areal and vertical extents of contamination including DNAPL.
- Soil coring using DPT and analysis for VOCs using EPA SW-846 Method 8260B or equivalent at locations that have been identified using the MIP results. Soil cores also would be evaluated to determine the presence or absence of DNAPL.
- Sampling of existing UCRS wells in the vicinity of the source area and analysis for geochemical, contaminant, and reagent parameters.
- Civil survey of all sampling and well locations.

The primary design elements that would be taken into consideration if deep soil mixing were implemented at the Oil Landfarm include the following:

- The amount and type of reagent injected (i.e., oxidant or ZVI). Many options exist within each category of reagent (i.e., oxidants include chemical species such as permanganate, hydrogen peroxide, sodium persulfate, ozone, etc.).
- Locations and spacing of the borings.
- Permeability/stability of the source area following treatment.

#### **3.4.3.2 Injection and mixing of reagent**

Deep soil mixing would be performed using an LDA equipped with a hollow rotary kelly bar. A single auger mixing process is assumed for costing purposes. The diameter of the auger can range from 6 ft to 12 ft for this type of technology. At the Oil Landfarm, where an approximate depth of 60 ft would be required, a 6-ft diameter auger most likely would be used. As the auger is advanced into the soil, a slurry would be pumped through the hollow stem of the shaft and injected into the soil at the tip. The auger would be rotated and raised and the mixing blades on the shaft would blend the soil and the slurry. When the design depth is reached, the auger would be withdrawn, and the mixing process would be repeated on the way back to the surface. This mixing technique would be repeated, as necessary, in each boring.

Contaminated portions of the UCRS would be treated using a two-phase treatment process. In the first phase, a reagent slurry (for costing purposes, an iron filing, biopolymer guar, and water grout slurry is assumed) would be mixed in the soil columns, below 10 ft bgs. In the second phase, a bentonite and water solution would be mixed with the columns, below 10 ft bgs, to stabilize the mixing column and immobilize potential residual contamination. In addition, the top 10 ft bgs would be injected with a cement/bentonite slurry. The cement/bentonite mixture would stabilize, improve the strength of, and reduce the compressibility of the treated area. Variable amounts of infiltration would be expected, based on the final design of the cement cap. If no cement/grout mixture were injected, the surface likely would be unstable following treatment.

The locations and spacing of the mixed areas would depend on the areal and vertical extents of TCE contamination, as determined during the RDSI. For the purposes of this evaluation, a 4% overlap pattern was assumed for the detailed and comparative analyses. This pattern assumes that two adjacent borings would overlap by 4% of the area of one boring; therefore, if a boring is overlapped on four sides, a total of 16% overlap would be achieved. The boring overlap pattern is provided in Figure 3.5. A total depth of 60 ft for each boring also was assumed for this evaluation.

#### **3.4.3.3 Confirmatory sampling**

Confirmatory sampling in the treatment area would be required to determine posttreatment TCE soil concentrations. A confirmatory sampling plan would be prepared during RAWP development. The conceptual design for confirmatory sampling includes soil coring using DPT and analysis for VOCs using EPA SW-846 Method 8260B or equivalent. Depths and locations of cores would be determined based on the results of the RDSI.

#### **3.4.3.4 Secondary waste management**

The addition of material to the subsurface could cause expansion of *in situ* material during deep soil mixing. This expansion could result in the generation of secondary waste spoils (e.g., soil, reagent, grout, and water mixture). On average, the amount of spoils generated is approximately 30% of the volume of the treated column; however, up to 60% potentially could be generated. The amount of spoils depends on the components of the mixture being added and the soil matrix (e.g., deep soil mixing in a clay matrix is likely to result in more spoils than mixing in a sandy matrix). Soils and groundwater containing TCE are considered a RCRA listed hazardous waste until the materials can be further characterized. For costing purposes, it was assumed that all wastes would be managed as nonhazardous, because the TCE hazardous constituent would be treated during implementation of the remedial action. Actual disposal requirements would be determined by sampling of secondary wastes. If the waste was found to be hazardous, the associated increase in requirements for containerization and disposal would result in increased complexity and cost for implementation; however, this adjustment would not be expected to have a significant impact on the relative ranking of the alternatives, as discussed in Sections 4 and 5 of this FFS. All secondary wastes would be managed in accordance with ARARs.

#### **3.4.3.5 Site restoration**

Surface restoration following this remedial action would include placement of topsoil and vegetation at the Oil Landfarm. The site would be graded to promote runoff, and a land survey would be conducted to produce topographic as-built drawings.

#### **3.4.3.6 Groundwater monitoring**

Groundwater monitoring would be used to determine the effectiveness of the remedy. One upgradient and three downgradient wells, screened in the shallow RGA, would be constructed at each source area. Wells would be monitored for VOCs and water levels at a frequency to be determined. Groundwater monitoring requirements would be included in the RAWP. Results would be reported as part of the five-year reviews and provided to the sitewide environmental monitoring program and to the Dissolved-Phase Plumes Remedial Action Project under the Groundwater OU. MWs would remain in place until soil RGs were attained.

#### **3.4.3.7 Interim LUCs**

Interim LUCs (E/PP program and warning signs), as described for Alternative 2, would be implemented.

### 3.4.3.8 Five-year reviews

Five-year reviews, as described for Alternative 2, would be implemented as long as soil contaminant concentrations remained above RGs.

### 3.4.4 Alternative 4—Source Removal and *In situ* Chemical Source Treatment with Interim LUCs

Alternative 4 consists of the following:

- RDSI
- Excavating source area soils contaminated with VOCs above RGs
- Managing and disposing excavated soils
- Treating contaminated soils in the bottom 10–13 ft of the UCRS (excavation “buffer zone”) *in situ*
- Confirmatory sampling
- Site restoration
- Groundwater monitoring
- Interim LUCs (i.e., warning signs and E/PP program)
- Five-year reviews

This alternative would remove VOC mass in excavated areas and reduce VOC mass present in the bottom 10-13 ft of the UCRS (i.e., excavation “buffer zone”). VOC mass that would be removed or reduced would include PTW, in source areas in the UCRS. The alternative consists of excavation using an LDA combined with deep *in situ* treatment and interim LUCs. The general concept of the alternative is to excavate to the lowest depth possible, while avoiding up-welling of contaminated groundwater from the RGA and/or heaving of RGA material into the excavation due to differential lithostatic pressures. To prevent up-welling and/or heaving, an excavation buffer zone of approximately 10-13 ft would be maintained between the bottom of the completed borings and the top of the RGA potentiometric surface. The unexcavated material that composes the “buffer zone,” would be treated *in situ* with the addition of an amendment to reduce leaching of VOCs into the RGA.

Alternative 4 would eliminate VOCs present in all phases from the excavated area and reduce contamination present in the buffer zone in a relatively short time. Excavation using an LDA is evaluated for potential implementation at the Oil Landfarm. This alternative is not feasible at the C-720 Northeast and Southeast sites due to the high risk of damaging utilities present in the subsurface. Requirements and conceptual designs for each element of Alternative 4 are discussed below. A schematic view of the excavation and treatment process is provided in Figure 3.6. A plan view of the overall layout for the Oil Landfarm, including soil stockpile areas, are shown in Figure 3.7.

#### 3.4.4.1 RDSI

An RDSI would be performed at the Oil Landfarm to determine better the extent and distribution of VOCs, including DNAPL TCE, and to determine UCRS soil and groundwater parameters specific to the reagent used, as necessary, in the excavation buffer zone. Based on the calculated RGs for VOC concentrations in source area soil presented in Section 2.2, supplemental investigations to delineate the lateral and vertical extent of VOC contamination at the Oil Landfarm would be completed as described for Alternative 3.

**B**  
NORTHWEST

**B'**  
NORTHEAST

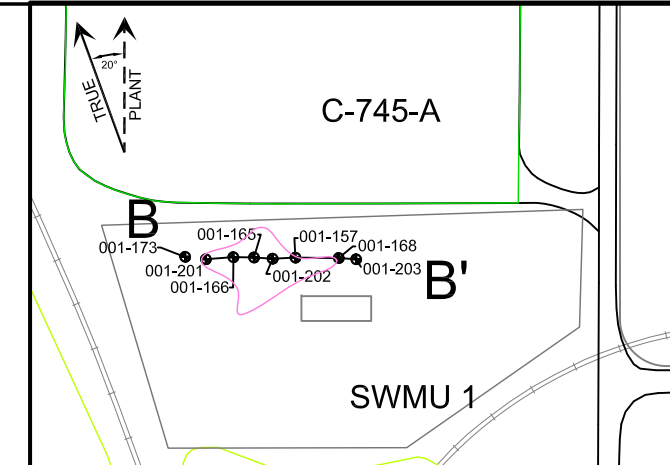
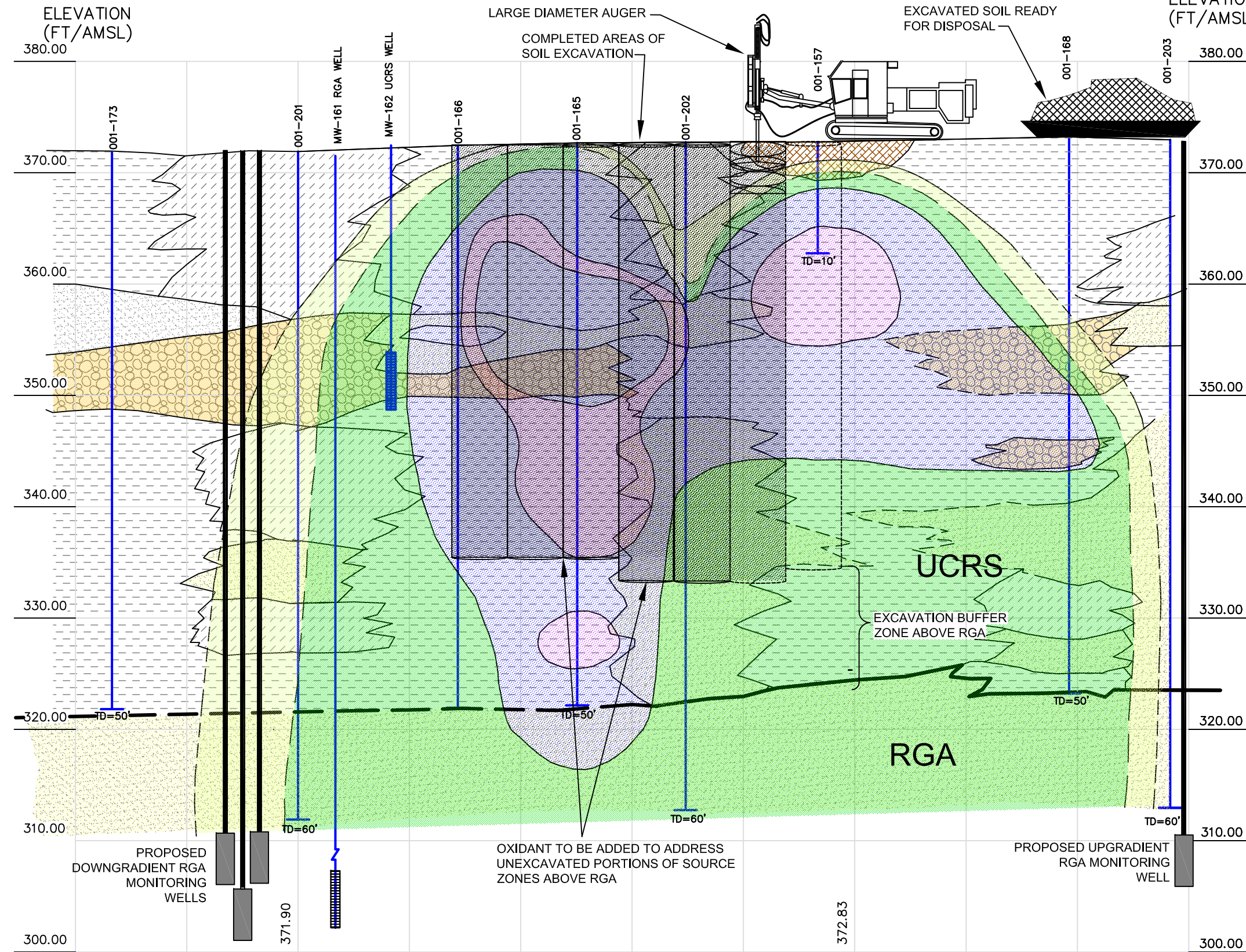

**LOCATION MAP**  
SCALE: 1" = 200'

**LEGEND**

- GRAVEL
- CLAY
- SAND
- SILT
- FILL
- PROPOSED RGA WELL SCREEN
- EXISTING RGA WELL SCREEN
- EXISTING UCRS WELL SCREEN
- DASHED WHERE INFERRED
- UCRS - UPPER CONTINENTAL RECHARGE SYSTEM
- RGA - REGIONAL GRAVEL AQUIFER
- WATER LEVEL AT TIME OF GEOPHYSICAL LOG

**TCE SOIL CONCENTRATION**

- 90 - 999 µg/kg
- 1000 - 9,999 µg/kg
- 10,000 - 49,000 µg/kg
- 50,000 - 99,999 µg/kg
- > 100,000 µg/kg symbol"/> > 100,000 µg/kg

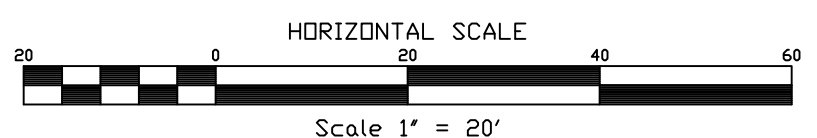
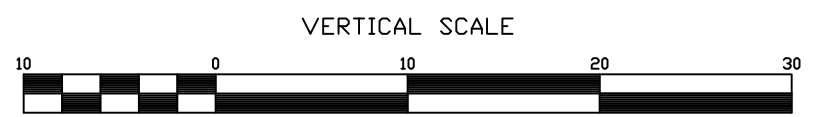

0+00      1+00  
WELLS MW-161 AND MW-162 PROJECTED ON SCHEMATICS TO SHOW APPROXIMATE GROUNDWATER LEVEL IN TREATMENT AREA.

	U.S. DEPARTMENT OF ENERGY DOE PORTSMOUTH/PADUCAH PROJECT OFFICE PADUCAH GASEOUS DIFFUSION PLANT
--	---

**Figure 3.6.**  
**Schematic View of Alternative 4 – Source Removal and *In situ* Chemical Source Treatment with Interim Land Use Controls**

FILE NAME: Fig 3-16	PROJECT #: 11105	SCALE: AS NOTED	DATE: 1/5/2011
---------------------	------------------	-----------------	----------------



**THIS PAGE INTENTIONALLY LEFT BLANK**

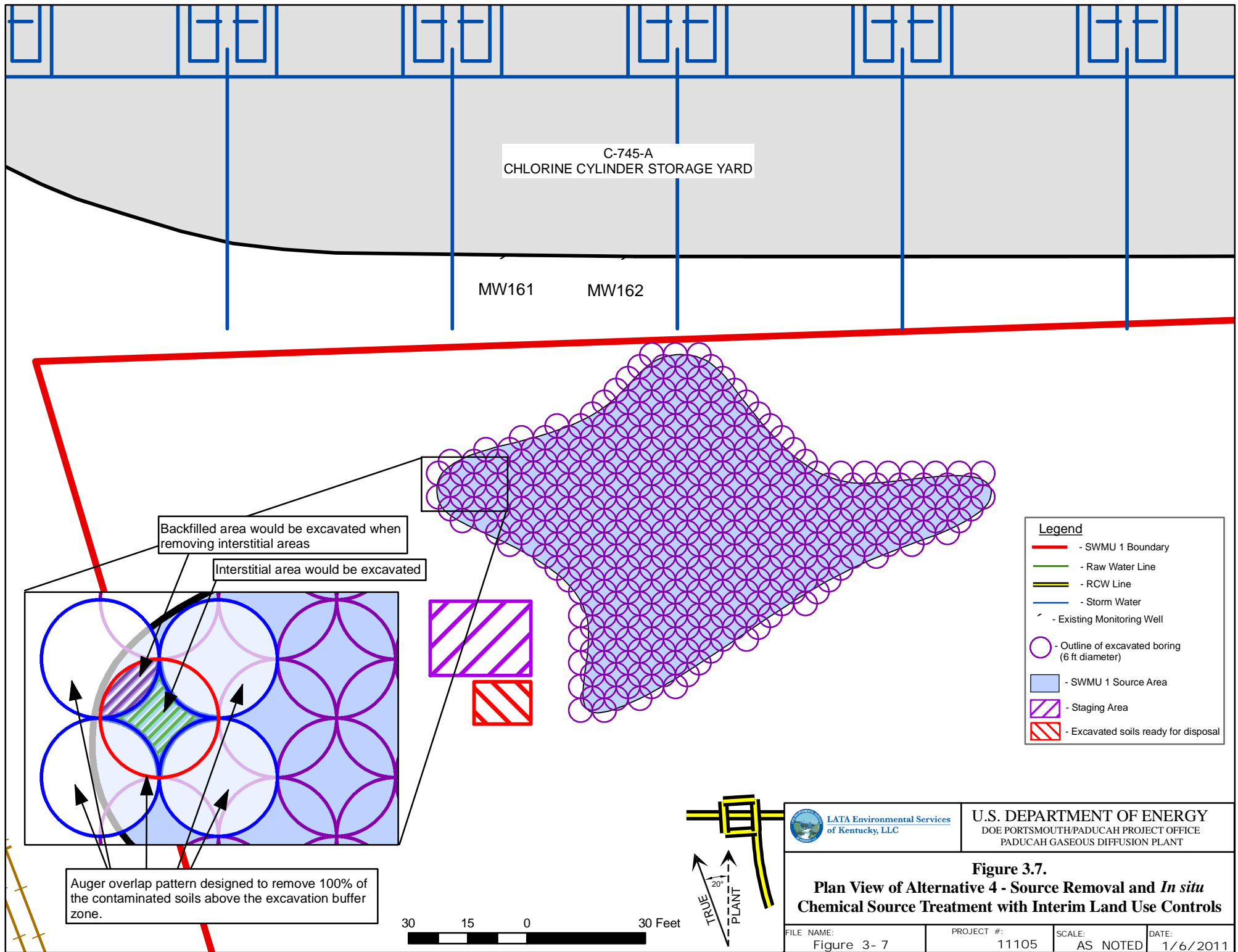

C-745-A  
CHLORINE CYLINDER STORAGE YARD

MW161

MW162

Backfilled area would be excavated when removing interstitial areas

Interstitial area would be excavated

Auger overlap pattern designed to remove 100% of the contaminated soils above the excavation buffer zone.

**Legend**

- - SWMU 1 Boundary
- - Raw Water Line
- - RCW Line
- - Storm Water
- Existing Monitoring Well
- Outline of excavated boring (6 ft diameter)
- SWMU 1 Source Area
- Staging Area
- Excavated soils ready for disposal

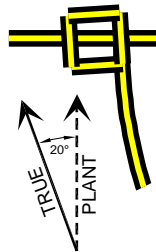

LATA Environmental Services  
of Kentucky, LLC

U.S. DEPARTMENT OF ENERGY  
DOE PORTSMOUTH/PADUCAH PROJECT OFFICE  
PADUCAH GASEOUS DIFFUSION PLANT

**Figure 3.7.**  
**Plan View of Alternative 4 - Source Removal and *In situ* Chemical Source Treatment with Interim Land Use Controls**

FILE NAME: Figure 3- 7	PROJECT #: 11105	SCALE: AS NOTED	DATE: 1/6/2011
---------------------------	---------------------	--------------------	-------------------

The extent and distribution of VOCs in the UCRS would impact the spacing/locations and depth of the excavated areas and the amount and type of reagent needed to treat contamination present in the unexcavated buffer zone. The amount and type of reagent chosen would be based on RDSI sampling results.

The RDSI would be based on a systematically planned approach developed in the RD Work Plan. The conceptual design for the RDSI includes these elements:

- Preliminary soil gas sampling using the MIP and on-site analysis for VOCs at the Oil Landfarm to estimate the areal and vertical extent of contamination, including DNAPL.
- Soil coring using DPT and analysis for VOCs using EPA SW-846 Method 8260B or equivalent at locations that have been identified using the MIP results. Soil cores also would be evaluated to determine the presence or absence of DNAPL.
- Civil survey of all sampling locations.

The primary design elements that would be taken into consideration if LDA were implemented at the Oil Landfarm include the following:

- The amount and type of reagent used to treat the excavation buffer zone (i.e., oxidant, ZVI, or bioamendment). Many options exist within each category of reagent (i.e., oxidants include chemical species such as permanganate, hydrogen peroxide, sodium persulfate, ozone, etc.).
- Locations and spacing of the borings.
- Permeability/stability of the source area following excavation and treatment.

#### **3.4.4.2 LDA Excavation**

LDA excavation would be performed using a drilling rig equipped with a large diameter (6-ft) solid-stem auger. Due to the transmissive nature of the RGA directly below the UCRS, heaving in the borehole could potentially occur. To prevent heaving, an excavation buffer zone of approximately 10 ft would be maintained between the completed borings and the top of the RGA (Figure 3.6). The spacing and locations of the borings would be designed to remove 100% of contaminated soils above the excavation buffer zone. Following excavation, an amendment would be added, as necessary, to the excavation buffer zone; confirmatory sampling would be completed; and the borehole would be filled with permeable flowable fill material to allow recharge through the source area. Recharge would allow for more percolation of amendment placed into the bottom of the completed borings to treat contamination present in the excavation buffer zone.

#### **3.4.4.3 Waste management and disposal**

Excavated soils would be stockpiled on-site within an area of contamination (AOC) consistent with to be considered (TBC) guidance and ARARs, pending disposal. Stockpiles likely would require dust emission controls, as well as storm water runoff controls. Use of tarps, foams, or other measures for air emission controls and use of storm water best management practices (BMPs) would be evaluated in the RD/RAWP. A management plan for the stockpiles, including segregation of soils as hazardous and non-hazardous, would be required in the RD/RAWP.

For costing purposes, we assumed that wastes would be managed and disposed of as 60% mixed waste and 40% nonhazardous waste, pending sampling. Mixed waste would be disposed of at an appropriate off-site disposal facility. Nonhazardous waste with PCB concentrations below 50 ppm would be disposed of at the on-site solid waste disposal facility. Actual disposal requirements would be determined by sampling of excavated soils. All waste would be managed in accordance with ARARs.

#### **3.4.4.4 Treatment**

An amendment would be added to the excavation buffer zone to address contamination present at these depths. The amendment would be placed in the bottom of the completed boring and allowed to infiltrate the lower UCRS soils over time. The permeable flowable fill material used for backfill would allow recharge to percolate through the lower UCRS soils and increase the effectiveness of the treatment. The type and amount of amendment would be based on RDSI sampling results.

#### **3.4.4.5 Confirmatory sampling**

Confirmatory sampling and analysis of treated soils in the excavation buffer zone for VOCs would be required following completion of the *in situ* treatment phase of the remedial action. Samples also may be collected from clean backfill material to confirm soil characteristics are appropriate for use during the remedial action. A confirmatory sampling plan would be prepared during RAWP development. The conceptual design for confirmatory sampling includes soil coring using DPT and analysis for VOCs using EPA SW-846 Method 8260B or equivalent. Depths and locations of cores would be determined based on the results of the RDSI.

#### **3.4.4.6 Site restoration**

Surface restoration associated with this remedial action would include the addition of topsoil and vegetation at the Oil Landfarm. The site would be graded to promote runoff and surveyed for final as-built drawings.

#### **3.4.4.7 Groundwater monitoring**

Groundwater monitoring requirements, as described for Alternative 3, would be implemented.

#### **3.4.4.8 Interim LUCs**

Interim LUCs (E/PP program and warning signs), as described for Alternative 2, would be implemented.

#### **3.4.4.9 Five-year reviews**

Five-year reviews, as described for Alternative 2, would be implemented as long as soil contaminant concentrations remained above RGs.

### **3.4.5 Alternative 5—In situ Thermal Source Treatment with Interim LUCs**

Alternative 5 consists of the following:

- RDSI
- Treatment using ERH with vapor extraction
- Treatment of recovered vapor
- Process monitoring

- Confirmatory sampling
- Secondary waste management
- Site restoration
- Groundwater monitoring
- Interim LUCs (i.e., warning signs and E/PP program)
- Five-year reviews

This alternative would reduce the VOC sources, including PTW, in the UCRS; prevent contaminant migration by reducing recharge in the UCRS, thereby mitigating the secondary release mechanism; and eliminate risks to receptors by eliminating the exposure pathways, as described in the CSM presented in Section 1. This alternative would reduce the VOC secondary source and eliminate risks to receptors by eliminating the exposure pathways. Requirements and conceptual designs for each element of Alternative 5 are discussed below in detail. The ERH system design would include measures to reduce the potential for mobilization of DNAPL TCE during treatment. Although Tc-99 is not expected to be present in groundwater during treatment, if it is encountered measures will be taken, as necessary, to ensure Tc-99 concentrations will meet ARARs, as described in Table 4.2. Five-year reviews would be required until RGs were met.

Conceptual design and a cost estimate for the ERH treatment component of Alternative 5 were provided by the McMillan-McGee Corp and were modified based on implementation of Phase I of the C-400 Interim Remedial Action. The McMillan-McGee Corp. is cited because they currently are contracted to implement ERH at the PGDP C-400 area. Other vendors and proprietary ERH technologies are available. Specific citation of the McMillan-McGee Corp., and their proprietary technology would not constrain selection of an alternative ERH technology or vendor.

The ERH treatment system design would include measures to ensure that DNAPL TCE was not mobilized during treatment. Details for each element of Alternative 5 are discussed below. A schematic view of the ERH treatment process is provided in Figure 3.8, and a plan view of the overall layout for the Oil Landfarm and the C-720 Northeast and Southeast Sites are shown in Figures 3.9 and 3.10, respectively.

### **3.4.5.1 RDSI**

A RD investigation would be performed at the Oil Landfarm and the C-720 Northeast and Southeast Sites to bound and confirm the extent of VOCs and DNAPL TCE and to close data gaps concerning the areal and vertical extent of contamination, and the mass of VOC contamination present in the UCRS. Based on the calculated RGs for VOC concentrations in source area soil presented in Section 2.2, supplemental investigations to delineate the lateral and vertical extent of VOC contamination at the source areas would be completed as described for Alternative 3. The RDSI would be based on a systematically planned approach. The conceptual design for the RDSI includes these elements:

- Preliminary soil gas sampling using the MIP and on-site analysis for VOCs at the C-720 Area Northeast and Southeast Sites to bound and confirm the areal and vertical extent of contamination including DNAPL;
- Preliminary soil gas sampling using the MIP and on-site analysis for VOCs at the Oil Landfarm to bound and confirm the vertical and areal extent of contamination including DNAPL;

**B**  
SOUTHWEST  
ELEVATION  
(FT/AMSL)

**B'**  
SOUTHEAST  
ELEVATION  
(FT/AMSL)

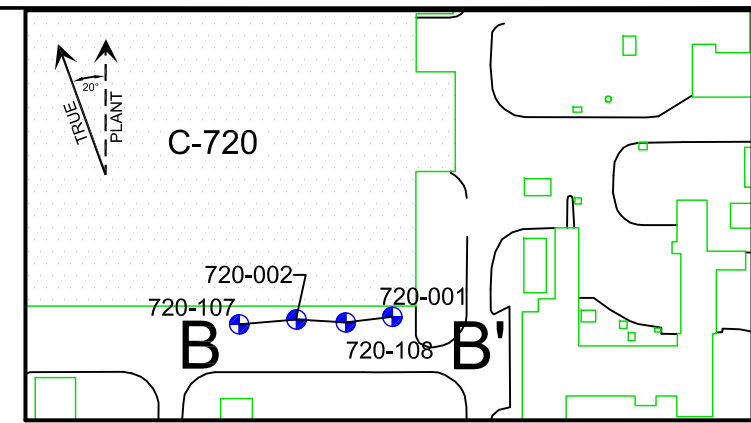

**LOCATION MAP**  
SCALE: 1" = 200'

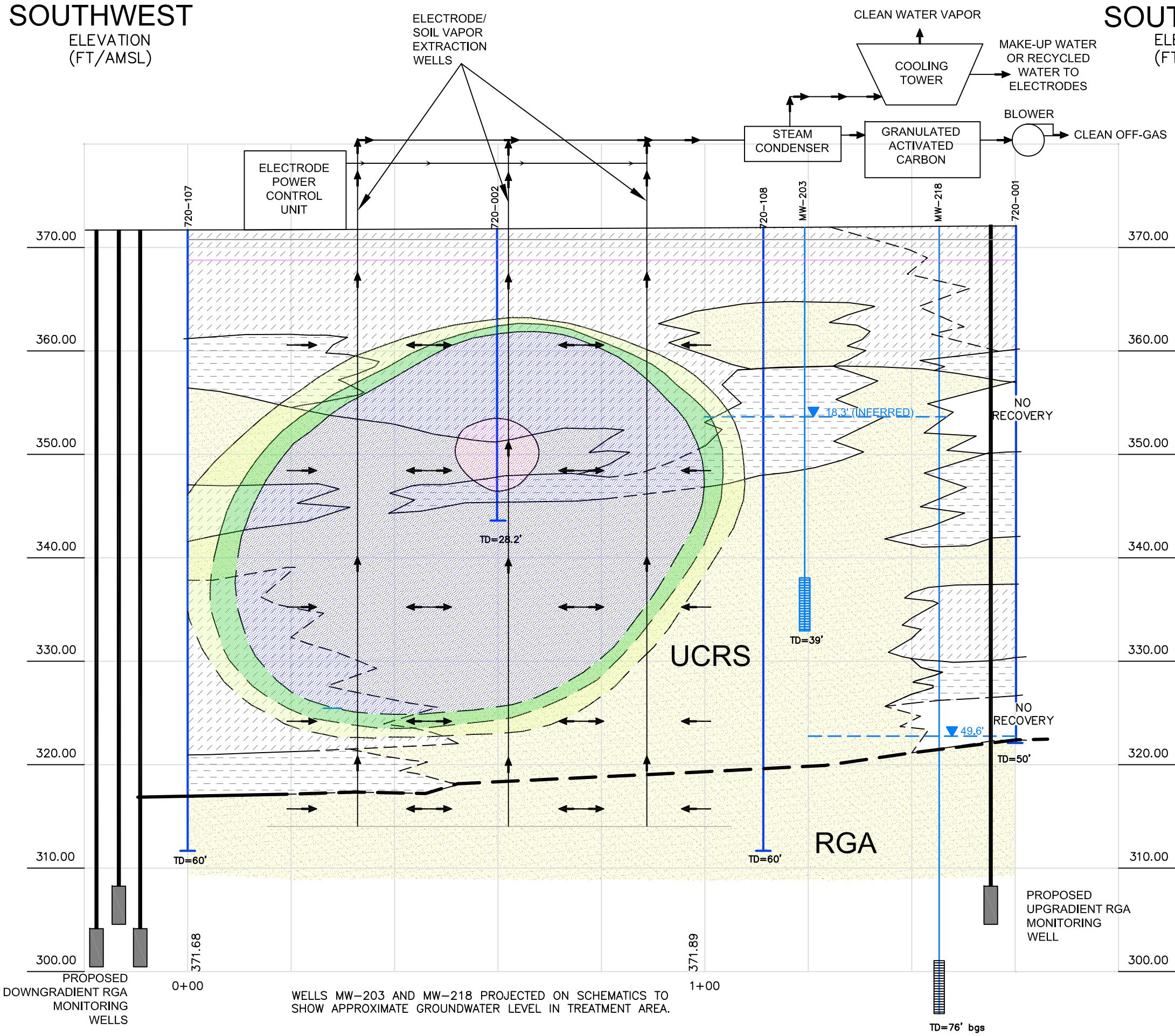

**LEGEND**

- CLAY
- SAND
- SILT
- NO RECOVERY
- WATER LEVEL AT TIME OF GEOPHYSICAL LOG
- DASHED WHERE INFERRED
- PROPOSED RGA WELL SCREEN
- EXISTING RGA WELL SCREEN
- EXISTING UCRS WELL SCREEN
- UCRS - UPPER CONTINENTAL RECHARGE SYSTEM
- RGA - REGIONAL GRAVEL AQUIFER

NOTE: NO RECOVERY, LITHOLOGY INFERRED BASED ON DRILLING METHOD OR BORING RECORD NOTES.

**TCE SOIL CONCENTRATION**

- 90 - 999 µg/kg
- 1000 - 9,999 µg/kg
- 10,000 - 49,000 µg/kg
- 50,000 - 99,999 µg/kg
- > 100,000 µg/kg symbol"/> > 100,000 µg/kg

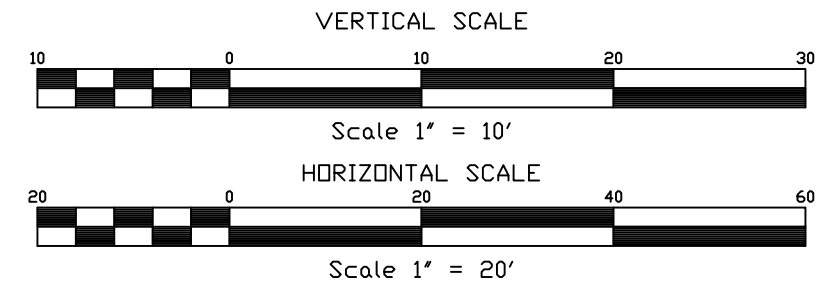

U.S. DEPARTMENT OF ENERGY  
DOE PORTSMOUTH/PADUCAH PROJECT OFFICE  
PADUCAH GASEOUS DIFFUSION PLANT

**Figure 3.8.**  
**Schematic View of Alternative 5 – In situ Thermal Source Treatment with Interim Land Use Controls**

FILE NAME: Fig 3-8	PROJECT #: 11105	SCALE: AS NOTED	DATE: 1/5/2011
-----------------------	---------------------	--------------------	-------------------

**THIS PAGE INTENTIONALLY LEFT BLANK**

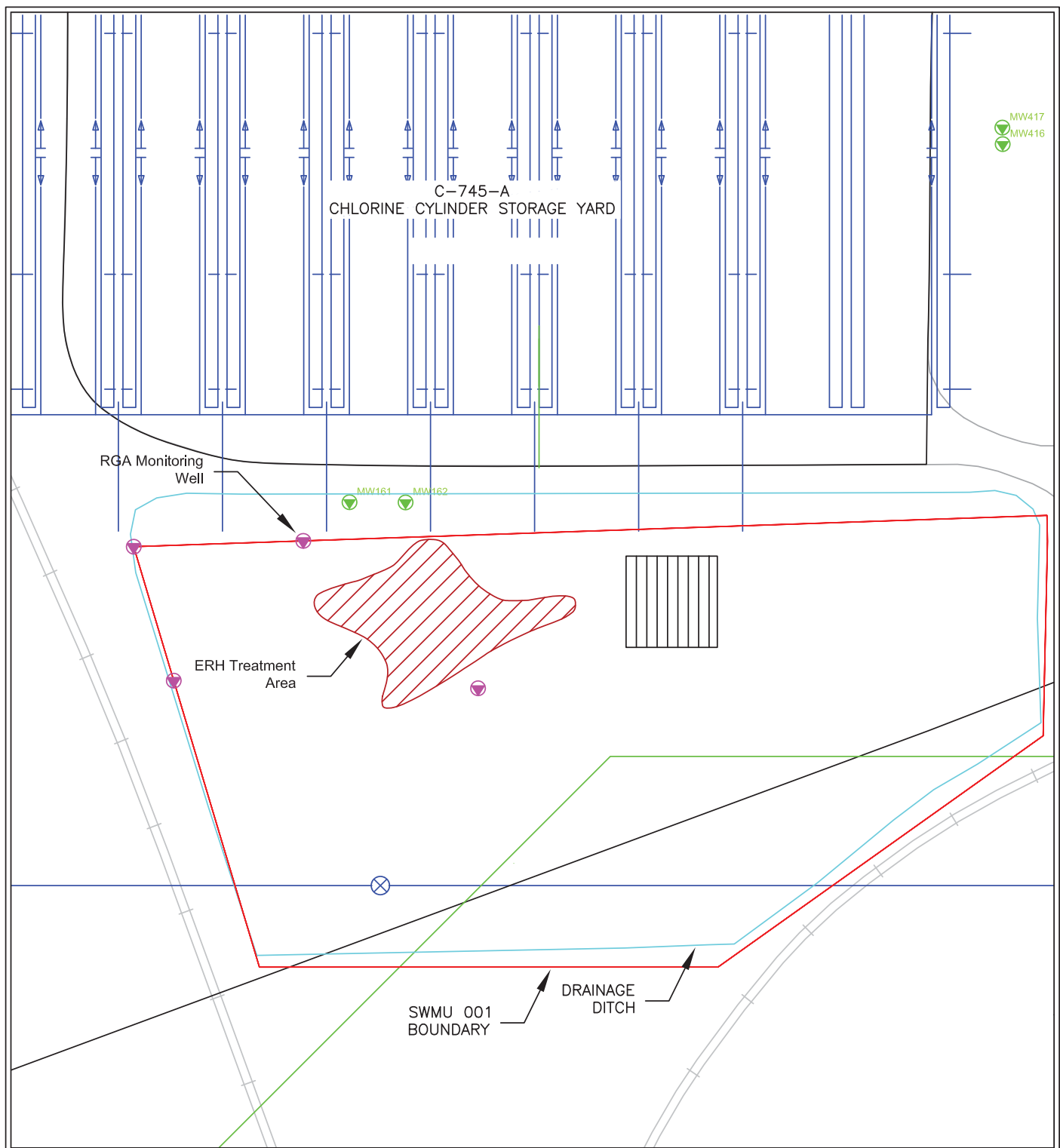

**Legend**

- Source Area
- Treatment System Area
- Sanitary Water Line
- Drainage Ditch
- RCW Line
- SWMU Boundary
- Storm Drains
- Existing Monitoring Well
- Proposed Monitoring Well

**Notes**

Source Area: 5810 ft<sup>2</sup> (540 m<sup>2</sup>)

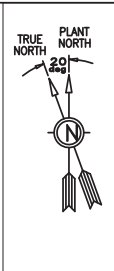

U.S. DEPARTMENT OF ENERGY  
DOE PORTSMOUTH/PADUCAH PROJECT OFFICE  
PADUCAH GASEOUS DIFFUSION PLANT

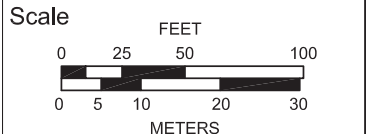
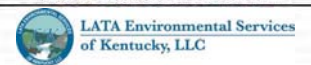

**Figure 3.9. Plan View of Alternative 5 at the Oil Landfarm**



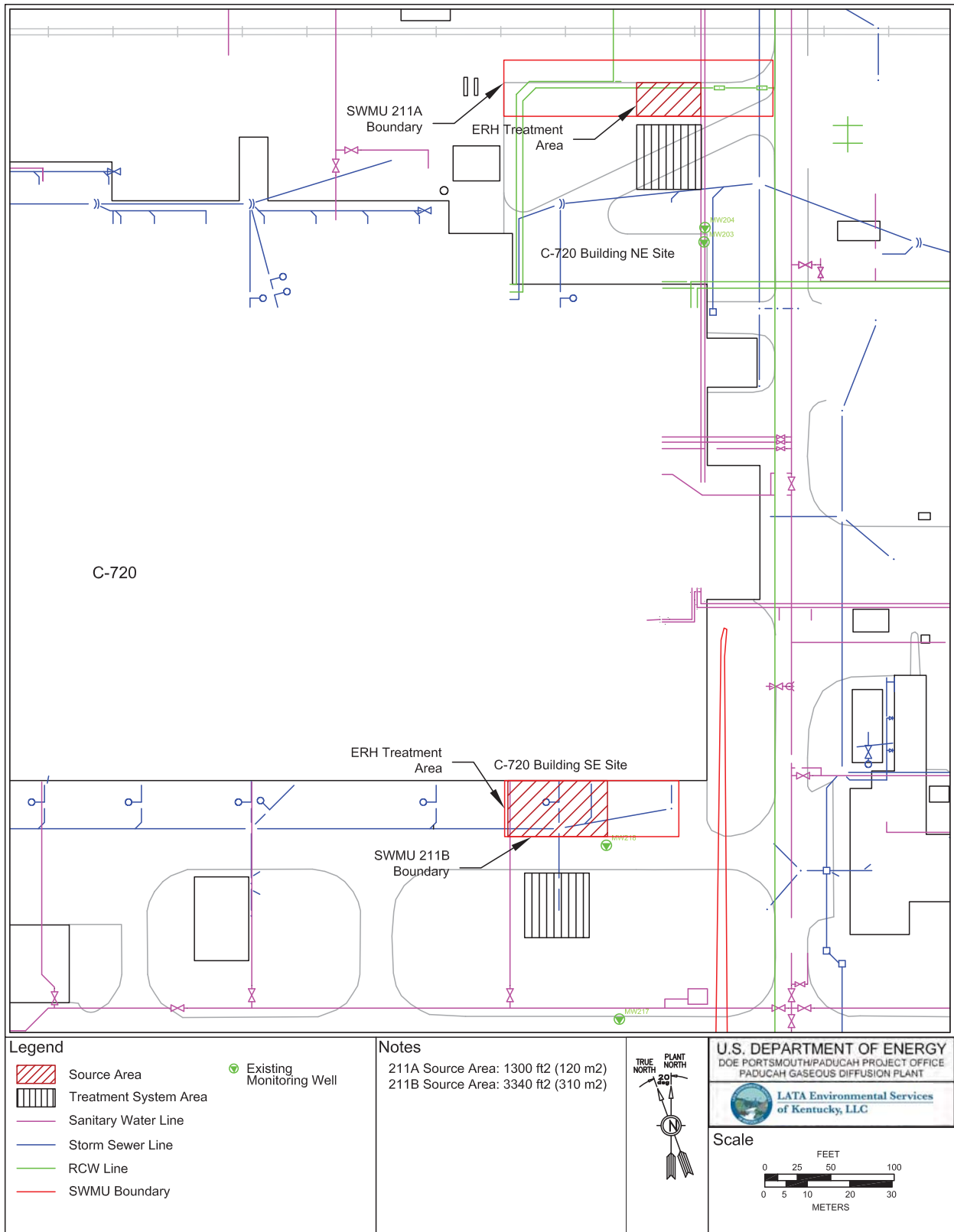

Figure 3.10. Plan View of Alternative 5 at C-720 Northeast and Southeast Sites

- Soil coring using DPT and analysis for VOCs using EPA SW-846 Method 8260B or equivalent at locations that have been identified using the MIP results. Soil cores also would be evaluated to determine the presence or absence of DNAPL; and
- Civil survey of all sampling locations.

### **3.4.5.2 Treatment**

McMillan-McGee Corp. implements a proprietary ERH approach trademarked as the Electro Thermal Dynamic Stripping Process (ET-DSP™). Using this approach, electrodes are strategically placed into the contaminated zone in a pattern such that conventional three-phase power can be used to heat the soil. The distance between electrodes and their location is determined from the heat transfer mechanisms associated with vapor extraction, electrical heating, and fluid movement in the contaminated zone. To determine the ideal pattern of electrode and extraction wells, a multiphase, multi-component, 3-D thermal model is used to simulate the process. Numerical modeling is also used to design the power delivery system, the power requirements from the utility, and the project capital requirements (McMillan-McGee 2009).

Overall the ERH treatment system conceptual design for the three Southwest Plume source areas includes the following:

- 272 total electrodes
- 68 electrode wells
- 24 UCRS wells
- 8 contingency wells
- 6 digital thermocouple temperature MWs
- 18 vacuum monitoring/digital thermocouple temperature MWs
- Well field piping
- Recovery of TCE from vapor using GAC and off-site regeneration

Phase I of the C-400 Interim Remedial Action that was performed in the UCRS identified that monitoring items, including the vacuum extraction wells, required closer spacing. Design elements are currently underway for the Phase II operations, and it is expected that areal spacing for the vacuum extraction wells will be reduced from approximately 190 ft<sup>2</sup> to 98 ft<sup>2</sup>. The electrode spacing in both the vertical and horizontal distances was found to be sufficient in the UCRS and were not adjusted from the original design.

In addition to characterization of the site for contaminant concentration levels, as described above, electrical conductivity of the soil and its distribution would be measured. During Phase I of the C-400 Interim Remedial Action, these parameters were found to be sensitive to the creation of electrical resistance in the soil, which generates the desired heating. This involves measurements of the electrical properties of the soil as a function of temperature and water saturation. These data are used to design the power delivery system, estimate the time required to heat the soil, determine power requirements and electrical characteristics such as voltages, and numerically simulate the heating process. All existing polyvinyl chloride (PVC) wells within the source areas would be abandoned due to heat effects to the PVC pipe. A variance to 401 KAR 6:350 § 11 to abandon existing PVC wells in place prior to starting thermal treatment would be approved through the CERCLA document review process.

The electrodes are arranged so that the contaminated volume of soil is contained inside the periphery of the electrodes. The vapor extraction wells are located within the contaminated soil. The position of the extraction wells relative to the electrodes is determined so that heat transfer by convection within the

porous soil is maximized, thus minimizing heat losses and increasing the uniformity of the temperature distribution.

A conventional water handling and vapor recovery system is installed as part of the process. The water circulation system provides water to the electrode wells to prevent overheating. The electrode wells are designed with fluid injection capability; therefore, some of the injected water flows from the electrode wells towards the vapor extraction wells. The heat transported by fluid movement tends to heat the soil rapidly and uniformly and is an integral stage of ET-DSP™. The produced fluids increase with temperature over time. These fluids are reinjected and the overall thermal efficiency is improved. The electrical current path is shared between the electrodes passing through the connate water in the porous soil. The temperature is controlled to minimize drying out of the soil until the latter stages of the heating process.

As the soil changes in temperature, the resistivity of the connate water typically will decrease. Also, as the soil dries out, the resistivity will increase. A computer control system is installed to ensure that the maximum current is applied to the subsurface via the electrodes at all times. The electrodes are connected to a three-phase power delivery system. The power delivery system is equipped with computer controls so that the power from the three phases can be alternated among the electrodes.

McMillan-McGee Corp. utilizes a system of Time-Distributed Control and Inter-Phase Synchronization to control the power to the electrodes. This process effectively controls the amount and timing of power sent to individual electrodes. For example, should it become apparent that certain electrodes are in electrically resistive zones resulting in cold spots, the power to the electrodes can be increased in these areas to ensure uniform heating. Using readily available three-phase power eliminates the need for expensive specialty transformers and higher capital costs. This system is fully programmable and can be accessed over the Internet for remote monitoring and control.

PCBs, other SVOCs, metals, and radionuclides potentially present at the Oil Landfarm would be expected to remain in the soils and would not be removed in the recovered vapor.

The installation and treatment period is estimated at approximately one year. System shutdown criteria would be established in the RD and would incorporate additional lessons learned from Phase II of the C-400 Interim Remedial Action.

#### **3.4.5.3 Process monitoring**

TCE vapor waste stream concentrations would be measured daily at the influent of the primary GAC vessel using a photo acoustic analyzer. The vapor waste stream velocity also would be measured daily using a handheld flow meter. The resulting measurements would be used to calculate the approximate TCE loading and mass removal rate for each GAC vessel.

Air samples would be collected weekly from the influent of the primary GAC using summa canisters. The summa canisters would be configured to collect a 24-hour integrated sample. The air samples would be sent off-site for laboratory analysis using analytical method TO-14A.

Subsurface temperatures and electrical usage would be monitored by the vendor.

#### **3.4.5.4 Confirmatory sampling**

Confirmatory sampling in the treatment area would be required to determine posttreatment TCE soil concentrations. A confirmatory sampling plan would be prepared during RAWP development. The

conceptual design for confirmatory sampling includes soil coring using DPT and analysis for VOCs using EPA SW-846 Method 8260B or equivalent. Depths and locations of cores would be determined based on the results of the RDSI.

#### **3.4.5.5 Secondary waste management**

Secondary wastes would include vapor, spent GAC, drill cuttings (produced during installation of electrodes and vapor recovery wells), PPE, and decontamination fluids. TCE would be recovered from vapor phase on GAC and shipped for off-site regeneration or disposal, depending on GAC characterization results. Water condensate would be recirculated to the electrode wells to reduce drying of the soil, as necessary, to maintain soil resistance.

For cost-estimating purposes, drill cuttings, PPE, and decontamination fluids were assumed to require containerization, dewatering, and testing prior to off-site disposal. Actual dispositioning requirements would be determined by sampling of containerized soils. All secondary wastes would be managed in accordance with all ARARs.

It is reasonably expected that the Southwest Plume project effluent will meet all ambient water quality criteria (AWQC) in the receiving stream if the concentration of TCE and the specified degradation products are at or below the Kentucky numeric water quality criteria for fish consumption specified in Table I of 401 *KAR* 10:031 Section 6(1). There are no waste load allocations approved by EPA pursuant to 40 *CFR* § 130.7 for the receiving stream (Bayou Creek) that would impact effluent limits based on the numeric water quality criteria for fish consumption specified in Table I of 401 *KAR* 10:031 Section 6(1).

#### **3.4.5.6 Site restoration**

Site restoration activities would include demobilizing and removing all RDSI equipment; sealing all MIP and soil coring locations with bentonite; reseeding disturbed vegetated areas at the Oil Landfarm and the C-720 Northeast Site; and repairing penetrations of asphalt and concrete at the C-720 Northeast and Southeast Sites. ERH equipment would be removed from vapor recovery wells to the extent feasible and the electrode and vacuum extraction wells abandoned in place. If wetlands are identified, actions will be taken, as necessary, in accordance with the identified ARARs.

#### **3.4.5.7 Groundwater monitoring**

Groundwater monitoring would be used to determine the effectiveness of the remedy and the rate of contaminant migration from the UCRS to the RGA. One upgradient and three downgradient wells screened in the shallow RGA would be constructed at each source area. Wells would be monitored at a frequency to be determined for VOCs, pH, conductivity, and water levels, and potentially other analytes, as needed. All constituents sampled would be included in the RAWP. Results would be reported as part of the five-year reviews and provided to the sitewide environmental monitoring program and to the Dissolved-Phase Plumes Remedial Action Project under the Groundwater OU. MWs would remain in place until soil RGs were attained.

#### **3.4.5.8 Interim LUCs**

Interim LUCs, including the E/PP program and warning signs, as described for Alternative 2, would be implemented.

### 3.4.5.9 Five-year reviews

Five-year reviews, as described for Alternative 2, would be implemented as long as soil contaminant concentrations remained above RGs.

### 3.4.6 Alternative 6—In situ Source Treatment Using LAI with Interim LUCs

Alternative 6 consists of the following:

- RDSI
- Injection of a reagent (i.e., oxidant, ZVI, or bioamendment) into the UCRS source areas using LAI
- Secondary waste management
- Confirmatory sampling
- Site restoration
- Groundwater monitoring
- Interim LUCs (i.e., warning signs and E/PP program)
- Five-year reviews

This alternative would reduce the mass of VOCs present in the source areas and eliminate risks to receptors by eventually eliminating the exposure pathways shown in Figure 1.19. LAI is evaluated for potential implementation at the C-720 Northeast and Southeast Sites, where utilities in the subsurface make deep soil mixing an impractical delivery mechanism for emplacing reagents in the subsurface. This alternative is not developed further for the Oil Landfarm because the relative cost of jet injection is similar to deep soil mixing, but the effectiveness is not as certain. Requirements and conceptual designs for each element of Alternative 6 are discussed here in detail. A schematic view of the LAI treatment process is provided in Figure 3.11, and a plan view of the overall layout for the C-720 Northeast and Southeast Sites are shown in Figures 3.12 and 3.13, respectively.

#### 3.4.6.1 RDSI

An RDSI would be performed at the C-720 Northeast and Southeast Sites to delineate better the extent of VOCs and DNAPL TCE and to close any data gaps concerning the areal and vertical extent of contamination. Based on the calculated RGs for VOC concentrations in source area soil presented in Section 2.2, supplemental investigations to delineate the lateral and vertical extent of VOC contamination at the source areas would be completed as described for Alternative 3. The RDSI would be based on a systematically planned approach. The conceptual design for the RDSI includes these elements:

- Preliminary soil gas sampling using the MIP and on-site analysis for VOCs at the C-720 Area Northeast and Southeast Sites to estimate the areal and vertical extent of contamination including DNAPL;
- Soil coring using DPT and analysis for VOCs using EPA SW-846 Method 8260B or equivalent at locations that have been identified using the MIP results. Soil cores also would be evaluated to determine the presence or absence of DNAPL;
- Field-scale testing to determine typical propagation distances in the subsurface and the appropriate reagent mixture to be added during the LAI process; and
- Civil survey of all sampling locations.

**B**  
SOUTHWEST  
ELEVATION  
(FT/AMSL)

**B'**  
SOUTHEAST  
ELEVATION  
(FT/AMSL)

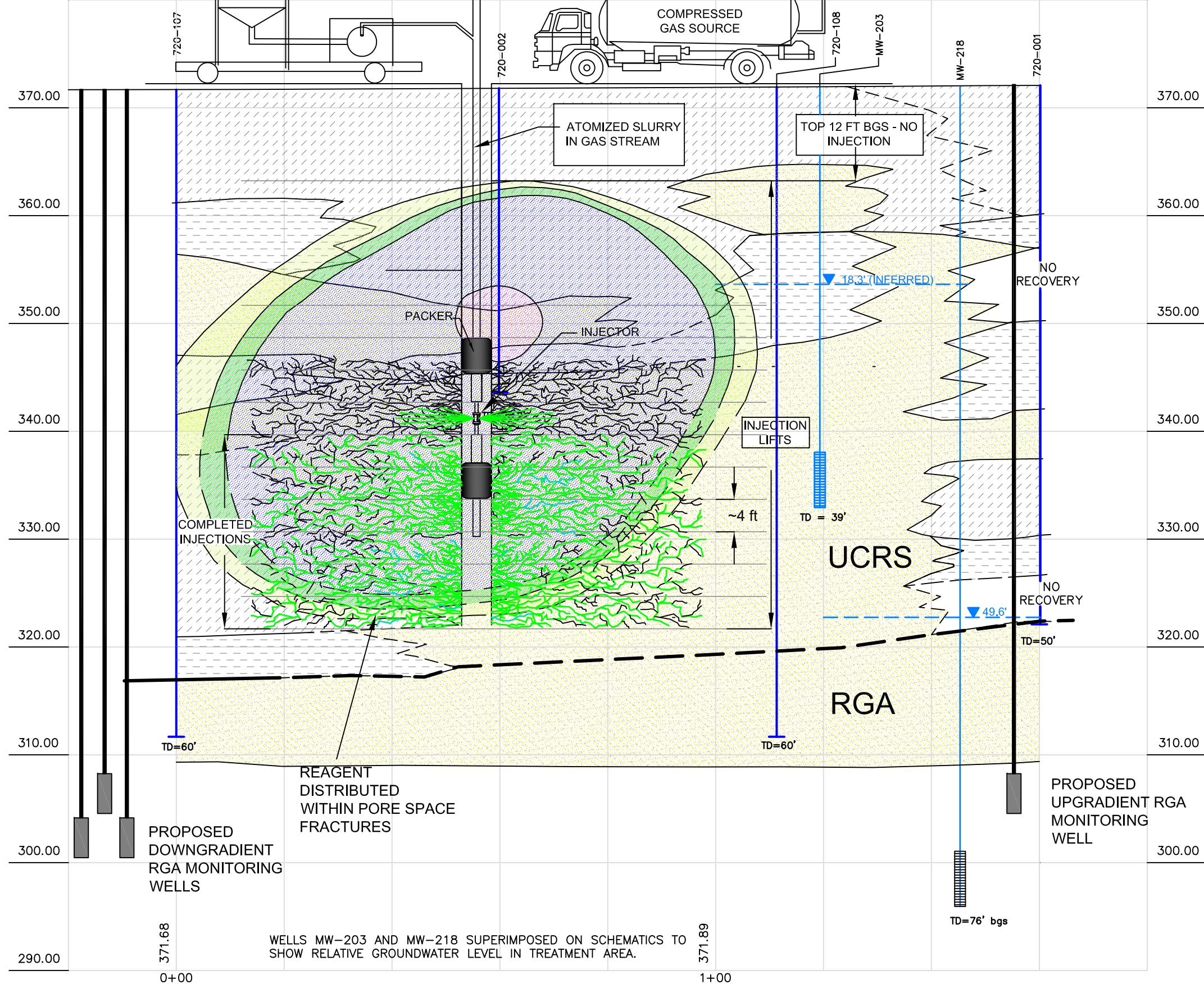

WELLS MW-203 AND MW-218 SUPERIMPOSED ON SCHEMATICS TO SHOW RELATIVE GROUNDWATER LEVEL IN TREATMENT AREA.

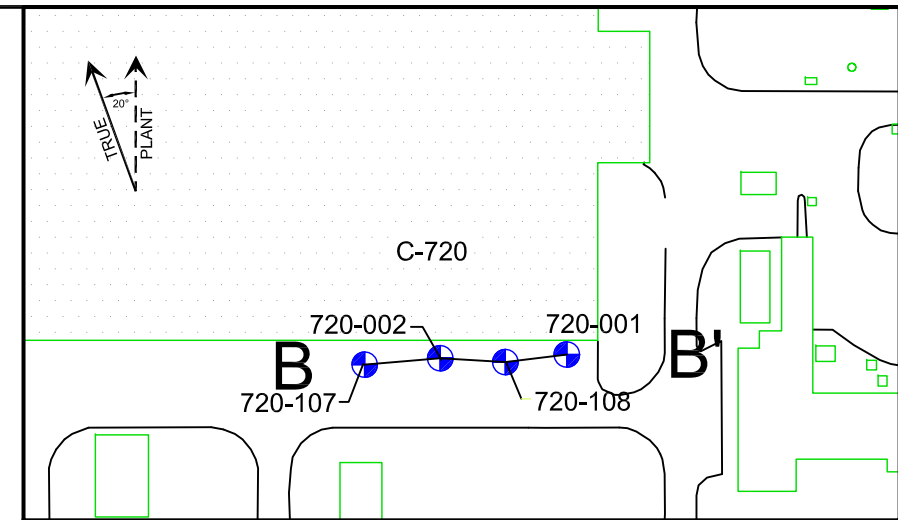

**LOCATION MAP**  
SCALE: 1" = 150'

**LEGEND**

- CLAY
- SAND
- SILT
- NO RECOVERY
- DASHED WHERE INFERRED
- PROPOSED RGA WELL SCREEN
- EXISTING RGA WELL SCREEN
- EXISTING UCRS WELL SCREEN
- WATER LEVEL AT TIME OF GEOPHYSICAL LOG
- UCRS - UPPER CONTINENTAL RECHARGE SYSTEM
- RGA - REGIONAL GRAVEL AQUIFER

NOTE: NO RECOVERY, LITHOLOGY INFERRED BASED ON DRILLING METHOD OR BORING RECORD NOTES.

**TCE SOIL CONCENTRATION**

- 90 - 999 µg/kg
- 1000 - 9,999 µg/kg
- 10,000 - 49,000 µg/kg
- 50,000 - 99,999 µg/kg
- > 100,000 µg/kg color swatch"/> > 100,000 µg/kg

**VERTICAL SCALE**

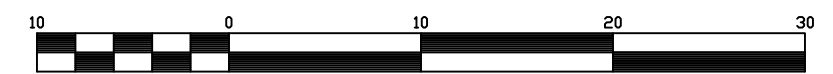

Scale 1" = 10'

**HORIZONTAL SCALE**

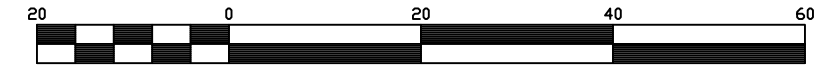

Scale 1" = 20'

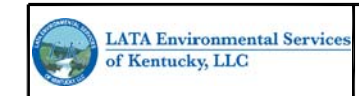

U.S. DEPARTMENT OF ENERGY  
DOE PORTSMOUTH/PADUCAH PROJECT OFFICE  
PADUCAH GASEOUS DIFFUSION PLANT

**Figure 3.11.**  
**Schematic View of Alternative 6 – In situ Source Treatment Using Liquid Atomized Injection with Interim Land Use Controls**

FILE NAME: Fig-3-11	PROJECT #: 11105	SCALE: AS NOTED	DATE: 1/5/2011
---------------------	------------------	-----------------	----------------

**THIS PAGE INTENTIONALLY LEFT BLANK**

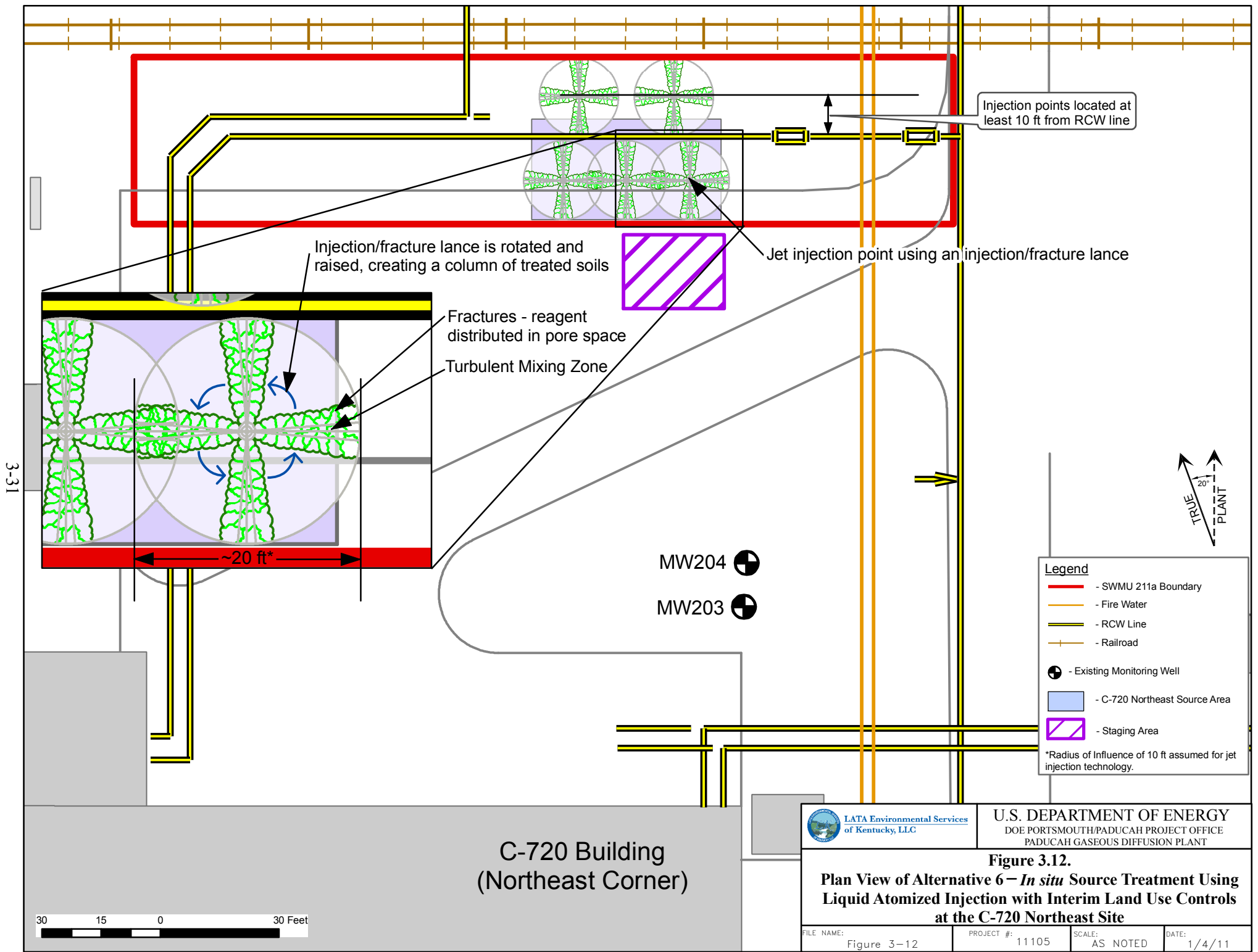

3-31

Injection points located at least 10 ft from RCW line

Injection/fracture lance is rotated and raised, creating a column of treated soils

Jet injection point using an injection/fracture lance

Fractures - reagent distributed in pore space  
Turbulent Mixing Zone

~20 ft\*

MW204  
MW203

**Legend**

- SWMU 211a Boundary
- Fire Water
- RCW Line
- Railroad
- Existing Monitoring Well
- C-720 Northeast Source Area
- Staging Area

\*Radius of Influence of 10 ft assumed for jet injection technology.

C-720 Building  
(Northeast Corner)

30 15 0 30 Feet

LATA Environmental Services  
of Kentucky, LLC

U.S. DEPARTMENT OF ENERGY  
DOE PORTSMOUTH/PADUCAH PROJECT OFFICE  
PADUCAH GASEOUS DIFFUSION PLANT

**Figure 3.12.**  
**Plan View of Alternative 6 – In situ Source Treatment Using Liquid Atomized Injection with Interim Land Use Controls at the C-720 Northeast Site**

FILE NAME: Figure 3-12	PROJECT #: 11105	SCALE: AS NOTED	DATE: 1/4/11
---------------------------	---------------------	--------------------	-----------------



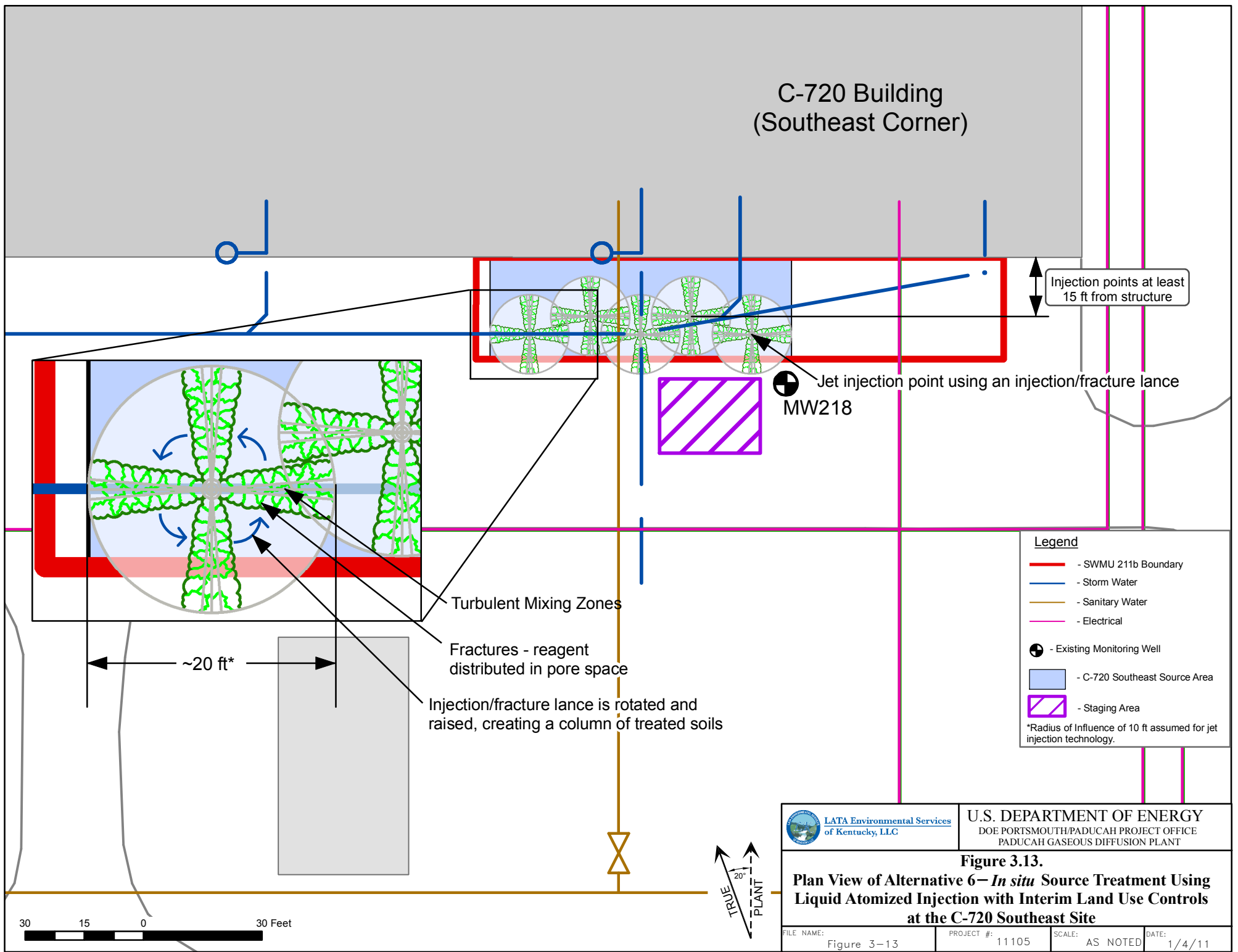

C-720 Building  
(Southeast Corner)

Injection points at least  
15 ft from structure

Jet injection point using an injection/fracture lance  
MW218

Turbulent Mixing Zones

Fractures - reagent  
distributed in pore space

Injection/fracture lance is rotated and  
raised, creating a column of treated soils

~20 ft\*

**Legend**

- SWMU 211b Boundary
- Storm Water
- Sanitary Water
- Electrical
- Existing Monitoring Well
- C-720 Southeast Source Area
- Staging Area

\*Radius of Influence of 10 ft assumed for jet injection technology.

<p>LATA Environmental Services of Kentucky, LLC</p>	<p>U.S. DEPARTMENT OF ENERGY DOE PORTSMOUTH/PADUCAH PROJECT OFFICE PADUCAH GASEOUS DIFFUSION PLANT</p>		
	<p><b>Figure 3.13.</b> <b>Plan View of Alternative 6 – <i>In situ</i> Source Treatment Using Liquid Atomized Injection with Interim Land Use Controls at the C-720 Southeast Site</b></p>		
FILE NAME:	PROJECT #:	SCALE:	DATE:
Figure 3-13	11105	AS NOTED	1/4/11

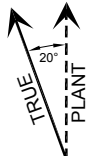
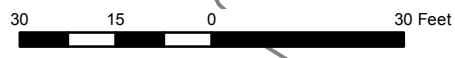

3-32

The primary design elements that would be taken into consideration if LAI were implemented at the C-720 Northeast or Southeast Sites include the following:

- Type of reagent injected (i.e., oxidant, ZVI, or bioamendment). Many options exist within each category of reagent (i.e., oxidants include chemical species such as permanganate, hydrogen peroxide, sodium persulfate, ozone, etc.).
- Dosage of reagent necessary for treatment.
- Radius of influence and the associated location and number of injection points.

#### **3.4.6.2 Injection of a reagent using LAI**

The treatment phase of this remedial alternative would consist of a high pressure injection of an aerosolized reagent. ARS Technologies, Inc., implements the proprietary LAI technology approach. LAI would be implemented using a direct-push rig to create a temporary 4-inch borehole. A reagent would be mixed on the surface and introduced into a high-flow, high-velocity gas stream (non-flammable) at the well head. No polymers, guar, or other suspension fluids are required. The LAI equipment would allow the amendment to be uniformly mixed within potable water and fed into a high velocity nitrogen gas stream, which would be directed down-hole and radially outward from the injection location. For cost estimating purposes, a radius of influence of approximately 10 ft was estimated. Using an integrated direct push injection method, a casing would be advanced to the bottom of the injection zone (approximately 50 to 60 ft bgs) to prevent borehole collapse and to facilitate deployment of the down-hole injection assembly. Once the casing was in place, the injection tooling would be lowered into the casing, which then would release the disposable casing drive point. The casing would be retracted upward to expose the injection assembly to the formation. Reagent injections would take place after isolation packers are inflated to the appropriate pressure. Depending upon the specific characteristics of the soils surrounding the injection locations, either a single, double, or triple packer system may be used. The injection configuration could be adjusted in the field, as needed. The injection would be initiated by the introduction of pressurized gas for 10 to 15 seconds either to fluidize or fracture the formation and to establish flow. The reagent slurry then would be pumped into the pressurized nitrogen gas stream at the well-head and become atomized prior to dispersion into the formation. Once the injection was complete at that interval, the packers would be deflated and the outer casing and injection assembly would be retracted upward (approximately 3.5 to 4 ft) to the next injection interval. This process would be repeated until the entire treatment zone was addressed at that location.

The injection technique could be altered by using different nozzle configurations, gas pressures, and flow rates; however, the primary driver for reagent emplacement mechanics would be the physical and mechanical soil characteristics of the sediment being treated. Prior field experience suggests three potential emplacement mechanisms in which the reagent material would be dispersed within the subsurface. These mechanisms include dispersion, fluidization, and/or fracture emplacement filling (Figure 3.11). In zones where coarse-grained materials such as sands and gravel are present, the injection of reagent powder results in dispersion around sand and gravel particles, and travels as far as the velocity of the gas carrying the particle maintains enough energy to keep it from settling. In fine to medium sands, silts and small amounts of clay, the injection of gas and slurry will result in local fluidization of the formation causing reagent particles to “mix” within the soil matrix. In very fine-grained materials such as tight clay zones, the injections will result in effective propagation of fractures within the material and filling of the fractures with reagent powder. The emplacement of reagent would be governed by the flow of gas in the fractures, and the particles would settle as the kinetic energy decreased. Depending upon the heterogeneous nature with depth of the soil in which the injection is taking place, a combination of all three emplacement mechanisms would be likely to occur.

The following alternative assumptions were made for cost estimating purposes:

- Five injection points with a radius of influence of approximately 10 ft at each of the C-720 Sites.
- Fine ZVI particles sourced from Hepure Technologies Inc., or equivalent. The HCA 200 High Purity Cast Iron product (Fe 92 % to 98 %) is particularly suited for injection due to its small particle size of less than 100 micron, high iron content (minimal oxide layer) and abundance of surface catalytic sites for improved reactivity.
- Vertical injection intervals of 4 ft.
- Injection points would be positioned at least 15 ft from load-bearing columns, walls or structures.
- Storm sewer and sanitary water lines present at the C-720 Southeast Site would be re-routed, as necessary, such that no underground utility lines would be present horizontally within 10 ft of the injection points.
- Injection points at the C-720 Northeast Site would be positioned at least 10 ft horizontally from the recirculating cooling water line.

#### **3.4.6.3 Secondary waste management**

Secondary waste could potentially be generated if reagent were to daylight to the surface through vertical fractures created during the LAI process. Approximately 1-2 drums of waste could be expected for a project the size of the C-720 Northeast and Southeast Sites. Wastes would be sampled and disposed of at an appropriate on-site or off-site disposal facility. All secondary wastes would be managed in accordance with all ARARs.

#### **3.4.6.4 Confirmatory sampling**

Confirmatory sampling in the treatment area would be required to determine posttreatment TCE soil concentrations. A confirmatory sampling plan would be prepared during RAWP development. The conceptual design for confirmatory sampling includes soil coring using DPT and analysis for VOCs using EPA SW-846 Method 8260B or equivalent. Depths and locations of cores would be determined based on the results of the RDSI.

#### **3.4.6.5 Site restoration**

Site restoration activities prior to remedy completion would include demobilizing and removing all RDSI equipment, sealing all MIP, soil coring, and DPT boreholes locations with bentonite, reseeding disturbed vegetated areas at the C-720 Northeast Site, and repairing penetrations of asphalt and concrete at the C-720 Northeast and Southeast sites. If wetlands are identified, actions would be taken in accordance with the identified ARARs.

#### **3.4.6.6 Groundwater monitoring**

Groundwater monitoring requirements, as described for Alternative 3, would be implemented.

### **3.4.6.7 Interim LUCs**

Interim LUCs, including the E/PP program and warning signs, as described for Alternative 2, would be implemented.

### **3.4.6.8 Five-year reviews**

Five-year reviews, as described for Alternative 2 would be implemented as long as soil contaminant concentrations remained above RGs.

## **3.4.7 Alternative 7—*In situ* Soil Flushing and Source Treatment Using Multiphase Extraction with Interim LUCs**

Alternative 7 consists of the following:

- RDSI
- Surfactant-enhanced soil flushing
- Multiphase extraction
- Off-gas treatment
- Co-produced groundwater treatment
- Sampling and monitoring
- O&M
- Confirmatory sampling
- Secondary waste management
- Site restoration
- Interim LUCs
- Five-year reviews

Alternative 7 combines process options from the GRAs of treatment (*in situ* and *ex situ*) and disposal. This alternative would reduce the VOC sources, including PTW, in the UCRS, and eliminate risks to receptors by eventually eliminating the exposure pathways, as described in the CSM presented in Section 1. Multiphase extraction is evaluated for potential implementation at the C-720 Northeast and Southeast Sites. This alternative is not as feasible at the Oil Landfarm due to the lower permeability of the matrix. Warning signs and boundary markers would be maintained as long as soil concentrations remained above RGs. Requirements and conceptual designs for each element of Alternative 7 are discussed below in detail.

The primary objective of combining surfactant-enhanced soil flushing and multiphase extraction is to remove the maximum amount of contamination with a minimum amount of chemicals and in minimal time, while maintaining hydraulic controls over the injected chemicals and contaminant. A schematic view of the soil flushing and multiphase extraction process is provided in Figure 3.14, and a plan view of the overall layout at the C-720 Northeast and Southeast Sites is shown in Figure 3.15 and 3.16, respectively.

### **3.4.7.1 RDSI**

An RDSI would be performed at the C-720 Northeast and Southeast Sites to better delineate the extent of VOCs and DNAPL TCE and to close any data gaps concerning the areal and vertical extent of contamination. Based on the calculated RGs for VOC concentrations in source area soil presented in

**THIS PAGE INTENTIONALLY LEFT BLANK**

**B**  
SOUTHWEST

**B'**  
SOUTHEAST

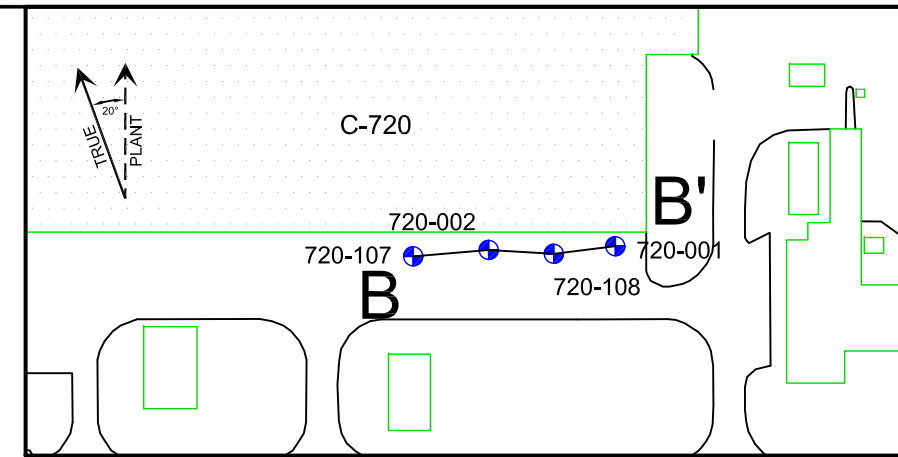
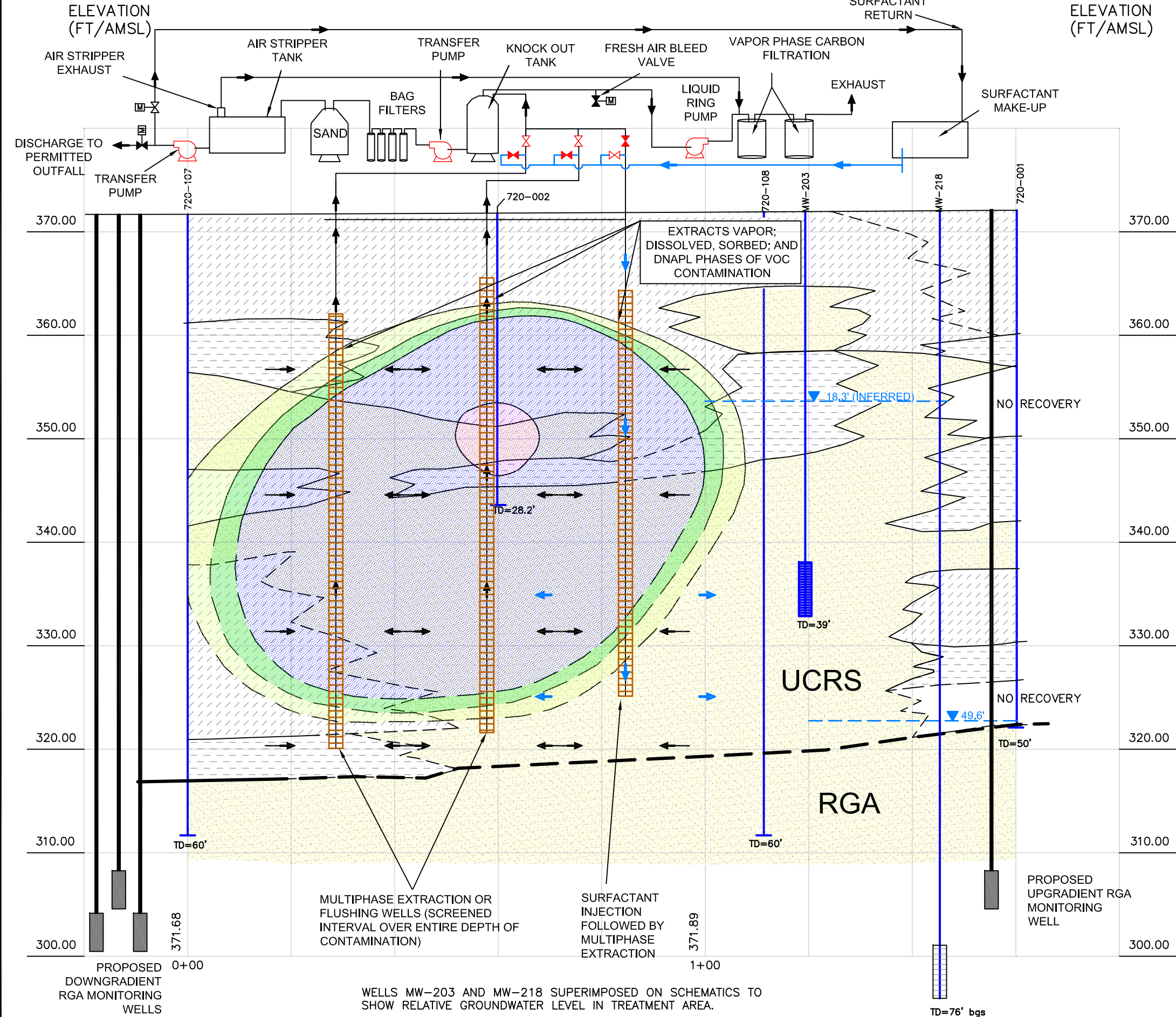

**LOCATION MAP**  
SCALE: 1" = 150'

**LEGEND**

- |  |                          |  |  |
|--|--------------------------|--|--|
|  | CLAY                     |  | EXISTING UCRS WELL SCREEN                |
|  | SAND                     |  | WATER LEVEL AT TIME OF GEOPHYSICAL LOG   |
|  | SILT                     |  | UCRS - UPPER CONTINENTAL RECHARGE SYSTEM |
|  | NO RECOVERY              |  | RGA - REGIONAL GRAVEL AQUIFER            |
|  | PROPOSED RGA WELL SCREEN |  | OPEN VALVE                               |
|  | EXISTING RGA WELL SCREEN |  | CLOSED VALVE                             |
|  |                          |  | DASHED WHERE INFERRED                    |

NOTE: NO RECOVERY, LITHOLOGY INFERRED BASED ON DRILLING METHOD OR BORING RECORD NOTES.

**TCE SOIL CONCENTRATION**

- |  |                    |  |                       |  |                 |
|--|--------------------|--|-----------------------|--|-----------------|
|  | 90 - 999 µg/kg     |  | 10,000 - 49,000 µg/kg |  | > 100,000 µg/kg |
|  | 1000 - 9,999 µg/kg |  | 50,000 - 99,999 µg/kg |  |                 |

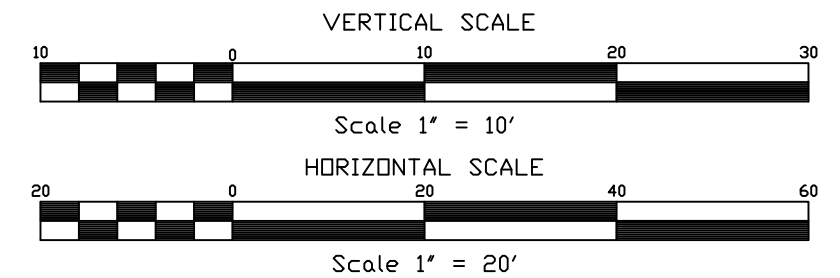

	U.S. DEPARTMENT OF ENERGY DOE PORTSMOUTH/PADUCAH PROJECT OFFICE PADUCAH GASEOUS DIFFUSION PLANT		
	Figure 3.14. <b>Schematic View of Alternative 7 – In situ Soil Flushing and Source Treatment Using Multiphase Extraction with Interim Land Use Controls</b>		
FILE NAME:	PROJECT #:	SCALE:	DATE:
FIG 3-14	11105	AS NOTED	1/4/2011

**THIS PAGE INTENTIONALLY LEFT BLANK**

3-39

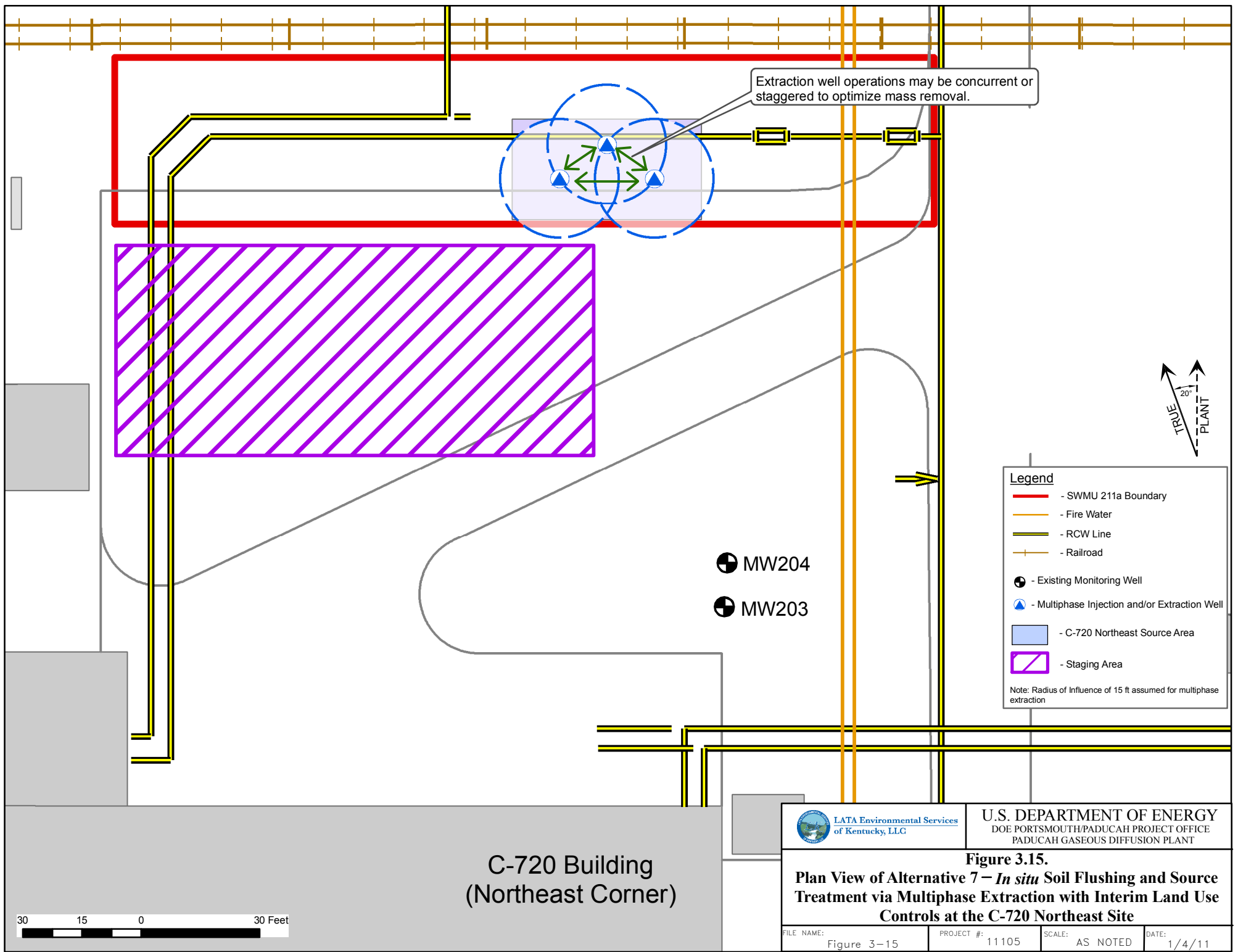

Extraction well operations may be concurrent or staggered to optimize mass removal.



**Legend**

- - SWMU 211a Boundary
- - Fire Water
- - RCW Line
- - Railroad
- - Existing Monitoring Well
- ▲ - Multiphase Injection and/or Extraction Well
- - C-720 Northeast Source Area
- ▨ - Staging Area

Note: Radius of Influence of 15 ft assumed for multiphase extraction

● MW204  
 ● MW203

C-720 Building  
 (Northeast Corner)

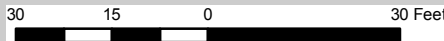

U.S. DEPARTMENT OF ENERGY  
 DOE PORTSMOUTH/PADUCAH PROJECT OFFICE  
 PADUCAH GASEOUS DIFFUSION PLANT

**Figure 3.15.**  
**Plan View of Alternative 7 – *In situ* Soil Flushing and Source Treatment via Multiphase Extraction with Interim Land Use Controls at the C-720 Northeast Site**

FILE NAME: Figure 3-15	PROJECT #: 11105	SCALE: AS NOTED	DATE: 1/4/11
---------------------------	---------------------	--------------------	-----------------







C-720 Building  
(Southeast Corner)

Extraction well operations may be concurrent or staggered to optimize mass removal.

MW218

**Legend**

- - SWMU 211b Boundary
- - Storm Water
- - Sanitary Water
- - Electrical
-  - Existing Monitoring Well
-  - Multiphase injection and/or extraction well
-  - C-720 Southeast Source Area
-  - Staging Area

Note: Radius of Influence of 15 ft assumed for multiphase extraction.

3-40

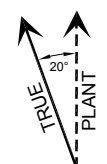
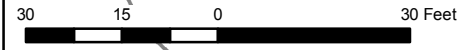
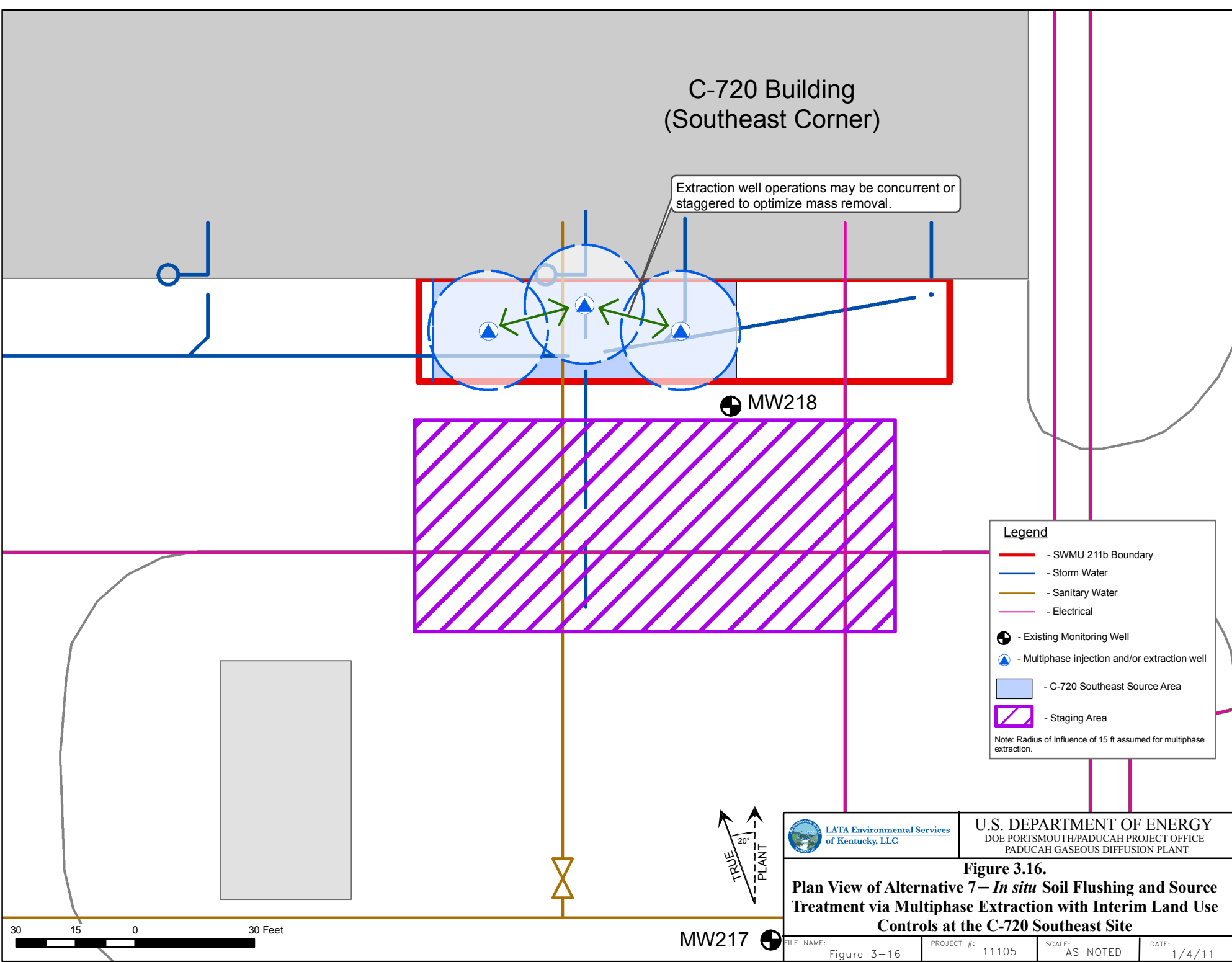

MW217



U.S. DEPARTMENT OF ENERGY  
DOE PORTSMOUTH/PADUCAH PROJECT OFFICE  
PADUCAH GASEOUS DIFFUSION PLANT

**Figure 3.16.**  
**Plan View of Alternative 7— *In situ* Soil Flushing and Source Treatment via Multiphase Extraction with Interim Land Use Controls at the C-720 Southeast Site**

FILE NAME: Figure 3-16	PROJECT #: 11105	SCALE: AS NOTED	DATE: 1/4/11
---------------------------	---------------------	--------------------	-----------------

Section 2.2, supplemental investigations to delineate the lateral and vertical extent of VOC contamination at the source areas would be completed as described for Alternative 3. The RDSI would be based on a systematically planned approach. The conceptual design for the RDSI includes these elements:

- Preliminary soil gas sampling using the MIP and on-site analysis for VOCs at the C-720 Area Northeast and Southeast Sites to estimate the areal and vertical extent of contamination including DNAPL.
- Soil coring using DPT and analysis for VOCs using EPA SW-846 Method 8260B or equivalent at locations that have been identified using the MIP results. Soil cores also would be evaluated to determine the presence or absence of DNAPL.
- Installation of dedicated soil gas monitoring points using DPT and sampling and analysis for VOCs. Dedicated soil gas monitoring points would be used to monitor air pressure and vapor concentrations during multiphase extraction.
- Civil survey of all sampling locations.

Air permeability testing for each site, as needed. The information available from Phase I of the C-400 Interim Action may be sufficient to support design. Air permeability testing would consist of installing at least one 4-inch vapor extraction well and applying vacuum using a skid-mounted blower and off-gas treatment system. Air pressure would be monitored using transducers or pressure gauges installed on the dedicated soil gas monitoring points or additional 10.16-cm (4-inch) wells. The radial pressure distribution observed in the air permeability test would be used to determine the required venting well spacing.

- Bench-scale testing, as needed. Bench-scale testing potentially would be conducted to determine the optimum surfactant solution for the site-specific soil types and DNAPL composition. Bench-scale testing results reported in the *Bench scale In situ Chemical Oxidation Studies of Trichloroethene in Waste Area Grouping 6 at the Paducah Gaseous Diffusion Plant, Paducah, Kentucky*, DOE/OR/07-1788&D1, (DOE 1999c) would be used to the extent possible.

The primary design elements that would be taken into consideration if multiphase extraction were implemented at the C-720 Northeast or Southeast Sites include the following:

- Radius of influence and the associated location and number of injection points
- The amount and type of surfactant to be used
- Design of the off-gas and groundwater treatment systems

#### **3.4.7.2 Surfactant-enhanced soil flushing**

*In situ* surfactant-enhanced soil flushing would be used to increase the treatment efficiency of the multiphase extraction process. Surfactant-enhanced soil flushing is a source zone remediation technology typically used to remove the undissolved, residual-phase contamination (i.e., DNAPLs) from which the dissolved-phase plume is derived. A surfactant, or “surface active” agent, is a wetting agent capable of reducing the surface tension of a liquid or the interfacial tension between two liquids (i.e., DNAPL and water), thereby increasing the surface area for solubilization. Surfactant-enhanced soil flushing would facilitate contaminant removal by two primary mechanisms: first, through enhancing the mobility of the contaminant by reducing interfacial tension; and secondly, by increasing contaminant solubility. Contaminant mobility, increased by interfacial tension reduction, would allow the DNAPL to flow more readily through the subsurface and be removed by the high vacuum extraction methods implemented

during multiphase extraction. Contaminant solubility also would increase by the formation of micro-emulsions. Aerobic biodegradation also may be enhanced during the soil flushing process, as surfactants are considered a co-metabolite to aerobic hydrocarbon digesting microbes. Following surfactant injection, the vacuum-enhanced multiphase extraction process would be utilized to extract the mobilized contaminant, surfactant, and the micro-emulsions formed during this process. The extracted surfactant and groundwater would be passed through the co-produced groundwater treatment system (see Section 3.4.7.5 for details). The treated groundwater and surfactant then would be reinjected, as necessary, to utilize the surfactant through multiple injection events. Multiphase extraction wells would be designed to operate in either extraction or injection mode to limit the distances that must be travelled for system capture.

### **3.4.7.3 Multiphase extraction**

Preliminary air permeability testing may be required to determine optimum well spacing, vacuum, and extraction rate. Testing may not be necessary due to results collected as part of the extraction activities conducted during Phase I of the C-400 Interim Remedial Action. Screen placement would be determined by lithology, water saturation, and TCE concentrations. Preliminary conceptual design of the multiphase extraction system includes the following:

- Multiphase extraction wells spaced assuming a 15 ft radius of influence. This estimate may be refined based on preliminary air permeability testing results, if performed.
- An extraction rate of approximately 10 standard ft<sup>3</sup> per minute per extraction well, manifolded to one blower per site. This estimate may be refined based on preliminary air permeability testing results, if performed.
- 4-inch schedule 40 PVC well casings would be screened throughout the zone of contamination in the UCRS. Thirty ft of screen per well was assumed for conceptual design; however, this value may be revised based on preliminary air permeability testing results. Larger diameter well casings could be used, if determined during the RD, to improve performance.
- A liquid ring pump would be utilized for high-vacuum extraction of materials.

The multiphase extraction system initially would be operated continuously. Soil gas concentrations in dedicated drive points and off-gas concentrations in individual wells would be monitored to optimize operations. Air flow from individual wells could be increased, reduced, or shut off depending on monitoring results. Additional performance enhancements, including passive recharge wells, could be implemented depending on results.

As concentrations of VOCs in off-gas decreased over time, the system could be operated in a pulsed pumping mode, to allow concentrations in soil gas to approach equilibrium levels before removal. When concentrations of VOCs in off-gas become asymptotic and show little or no rebound during pulsed pumping, this may be indicative of the need to begin system shut-down.

### **3.4.7.4 Off-gas treatment**

Off-gas treatment would be required to meet air emission ARARs. Equilibrium partitioning of DNAPL TCE and soil air was assumed for conceptual design purposes.

Electrical supply and natural gas requirements for off-gas treatment also are provided. Natural gas would be used to heat the extracted vapor prior to passing through the carbon vessels. The preliminary

conceptual design of the multiphase extraction off-gas treatment system for each site includes the following:

- Knock out tank. A knock out tank would be utilized to perform a crude disengagement of the gas and liquid extracted during the multiphase extraction process.
- Vapor Phase Carbon. Following the knock out tank, vapor would be passed through activated carbon vessels to adsorb contamination present in the vapor phase before being discharged through an exhaust.

#### **3.4.7.5 Coproduced groundwater treatment**

Coproduced groundwater would be treated to meet liquid effluent ARARs and discharged. Recovery rates would be expected to decrease over time as the formation drained.

The preliminary conceptual design for coproduced groundwater treatment includes the following:

- Knock out tank. A knock out tank would be utilized to perform a crude disengagement of the gas and liquid extracted during the multiphase extraction process.
- Surfactant make-up tank. A surfactant make-up tank initially would be used to store unused surfactant. As reinjection events occur, the tank would be used to store the treated groundwater-surfactant mixture.
- Filtration. Contaminated groundwater would be passed through bag filters and a sand filtration unit to eliminate solids.
- Air Stripper. Following the bag filters and sand filter unit, the extracted groundwater/surfactant mixture would be passed through an air stripper to remove organic volatile contamination present in the groundwater prior to either being reinjected into the UCRS or discharged.

It is reasonably expected that the Southwest Plume project effluent will meet all AWQC in the receiving stream if the concentration of TCE and the specified degradation products are at or below the Kentucky numeric water quality criteria for fish consumption, specified in Table I of 401 *KAR* 10:031 Section 6(1). There are no waste load allocations approved by EPA pursuant to 40 *CFR* § 130.7 for the receiving stream (Bayou Creek) that would impact effluent limits based on the numeric water quality criteria for fish consumption specified in Table I of 401 *KAR* 10:031 Section 6(1). Effluent from the treatment system would be sampled consistent with ARARs to ensure compliance.

#### **3.4.7.6 Sampling and Monitoring**

Soil moisture content, water levels, and soil gas VOC concentrations in the UCRS would be monitored. Piezometers and neutron probe access tubes would be installed in the UCRS to the top of the RGA. Water levels and soil moisture contents would be monitored at least quarterly for the first year.

Sampling of multiphase extraction off-gas and dedicated soil gas points would be required for process optimization (e.g., to determine when to shut off individual extraction wells, when to switch to pulsed pumping, when to turn off the system, etc.). An operational sampling and monitoring plan would be prepared in the RD/RAWP. The preliminary conceptual design for soil vapor sampling and soil vapor monitoring includes the following:

- Weekly soil vapor off-gas sampling and analysis for VOCs; and
- Monthly soil gas dedicated drive point sampling and analysis for VOCs.

In addition, one upgradient and three downgradient wells, screened in the shallow RGA, would be constructed at each source area. Wells would be monitored at a frequency to be determined for VOCs, pH, conductivity, water levels, and potentially other analytes, as needed. All constituents sampled would be included in the RAWP. Results would be reported as part of the five-year reviews and provided to the sitewide environmental monitoring program and to the Dissolved-Phase Plumes Remedial Action Project under the Groundwater OU. MWs would remain in place until soil RGs were attained.

#### **3.4.7.7 Operation and Maintenance**

O&M for Alternative 7 would consist of the following:

- Inspecting and maintaining multiphase extraction blowers;
- Inspecting and maintaining bag filtration and sand filtration units;
- Carbon replacement;
- Periodic removal and disposal of filter solids; and
- Monitoring air and water discharge.

#### **3.4.7.8 Confirmatory sampling**

Confirmatory sampling in the treatment area would be required to determine posttreatment TCE soil concentrations. A confirmatory sampling plan would be prepared during RAWP development. The conceptual design for confirmatory sampling includes soil coring using DPT and analysis for VOCs using EPA SW-846 Method 8260B or equivalent. Depths and locations of cores would be determined based on the results of the RDSI.

#### **3.4.7.9 Secondary waste management**

Secondary wastes would include coproduced groundwater, spent carbon, drill cuttings (produced during multiphase well installation), PPE, and decontamination fluids. Coproduced groundwater would be treated and discharged, as described previously. Spent GAC would be shipped off-site for regeneration. For cost-estimating purposes, drill cuttings, PPE, and decontamination fluids were assumed to require containerization, dewatering, and testing prior to off-site disposal. Actual dispositioning requirements would be determined by sampling of containerized soils. All secondary wastes would be managed in accordance with all ARARs.

#### **3.4.7.10 Site restoration**

Site restoration activities prior to remedy completion would include demobilizing and removing all RDSI equipment, sealing all MIP and soil coring locations with bentonite, reseeding disturbed vegetated areas at the C-720 Northeast Site, and repairing penetrations of asphalt and concrete at the C-720 Northeast and Southeast Sites.

Multiphase extraction wells would remain in place through the O&M period. Monitoring wells would remain in place until soil RGs were attained.

#### **3.4.7.11 Interim LUCs**

Interim LUCs (E/PP program and warning signs), as described for Alternative 2, would be implemented.

### 3.4.7.12 Five-year reviews

Five-year reviews, as described for Alternative 2, would be implemented as long as soil contaminant concentrations remained above RGs.

### 3.4.8 Alternative 8—*In situ* Source Treatment Using Enhanced *In situ* Bioremediation (EISB) with Interim LUCs

Alternative 8 consists of the following:

- RDSI
- Installation of deep and shallow gravity feed wells (The gravity feed wells would initially be used to gravity feed a bioamendment into the subsurface. The wells could be equipped for potential use as injection/extraction wells, to be used as necessary.)
- Installation of infiltration trench and “herring-bone” design horizontal infiltration wells
- Introduction of bioamendment into the subsurface
- Reintroduction of bioamendment into the subsurface and recirculation of bioamendment, as needed.
- Site restoration
- Confirmatory Sampling
- Secondary waste management
- Interim LUCs (i.e., warning signs and E/PP program)
- Groundwater monitoring
- Five-year reviews

This alternative would reduce the mass of VOCs present in the Oil Landfarm source area and eliminate risks to receptors by eliminating the exposure pathways shown in Figure 1.19. The presence of daughter products of anaerobic biodegradation of chlorinated solvents and other markers of anaerobic biodegradation (i.e., carbon disulfide) indicate conditions potentially suitable for anaerobic biodegradation are present at some locations in the vicinity of the Oil Landfarm and may be amenable to additional biostimulation.

The conceptual design described in the following sections relies heavily on the introduction of a bioamendment through the use of a horizontal infiltration gallery at the original location of VOC contamination release into the subsurface. The original VOC migration pathways are well known in the case of the Oil Landfarm, but not necessarily at the C-720 sites. In addition, due to the presence of subsurface utilities and concrete surface cover, horizontal infiltration galleries are not considered technically implementable at the C-720 Sites. For these reasons, Alternative 8 is screened out of further evaluation at the C-720 Northeast and Southeast Sites. Requirements and conceptual designs for each element of Alternative 8 are discussed below in detail. A schematic view of the conceptual design is provided in Figure 3.17, and a plan view of the area that would be treated at the Oil Landfarm is shown in Figure 3.18.

**THIS PAGE INTENTIONALLY LEFT BLANK**

**B**  
NORTHWEST  
ELEVATION  
(FT/AMSL)

**B'**  
NORTHEAST  
ELEVATION  
(FT/AMSL)

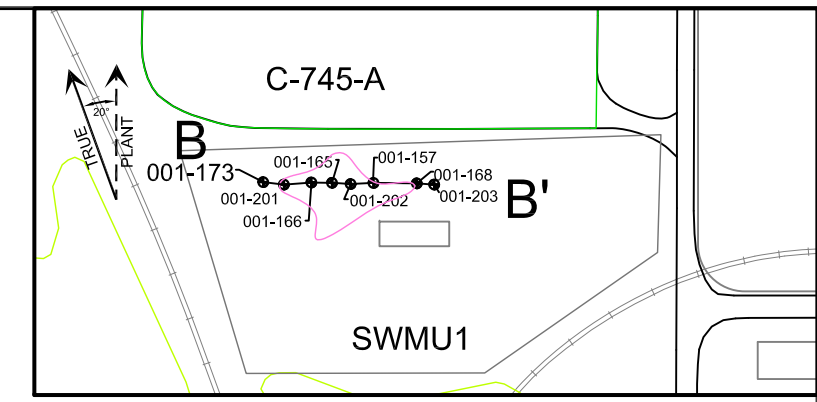

**LOCATION MAP**  
SCALE: 1" = 200'

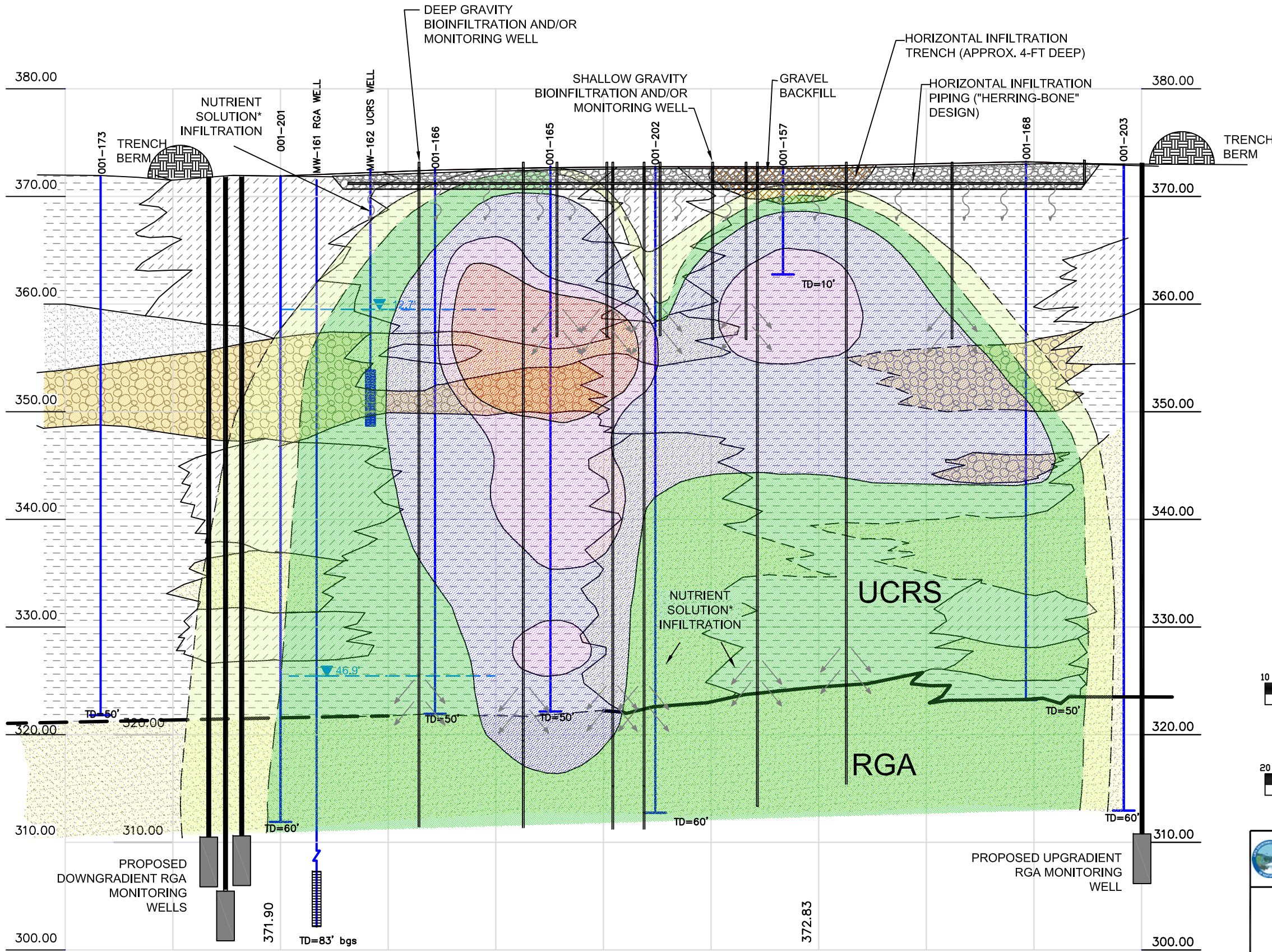

**LEGEND**

- GRAVEL
- CLAY
- SAND
- SILT
- FILL
- PROPOSED RGA WELL SCREEN
- EXISTING RGA WELL SCREEN
- EXISTING UCRS WELL SCREEN
- UCRS - UPPER CONTINENTAL RECHARGE SYSTEM
- RGA - REGIONAL GRAVEL AQUIFER
- WATER LEVEL AT TIME OF GEOPHYSICAL LOG
- DASHED WHERE INFERRED

**TCE SOIL CONCENTRATION**

- 90 - 999 µg/kg
- 1000 - 9,999 µg/kg
- 10,000 - 49,000 µg/kg
- 50,000 - 99,999 µg/kg
- > 100,000 µg/kg symbol"/> > 100,000 µg/kg

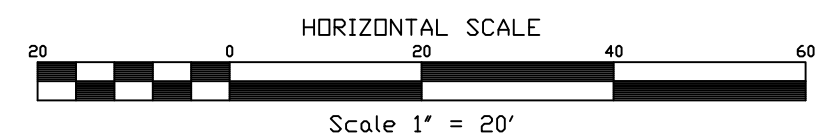
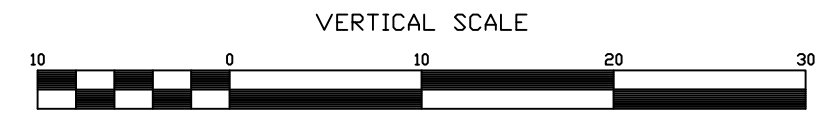

0+00 WELLS MW-161 AND MW-162 PROJECTED ON SCHEMATICS TO SHOW APPROXIMATE GROUNDWATER LEVEL IN TREATMENT AREA.

\*NUTRIENT SOLUTION IS A MIXTURE OF MICROBES, NUTRIENTS, AND LACTATE REDUCTANT.

U.S. DEPARTMENT OF ENERGY  
DOE PORTSMOUTH/PADUCAH PROJECT OFFICE  
PADUCAH GASEOUS DIFFUSION PLANT

**Figure 3.17.**  
**Schematic View of Alternative 8 – In situ Source Treatment Using EISB with Interim Land Use Controls**

FILE NAME: Fig 3-17	PROJECT #: 11105	SCALE: AS NOTED	DATE: 1/4/2011
---------------------	------------------	-----------------	----------------



**THIS PAGE INTENTIONALLY LEFT BLANK**

3-49

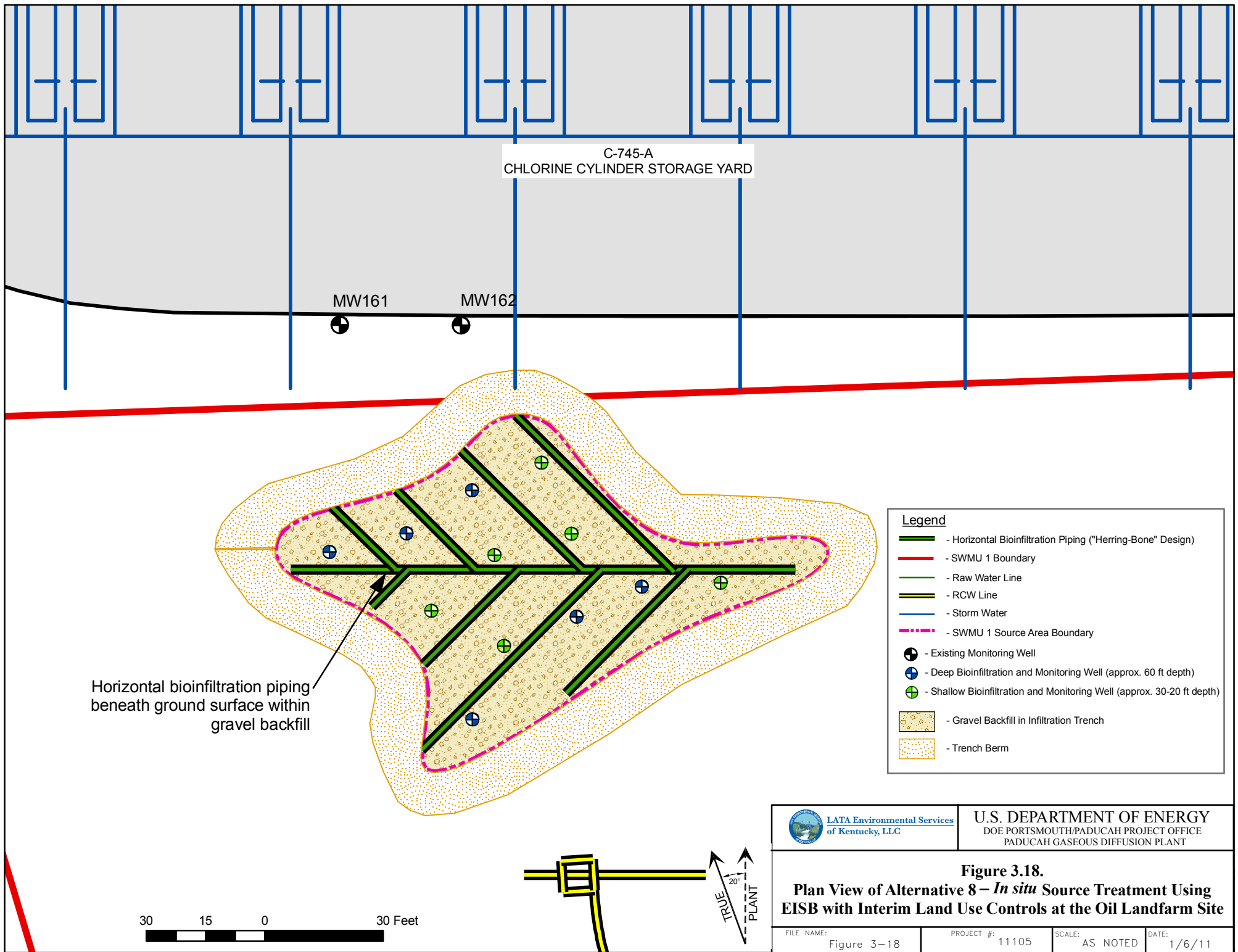

Horizontal bioinfiltration piping beneath ground surface within gravel backfill

**Legend**

- Horizontal Bioinfiltration Piping ("Herring-Bone" Design)
- SWMU 1 Boundary
- Raw Water Line
- RCW Line
- Storm Water
- SWMU 1 Source Area Boundary
- Existing Monitoring Well
- Deep Bioinfiltration and Monitoring Well (approx. 60 ft depth)
- Shallow Bioinfiltration and Monitoring Well (approx. 30-20 ft depth)
- Gravel Backfill in Infiltration Trench
- Trench Berm

	U.S. DEPARTMENT OF ENERGY DOE PORTSMOUTH/PADUCAH PROJECT OFFICE PADUCAH GASEOUS DIFFUSION PLANT		
	<b>Figure 3.18.</b> <b>Plan View of Alternative 8 – <i>In situ</i> Source Treatment Using EISB with Interim Land Use Controls at the Oil Landfarm Site</b>		
FILE NAME:	PROJECT #:	SCALE:	DATE:
Figure 3-18	11105	AS NOTED	1/6/11

### 3.4.8.1 RDSI

An RDSI would be performed at the Oil Landfarm to better determine the extent and distribution of VOCs, including DNAPL TCE, and to determine UCRS soil and groundwater parameters specific to the EISB technology. Based on the calculated RGs for VOC concentrations in source area soil presented in Section 2.2, supplemental investigations to delineate the lateral and vertical extent of VOC contamination at the source areas would be completed as described for Alternative 3. The RDSI would be based on a systematically planned approach.

The conceptual design for the RDSI at the Oil Landfarm includes the following:

- Preliminary soil gas sampling using the MIP and on-site analysis for VOCs at Oil Landfarm to estimate the areal and vertical extent of contamination including DNAPL;
- Soil coring using DPT and analysis for VOCs using EPA SW-846 Method 8260B or equivalent at locations that have been identified using the MIP results. Soil cores also would be evaluated to determine the presence or absence of DNAPL;
- Sampling of existing UCRS wells in the vicinity of the source areas and analysis for EISB parameters including VOCs, pH, oxidation reduction potential (ORP), dissolved oxygen, total and dissolved iron, total and dissolved manganese, sulfate, nitrate, methane, ethene, ethane, alkalinity, total organic carbon, and microbiological parameters; and
- Civil survey of all sampling and well locations.

### 3.4.8.2 Installation of gravity feed EISB system

A gravity feed EISB system would be installed to introduce the bioamendment into the subsurface. The system would utilize two gravity injection techniques designed to horizontally and vertically distribute the bioamendment into the UCRS. These techniques would consist of the following elements:

- **Horizontal infiltration gallery.** This injection technique would consist of a trench approximately 4 ft deep backfilled with gravel coupled with horizontal wells installed within the trench in a “herring-bone” design (Figure 3.18). The excavated material would be characterized and managed and disposed of appropriately in accordance with ARARs. A berm surrounding the trench would be constructed. The horizontal infiltration gallery would increase effectiveness in the unsaturated vadose zone by raising the saturation levels while allowing the bioamendment mixture to infiltrate downward by gravity. The trench would be installed to cover the areal extent of the source area. At the Oil Landfarm, the horizontal infiltration gallery would thereby essentially be installed at the original location of VOC contamination release into the subsurface. This location may be visibly located at the Oil Landfarm by the depression that has formed on the surface. At the Oil Landfarm source area, the bioamendments added to the trench would percolate into the subsurface and would be expected to follow the original migration pathways of the TCE. The horizontal wells would be used to feed bioamendment into the gravel trench, thereby horizontally distributing the amendment within the boundaries of the source area. Following saturation of trench with bioamendment, the mixture would be allowed to percolate into the subsurface of the UCRS. Periodic reinjection of bioamendment would occur, as needed. The schedule and requirements associated with reinjection events would be determined during the RD.
- **Vertical gravity feed wells.** Shallow and deep vertical wells would installed at approximately 20-30 ft deep and 40–50 ft deep, respectively, and would be installed to distribute the bioamendment into

contaminated areas at mid- and low-depths of the UCRS. The bioamendment would be allowed to gravity feed from these wells into the subsurface. Bioamendment would be fed through the wells on a periodic basis (to be determined during the RD). If it is determined during implementation of remedial action that recirculation of the bioamendment is essential, these wells could be used as injection/extraction wells. Because of the anticipated low permeability of most of the matrix materials, it is believed that a sequential injection/extraction would be more effective than recirculation.

#### **3.4.8.3 Introduction of bioamendment**

A bioamendment mixture (i.e., microbes, nutrients, and reductants) would be introduced into the subsurface via the horizontal infiltration gallery coupled with vertical gravity-feed wells. The bioamendment would be reintroduced on a periodic basis (to be determined during the RD and adjusted based upon ongoing monitoring of the performance of the bioremediation system). The specific bioamendment mixture would be determined using sample results from the RDSI. Due to characteristics that are similar to DNAPL, a lactate reductant potentially could be utilized to more efficiently imitate the DNAPL and follow similar migration pathways.

#### **3.4.8.4 Confirmatory sampling**

Confirmatory sampling in the treatment area would be required to determine posttreatment TCE soil concentrations. A confirmatory sampling plan would be prepared during RAWP development. The conceptual design for confirmatory sampling includes soil coring using DPT and analysis for VOCs using EPA SW-846 Method 8260B or equivalent. Depths and locations of cores would be determined based on the results of the RDSI.

#### **3.4.8.5 Secondary waste management**

Secondary wastes produced under this alternative would include drill cuttings, PPE, and decontamination fluids from the RDSI and purge water from groundwater monitoring. For cost-estimating purposes, drill cuttings, PPE, and decontamination fluids were assumed to require containerization, dewatering, and testing prior to off-site disposal. PCBs potentially present at the Oil Landfarm would be expected to occur at concentrations below 50 ppm and would not require management as TSCA waste. Groundwater monitoring purge water would either be used as makeup water or containerized and treated on-site prior to discharge. Actual disposal requirements would be determined by sampling of containerized soils, decontamination fluids and purge water. All secondary wastes would be managed in accordance with all ARARs.

#### **3.4.8.6 Site restoration**

Site restoration activities would include demobilizing and removing all equipment; backfilling the horizontal infiltration trenches, if desired; sealing all MIP, soil coring, and electron donor injection locations with bentonite; and reseeding disturbed vegetated areas at the Oil Landfarm. Monitoring wells would be left in place until soil RGs were attained.

#### **3.4.8.7 Interim LUCs**

Interim LUCs (E/PP program and warning signs), as described for Alternative 2, would be implemented.

### 3.4.8.8 Groundwater monitoring

Groundwater monitoring would be used to determine the effectiveness of the remedy. One upgradient and three downgradient wells, screened in the shallow RGA, would be constructed at each source area. Wells initially would monitor for VOCs, oxygen, nitrate, sulfate, iron, manganese, chloride, organic acids, pH, ORP, alkalinity, water levels, and other parameters, as needed, to support the design of the EISB system. Wells would be monitored thereafter for VOCs at a frequency to be determined during RD on an as needed basis to demonstrate remedial action performance. Results would be reported as part of the five-year reviews and provided to the sitewide environmental monitoring program and to the Dissolved-Phase Plumes Remedial Action Project under the Groundwater OU. MWs would remain in place until soil RGs were attained.

### 3.4.8.9 Five-year reviews

Five-year reviews, as described for Alternative 2, would be implemented as long as soil contaminant concentrations remained above RGs.

## 3.5 SCREENING OF ALTERNATIVES

Alternatives are screened in this section, using the process described in CERCLA guidance (EPA 1988) and the NCP, to reduce the number of alternatives carried forward to detailed analysis. As an initial screening (Table 3.2), Alternatives 6 and 7 are screened out of further evaluation at the Oil Landfarm due to the high relative cost. Alternatives 3, 4, and 8 are screened out of further evaluation at the C-720 Northeast and Southeast Sites on the basis of low technical implementability in comparison to other alternatives.

**Table 3.2. Initial Alternative Screening**

Alternative	Oil Landfarm	C-720 NE	C-720 SE
Alternative 1—No further action	✓	✓	✓
Alternative 2—Long term monitoring with interim land use controls (LUCs)	✓	✓	✓
Alternative 3— <i>In situ</i> source treatment using deep soil mixing with interim LUCs	✓	—	—
Alternative 4—Source removal and <i>in situ</i> chemical source treatment with interim LUCs	✓	—	—
Alternative 5— <i>In situ</i> thermal treatment with interim LUCs	✓	✓	✓
Alternative 6— <i>In situ</i> source treatment using liquid atomized injection (LAI) with interim LUCs	—	✓	✓
Alternative 7— <i>In situ</i> soil flushing and source treatment via multiphase extraction with interim LUCs	—	✓	✓
Alternative 8— <i>In situ</i> source treatment using enhanced <i>in situ</i> bioremediation (EISB) with interim LUCs	✓	—	—

✓ = Alternative included in more-detailed screening process.

— = Alternative screened out through initial process.

Alternatives are screened further with respect to effectiveness, implementability, and cost. The evaluation of effectiveness considers reductions in toxicity, mobility, and volume of VOCs. The evaluation of implementability considers technical feasibility criteria, including the ability to construct, operate, and maintain the remedy, and administrative feasibility criteria, including the ability to obtain required regulatory approvals. Evaluation of cost for the alternatives is based on the relative capital and O&M costs for the primary technologies utilized, as identified in Table A.2.

Table 3.3 summarizes the results of screening. Alternatives with the best combinations of effectiveness and implementability and the lowest costs are retained for detailed analysis in Section 4 and comparative analysis in Section 5. Alternatives 1, 2, 3, 4, 5, and 8 are advanced to detailed analysis at the Oil Landfarm. Alternatives 1, 2, 5, 6, and 7 are advanced to detailed analysis at the C-720 Northeast and Southeast Sites.

**Table 3.3. Summary of Screening of Alternatives\***

<b>Preliminary ranking of alternatives for the Oil Landfarm Site</b>								
	<b>Alternative 1</b>	<b>Alternative 2</b>	<b>Alternative 3</b>	<b>Alternative 4</b>	<b>Alternative 5</b>	<b>Alternative 6</b>	<b>Alternative 7</b>	<b>Alternative 8</b>
<b>Balancing Criteria</b>	No Further Action	Long-term Monitoring	<i>In situ</i> Treatment Using Deep Soil Mixing	Source Removal and <i>In situ</i> Chemical Source Treatment	<i>In situ</i> Thermal Source Treatment	<i>In situ</i> Source Treatment Using LAI	<i>In situ</i> Soil Flushing and Source Treatment Using Multiphase Extraction	<i>In situ</i> Source Treatment Using EISB
Reduction in toxicity, mobility, or volume through treatment	Low (1)	Low (1)	Moderate to High (7)	High (9)	High (9)	NA	NA	Moderate to High (7)
Short-term effectiveness	Low (1)	Moderate to Low (3)	Moderate to High (7)	Moderate (5)	Moderate (5)	NA	NA	Moderate to Low (3)
Long-term effectiveness	Low (1)	Moderate to Low (3)	Moderate to High (7)	Moderate to High (7)	Moderate to High (7)	NA	NA	Moderate (5)
Overall implementability	High (9)	High (9)	Moderate (5)	Moderate to Low (3)	Moderate to Low (3)	NA	NA	Moderate to High (7)
Overall cost rating**	High (9)	High (9)	Moderate to Low (3)	Low (1)	Low (1)	NA	NA	High (9)
<b>Average Rating:</b>	<b>4.2</b>	<b>5</b>	<b>5.8</b>	<b>5</b>	<b>5</b>	NA	NA	<b>6.2</b>

**Table 3.3. Summary of Screening of Alternatives (Continued)\***

<b>Preliminary ranking of alternatives for the C-720 Northeast Site</b>								
	<b>Alternative 1</b>	<b>Alternative 2</b>	<b>Alternative 3</b>	<b>Alternative 4</b>	<b>Alternative 5</b>	<b>Alternative 6</b>	<b>Alternative 7</b>	<b>Alternative 8</b>
<b>Balancing Criteria</b>	No Further Action	Long-term Monitoring	<i>In situ</i> Treatment Using Deep Soil Mixing	Source Removal and <i>In situ</i> Chemical Source Treatment	<i>In situ</i> Thermal Source Treatment	<i>In situ</i> Source Treatment Using LAI	<i>In situ</i> Soil Flushing and Source Treatment Using Multiphase Extraction	<i>In situ</i> Source Treatment Using EISB
Reduction in toxicity, mobility, or volume through treatment	Low (1)	Low (1)	NA	NA	High (9)	Moderate to High (7)	High (9)	NA
Short-term effectiveness	Low (1)	Moderate to Low (3)	NA	NA	Moderate to High (7)	Moderate (5)	Moderate to High (7)	NA
Long-term effectiveness	Low (1)	Moderate to Low (3)	NA	NA	Moderate to High (7)	Moderate (5)	Moderate to High (7)	NA
Overall Implementability	High (9)	High (9)	NA	NA	Low (1)	Moderate (5)	Moderate to Low (3)	NA
Overall Cost Rating**	High (9)	High (9)	NA	NA	Low (1)	Moderate to Low (3)	Moderate to Low (3)	NA
<b>Average Rating:</b>	<b>4.2</b>	<b>5</b>	NA	NA	<b>5</b>	<b>5</b>	<b>5.8</b>	NA



Table 3.3. Summary of Screening of Alternatives (Continued)\*

Preliminary ranking of alternatives for the C-720 Southeast Site								
	Alternative 1	Alternative 2	Alternative 3	Alternative 4	Alternative 5	Alternative 6	Alternative 7	Alternative 8
<b>Balancing Criteria</b>	No Further Action	Long-term Monitoring	<i>In situ</i> Treatment Using Deep Soil Mixing	Source Removal and <i>In situ</i> Chemical Source Treatment	<i>In situ</i> Thermal Source Treatment	<i>In situ</i> Source Treatment Using LAI	<i>In situ</i> Soil Flushing and Source Treatment Using Multiphase Extraction	<i>In situ</i> Source Treatment Using EISB
Reduction in toxicity, mobility, or volume through treatment	Low (1)	Low (1)	NA	NA	High (9)	Moderate to High (7)	High (9)	NA
Short-term effectiveness	Low (1)	Moderate to Low (3)	NA	NA	Moderate to High (7)	Moderate (5)	Moderate to High (7)	NA
Long-term effectiveness	Low (1)	Moderate to Low (3)	NA	NA	Moderate to High (7)	Moderate (5)	Moderate to High (7)	NA
Overall Implementability	High (9)	High (9)	NA	NA	Low (1)	Moderate to Low (3)	Low (1)	NA
Overall Cost Rating**	High (9)	High (9)	NA	NA	Low (1)	Moderate to Low (3)	Moderate to Low (3)	NA
<b>Average Rating:</b>	<b>4.2</b>	<b>5</b>	NA	NA	<b>5</b>	<b>4.6</b>	<b>5.4</b>	NA

\*Alternatives 2 through 8 include use of interim LUCs.

\*\*A high overall cost rating corresponds to a low project cost relative to the site evaluated.

NA – Not Applicable. Alternative not retained for further analysis at the associated site due to reasons described in Section 3.5.

LAI – Liquid atomization injection

EISB – Enhanced *in situ* bioremediation

Alternative Rating Guide:

Balancing criteria are scored from 1 (worst) to 9 (best) for each alternative. The qualitative and numerical ratings correspond as follows:

9 – High

7 – Moderate to High

5 – Moderate

3 – Moderate to Low

1 – Low

## **4. DETAILED ANALYSIS OF ALTERNATIVES**

Remedial alternatives developed in Section 3 and retained after screening are analyzed in detail in this section. Results of this analysis will form the basis for comparing alternatives and for preparing the Proposed Plan.

### **4.1 INTRODUCTION**

#### **4.1.1 Purpose of the Detailed Analysis**

The remedial action alternatives developed in Section 3 are analyzed in detail against the seven CERCLA threshold and balancing criteria to form the basis for selecting a final remedial action. The intent of this analysis is to present sufficient information to allow the EPA, KDEP, and DOE to select an appropriate remedy.

Alternatives are evaluated with respect to the seven CERCLA threshold and balancing criteria outlined in 40 *CFR* § 300.430(e)(9)(iii) and as discussed in Section 4.1.2. This evaluation is the basis for determining the ability of a remedial action alternative to satisfy CERCLA remedy selection requirements.

#### **4.1.2 Overview of the CERCLA Evaluation Criteria**

The CERCLA evaluation criteria include technical, administrative, and cost considerations; compliance with specific statutory requirements; and state and community acceptance. Overall protection of human health and the environment and compliance with ARARs are categorized as threshold criteria that any viable alternative must meet. Long-term effectiveness and permanence; reduction of toxicity, mobility, and volume through treatment; short-term effectiveness; implementability; and cost are considered balancing criteria upon which the detailed analysis is primarily based. State and community acceptance is evaluated following comment on the FFS and the Proposed Plan and is addressed as a final decision is made and the ROD is prepared. Each criterion is described below.

##### **4.1.2.1 Overall protection of human health and the environment**

Alternatives are assessed to determine whether they can adequately protect human health and the environment in both the short- and long-term from unacceptable risks posed by contaminants present at the Oil Landfarm and the C-720 Northeast and Southeast Sites by eliminating, reducing, or controlling exposures as established during the development of RAOs consistent with 40 *CFR* § 300.430(e)(2)(I). Overall protection of human health and the environment draws on the assessments of the other evaluation criteria, especially long-term effectiveness and permanence, short-term effectiveness, and compliance with ARARs.

##### **4.1.2.2 Compliance with ARARs**

Section 121(d) of CERCLA and NCP Section 300.430(f)(1)(ii)(B) require that remedial actions at CERCLA sites at least attain legally “applicable” or “relevant and appropriate” federal and state environmental requirements, standards, criteria, and limitations, which are collectively referred to as “ARARs,” unless such ARARs are waived under CERCLA Section 121(d)(4). ARARs include federal or more stringent state substantive environmental or facility siting laws/regulations; they do not include occupational safety protection requirements. Additionally, per 40 *CFR* § 300.405(g)(3), other advisories,

criteria, or guidance may be considered in determining remedies (TBC category). CERCLA 121(d)(4) provides several ARAR waiver options that may be invoked, provided that human health and the environment are protected. Activities conducted on-site must comply with the substantive but not administrative requirements. Administrative requirements include applying for permits, recordkeeping, consultation, and reporting. Activities conducted off-site must comply with both the substantive and administrative requirements of applicable laws. Measures required to meet ARARs will be incorporated into the design phase and implemented during the construction and operation phases of the remedial action.

ARARs are divided into three categories: (1) chemical-specific, (2) location-specific, and (3) action-specific (Tables 4.1 and 4.2). Chemical-specific ARARs provide health- or risk-based concentration limits or discharge limitations in various environmental media (i.e., surface water, groundwater, soil, or air) for specific hazardous substances, pollutants, or contaminants. Location-specific ARARs establish restrictions on permissible concentrations of hazardous substances or establish requirements for how activities will be conducted because they are in special locations (e.g., floodplains or historic districts). Action-specific ARARs include operation, performance, and design of the preferred alternative based on waste types and/or media to be addressed and removal/remedial activities to be implemented.

There are no chemical-specific ARARs for remediation of the contaminated soils at the source areas; however, Kentucky drinking water standard MCLs at 401 KAR 8:420 for VOCs were used for calculation of soil RGs. Action and location-specific ARARs are further identified in each alternative.

Alternatives are assessed to determine whether they meet ARARs identified for each alternative. If ARARs will not be met at the end of an action, an evaluation will occur to determine when a basis exists for invoking one of the ARAR waivers cited in 40 CFR § 300.430(f)(1)(ii)(c), that are listed here:

- The alternative is an interim measure and will become part of a total remedial action that will attain the applicable or relevant and appropriate federal or state requirement.
- Compliance with the requirement will result in greater risk to human health and the environment than other alternatives.
- Compliance with the requirement is technically impracticable from an engineering perspective.
- The alternative will attain a standard of performance that is equivalent to that required under the otherwise applicable standard, requirement, or limitation through use of another method or approach.
- With respect to a state requirement, the state has not consistently applied, or demonstrated the intention to consistently apply, the promulgated requirement in similar circumstances at other remedial actions within the state.

In addition to specific ARARs listed in this section, certain EPA guidance and policies on management of waste provides flexibility for management of waste within the AOC. Accordingly, EPA guidance (*Management of Remediation Waste under RCRA* EPA530-F-98-026, October 1998) on the AOC policy provides for certain discrete areas of generally dispersed contamination TBC RCRA units (usually landfills). Because an AOC is equated to a RCRA land-based unit, consolidation and *in situ* treatment of hazardous waste within the AOC do not create a new point of hazardous waste generation for purposes of RCRA. This interpretation allows wastes to be consolidated or treated *in situ* within an AOC without triggering land disposal restrictions or minimum technology requirements. The AOC interpretation may be applied to any hazardous remediation waste (including non-media wastes) that is in or on the land. The

**Table 4.1. Location-specific ARARs for the Oil Landfarm and the C-720 Northeast and Southeast Sites**

Location-specific ARARs						
Location	Requirement	Prerequisite	Citation	SWMU 1	C-720 NE	C-720 SE
<i>Cultural resources</i>						
Presence of wetlands as defined in 10 <i>CFR</i> § 1022.4	Avoid, to the extent possible, the long- and short-term adverse effects associated with destruction, occupancy, and modification of wetlands.	DOE actions that involve potential impacts to, or take place within, wetlands— <b>applicable</b> .	10 <i>CFR</i> § 1022.3(a)	✓	✓	✓
	Take action, to extent practicable, to minimize destruction, loss, or degradation of wetlands and to preserve and enhance the natural and beneficial values of wetlands.		10 <i>CFR</i> § 1022.3(a)(7) and (8)	✓	✓	✓
	Undertake a careful evaluation of the potential effects of any new construction in wetlands. Identify, evaluate, and, as appropriate, implement alternative actions that may avoid or mitigate adverse impacts on wetlands.		10 <i>CFR</i> § 1022.3(b) and (d)	✓	✓	✓
	Measures that mitigate the adverse effects of actions in a wetland including, but not limited to, minimum grading requirements, runoff controls, design and construction constraints, and protection of ecologically-sensitive areas.		10 <i>CFR</i> § 1022.13(a)(3)	✓	✓	✓
	If no practicable alternative to locating or conducting the action in the wetland is available, then before taking action design or modify the action in order to minimize potential harm to or within the wetland, consistent with the policies set forth in E.O. 11990.		10 <i>CFR</i> § 1022.14(a)	✓	✓	✓
Location encompassing aquatic ecosystem as defined in 40 <i>CFR</i> § 230.3(c)	Except as provided under section 404(b)(2), no discharge of dredged or fill material is permitted if there is a practicable alternative that would have less adverse impact on the aquatic ecosystem or if it will cause or contribute to significant degradation of the waters of the United States.	Action that involves the discharge of dredged or fill material into waters of the United States, including jurisdictional wetlands— <b>relevant and appropriate</b> .	40 <i>CFR</i> § 230.10(a) and (c)	✓	✓	✓

**Table 4.1. Location-specific ARARs for the Oil Landfarm and the C-720 Northeast and Southeast Sites (Continued)**

Location-specific ARARs						
Location	Requirement	Prerequisite	Citation	SWMU 1	C-720 NE	C-720 SE
	Except as provided under section 404(b)(2), no discharge of dredged or fill material shall be permitted unless appropriate and practicable steps have been taken that will minimize potential adverse impacts of the discharge on the aquatic ecosystem. <i>40 CFR § 230.70 et seq.</i> identifies such possible steps.		40 <i>CFR</i> § 230.10(d)	✓	✓	✓
Nationwide Permit Program	Must comply with the substantive requirements of the NWP 38, General Conditions, as appropriate.	Discharge of dredged or fill material into waters of the United States, including jurisdictional wetlands— <b>relevant and appropriate.</b>	Nation Wide Permit (38) Cleanup of Hazardous and Toxic Waste 33 <i>CFR</i> § 323.3(b)	✓	✓	✓

**Table 4.2. Action-specific ARARs for the Oil Landfarm and the C-720 Northeast and Southeast Sites**

Action	Requirement	Prerequisite	Citation	Alt 2	Alt 3	Alt 4	Alt 5	Alt 6	Alt 7	Alt 8
<i>Site preparation, construction, and excavation activities</i>										
Activities causing fugitive dust emissions	<p>No person shall cause, suffer, or allow any material to be handled, processed, transported, or stored, a building or its appurtenances to be constructed, altered, repaired, or demolished, or a road to be used without taking reasonable precaution to prevent particulate matter from becoming airborne. Such reasonable precautions shall include, when applicable, but not be limited to, the following:</p> <ul style="list-style-type: none"> <li>• Use, where possible, of water or chemicals for control of dust in the demolition of existing buildings or structures, construction operations, the grading of roads or the clearing of land;</li> <li>• Application and maintenance of asphalt, oil, water, or suitable chemicals on roads, materials stockpiles, and other surfaces which can create airborne dusts;</li> <li>• Covering, at all times when in motion, open bodied trucks transporting materials likely to become airborne;</li> <li>• The maintenance of paved roadways in a clean condition; and</li> </ul> <p>The prompt removal of earth or other material from a paved street which earth or other material has been transported thereto by trucking or earth moving equipment or erosion by water.</p>	Fugitive emissions from land-disturbing activities (e.g., handling, processing, transporting or storing of any material, demolition of structures, construction operations, grading of roads, or the clearing of land, etc.)— <b>applicable</b> .	401 KAR 63:010 § 3(1) and (1)(a), (b), (d), (e) and (f)		✓	✓	✓	✓	✓	✓
	No person shall cause or permit the discharge of visible fugitive dust emissions beyond the lot line of the property on which the emissions originate.		401 KAR 63:010 § 3(2)		✓	✓	✓	✓	✓	✓
Activities causing radionuclide emissions	Emissions of radionuclides to the ambient air from DOE facilities shall not exceed those amounts that would cause any member of the public to receive in any year an EDE of 10 mrem/yr.	Radionuclide emissions from point sources at a DOE facility— <b>applicable</b> .	40 CFR § 61.92 401 KAR 57:002		✓	✓	✓	✓	✓	✓

**Table 4.2. Action-specific ARARs for the Oil Landfarm and the C-720 Northeast and Southeast Sites (Continued)**

Action	Requirement	Prerequisite	Citation	Alt 2	Alt 3	Alt 4	Alt 5	Alt 6	Alt 7	Alt 8
Activities causing toxic substances or potentially hazardous matter emissions	Persons responsible for a source from which hazardous matter or toxic substances may be emitted shall provide the utmost care and consideration in the handling of these materials to the potentially harmful effects of the emissions resulting from such activities. No owner or operator shall allow any affected facility to emit potentially hazardous matter or toxic substances in such quantities or duration as to be harmful to the health and welfare of humans, animals and plants.	Emissions of potentially hazardous matter or toxic substances as defined in 401 KAR 63:020 § 2 (2) — <b>applicable</b> .	401 KAR 63:020 § 3		✓	✓	✓	✓	✓	✓
Activities causing storm water runoff (e.g., clearing, grading, excavation)	Implement good construction techniques to control pollutants in storm water discharges during and after construction in accordance with substantive requirements provided by permits issued pursuant to 40 CFR § 122.26(c).	Storm water discharges associated with small construction activities as defined in 40 CFR § 122.26(b)(15) and 401 KAR 5:002 § 1 (157)— <b>applicable</b> .	40 CFR § 122.26(c)(1)(ii)(C) and (D) 401 KAR 5:060 § 8	✓	✓	✓	✓	✓	✓	✓
	Storm water runoff associated with construction activities taking place at a facility with an existing Best Management Practices (BMP) Plan shall be addressed under the facility BMP and not under a storm water general permit.	Storm water discharges associated with small construction activities as defined in 40 CFR § 122.26(b)(15) and 401 KAR 5:002 § 1 (157)— <b>TBC</b> .	Fact Sheet for the KPDES General Permit For Storm water Discharges Associated with Construction Activities, June 2009	✓	✓	✓	✓	✓	✓	✓
	Best management storm water controls will be implemented and may include, as appropriate, erosion and sedimentation control measures, structural practices (e.g., silt fences, straw bale barriers) and vegetative practices (e.g., seeding); storm water management (e.g., diversion); and maintenance of control measures in order to ensure compliance with the standards in Section C.5. Storm Water Discharge Quality.	Storm water runoff associated with construction activities taking place at a facility [PGDP] with an existing BMP Plan— <b>TBC</b> .	Appendix C of the PGDP Best Management Practices Plan (2007) — Examples of Storm water Controls	✓	✓	✓	✓	✓	✓	✓

**Table 4.2. Action-specific ARARs for the Oil Landfarm and the C-720 Northeast and Southeast Sites (Continued)**

Action	Requirement	Prerequisite	Citation	Alt 2	Alt 3	Alt 4	Alt 5	Alt 6	Alt 7	Alt 8
<i>Monitoring, Extraction, and Injection Well Installation and Abandonment</i>										
Monitoring well installation	Permanent monitoring wells shall be constructed, modified, and abandoned in such a manner as to prevent the introduction or migration of contamination to a water-bearing zone or aquifer through the casing, drill hole, or annular materials.	Construction of monitoring well as defined in 401 KAR 6:001 §1(18) for remedial action— <b>applicable</b> .	401 KAR 6:350 §1(2)	✓	✓	✓	✓	✓	✓	✓
	All permanent (including boreholes) shall be constructed to comply with the substantive requirements provided in the following Sections of 401 KAR 6:350: <ul style="list-style-type: none"> <li>• Section 2. Design Factors;</li> <li>• Section 3. Monitoring Well Construction;</li> <li>• Section 7. Materials for Monitoring Wells; and</li> <li>• Section 8. Surface Completion.</li> </ul>		401 KAR 6:350 § 2, 3, 7, and 8	✓	✓	✓	✓	✓	✓	✓
	If conditions exist or are believed to exist that preclude compliance with the requirements of 401 KAR 6:350, may request a variance prior to well construction or well abandonment.  <i>NOTE: Variance shall be made as part of the FFA CERCLA document review and approval process and shall include:</i> <ul style="list-style-type: none"> <li>• A justification for the variance; and</li> <li>• Proposed construction, modification, or abandonment procedures to be used in lieu of compliance with 401 KAR 6:350 and an explanation as to how the alternate well construction procedures ensure the protection of the quality of the groundwater and the protection of public health and safety.</li> </ul>		401 KAR 6:350 § 1(6)(a)(6) and (7)	✓	✓	✓	✓	✓	✓	✓



**Table 4.2. Action-specific ARARs for the Oil Landfarm and the C-720 Northeast and Southeast Sites (Continued)**

Action	Requirement	Prerequisite	Citation	Alt 2	Alt 3	Alt 4	Alt 5	Alt 6	Alt 7	Alt 8
Development of monitoring well	Newly installed wells shall be developed until the column of water in the well is free of visible sediment. This well-development protocol shall not be used as a method for purging prior to water quality sampling.	Construction of monitoring well as defined in 401 KAR 6:001 §1(18) for remedial action— <b>applicable.</b>	401 KAR 6:350 §9	✓	✓	✓	✓	✓	✓	✓
Direct Push monitoring well installation	Wells installed using direct push technology shall be constructed, modified, and abandoned in such a manner as to prevent the introduction or migration of contamination to a water-bearing zone or aquifer through the casing, drill hole, or annular materials.	Construction of direct push monitoring well as defined in 401 KAR 6:001 §1(18) for remedial action— <b>applicable.</b>	401 KAR 6:350 §5 (1)	✓	✓	✓	✓	✓	✓	✓
	Shall also comply with the following additional standards: (a) The outside diameter of the borehole shall be a minimum of 1 inch greater than the outside diameter of the well casing; (b) Premixed bentonite slurry or bentonite chips with a minimum of one-eighth (1/8) diameter shall be used in the sealed interval below the static water level; an (c) 1. Direct push wells shall not be constructed through more than one water-bearing formation unless the upper water bearing zone is isolated by temporary or permanent casing. 2. The direct push tool string may serve as the temporary casing.		401 KAR 6:350 §5 (3)	✓	✓	✓	✓	✓	✓	✓
Monitoring well abandonment	A monitoring well that has been damaged or is otherwise unsuitable for use as a monitoring well, shall be abandoned within 30 days from the last sampling date or 30 days from the date it is determined that the well is no longer suitable for its intended use.	Construction of monitoring well as defined in 401 KAR 6:001 §1(18) for remedial action— <b>applicable.</b>	401 KAR 6:350 §11 (1)	✓	✓	✓	✓	✓	✓	✓
	Wells shall be abandoned in such a manner as to prevent the migration of surface water or contaminants to the subsurface and to prevent migration of contaminants among water bearing zones.		401 KAR 6:350 §11 (1)(a)	✓	✓	✓	✓	✓	✓	✓

**Table 4.2. Action-specific ARARs for the Oil Landfarm and the C-720 Northeast and Southeast Sites (Continued)**

Action	Requirement	Prerequisite	Citation	Alt 2	Alt 3	Alt 4	Alt 5	Alt 6	Alt 7	Alt 8
	Abandonment methods and sealing materials for all types of monitoring wells provided in subparagraphs (a)-(b) and (d)-(e) shall be followed.		401 KAR 6:350 §11 (2)	✓	✓	✓	✓	✓	✓	✓
Extraction well installation	Wells shall be constructed, modified, and abandoned in such a manner as to prevent the introduction or migration of contamination to a water-bearing zone or aquifer through the casing, drill hole, or annular materials.	Construction of monitoring well for remedial action— <b>relevant and appropriate.</b>	401 KAR 6:350 §1 (2)				✓		✓	
Reinjection of treated contaminated groundwater, or, injection of bioamendments, surfactants, or reagents	No owner or operator shall construct, operate, maintain, convert, plug, abandon, or conduct any other injection activity in a manner that allows the movement of fluid containing any contaminant into underground sources of drinking water, if the presence of that contaminant may cause a violation of any primary drinking water regulation under 40 CFR Part 142 or may otherwise adversely affect the health of persons.	Underground injection into an underground source of drinking water— <b>relevant and appropriate.</b>	40 CFR § 144.12(a)		✓	✓	✓	✓	✓	✓
Reinjection of treated contaminated groundwater	Wells are not prohibited if injection is approved by EPA or a State pursuant to provisions for cleanup of releases under CERCLA or RCRA <i>as provided in the FFA CERCLA document.</i>	Class IV wells [as defined in 40 CFR § 144.6(d)] used to reinject treated contaminated groundwater into the same formation from which it was drawn— <b>relevant and appropriate.</b>	40 CFR § 144.13(c) RCRA § 3020(b)				✓		✓	✓
	Prior to abandonment any Class IV well, the owner or operator shall plug or otherwise close the well in a manner <i>as provided in the FFA CERCLA document.</i>	Class IV wells [as defined in 40 CFR § 144.6(d)] used to reinject of treated contaminated groundwater into the same formation from which it was drawn— <b>relevant and appropriate.</b>	40 CFR § 144.23(b)(1)				✓			

**Table 4.2. Action-specific ARARs for the Oil Landfarm and the C-720 Northeast and Southeast Sites (Continued)**

Action	Requirement	Prerequisite	Citation	Alt 2	Alt 3	Alt 4	Alt 5	Alt 6	Alt 7	Alt 8
Plugging and abandonment of Class IV injection wells	Prior to abandoning the well, the owner or operator shall close the well in accordance with 40 <i>CFR</i> § 144.23(b).	Operation of a Class IV injection well [as defined in 40 <i>CFR</i> § 144.6(d)] — <b>relevant and appropriate.</b>	40 <i>CFR</i> § 146.10(b)				✓		✓	✓
Injection of bioamendments, surfactants, or reagents	An injection activity cannot allow the movement of fluid containing any contaminant into USDWs, if the presence of that contaminant may cause a violation of the primary drinking water standards under 40 <i>CFR</i> part 141, other health based standards, or may otherwise adversely affect the health of persons. This prohibition applies to well construction, operation, maintenance, conversion, plugging, closure, or any other injection activity.	Class V wells [as defined in 40 <i>CFR</i> § 144.6(e)] used to inject bioamendments, surfactants, or reagents — <b>relevant and appropriate.</b>	40 <i>CFR</i> § 144.82(a)(1)		✓	✓		✓		
	Wells must be closed in a manner that complies with the above prohibition of fluid movement. Also, any soil, gravel, sludge, liquids, or other materials removed from or adjacent to the well must be disposed or otherwise managed in accordance with substantive applicable Federal, State, and local regulations and requirements.		40 <i>CFR</i> § 144.82(b)		✓	✓		✓	✓	✓
<b>General Waste Management</b>										
Management of PCB waste	Any person storing or disposing of PCB waste must do so in accordance with 40 <i>CFR</i> § 761, Subpart D.	Storage or disposal of waste containing PCBs at concentrations ≥ 50 ppm— <b>applicable.</b>	40 <i>CFR</i> § 761.50(a)	✓	✓	✓	✓	✓	✓	✓
	Any person cleaning up and disposing of PCBs shall do so based on the concentration at which the PCBs are found.	Cleanup and disposal of PCB remediation waste as defined in 40 <i>CFR</i> § 761.3— <b>applicable.</b>	40 <i>CFR</i> § 761.61	✓	✓	✓	✓	✓	✓	✓
Management of PCB/Radioactive waste	Any person storing such waste must do so taking into account both its PCB concentration and radioactive properties, except as provided in 40 <i>CFR</i> § 761.65(a)(1), (b)(1)(ii) and (c)(6)(i).	Generation of PCB/Radioactive waste with ≥ 50 ppm PCBs for storage— <b>applicable.</b>	40 <i>CFR</i> § 761.50(b)(7)(i)	✓	✓	✓	✓	✓	✓	✓

**Table 4.2. Action-specific ARARs for the Oil Landfarm and the C-720 Northeast and Southeast Sites (Continued)**

Action	Requirement	Prerequisite	Citation	Alt 2	Alt 3	Alt 4	Alt 5	Alt 6	Alt 7	Alt 8
	Any person disposing of such waste must do so taking into account both its PCB concentration and its radioactive properties. If, taking into account only the properties of the PCBs in the waste (and not the radioactive properties of the waste), the waste meets the requirements for disposal in a facility permitted, licensed, or registered by a state as a municipal or nonmunicipal nonhazardous waste landfill [e.g., PCB bulk-product waste under 40 <i>CFR</i> §761.62(b)(1)], then the person may dispose of PCB/radioactive waste, without regard to the PCBs, based on its radioactive properties in accordance with applicable requirements for the radioactive component of the waste.	Generation of PCB/radioactive waste with ≥50 ppm PCBs for disposal— <b>applicable</b> .	40 <i>CFR</i> § 761.50(b)(7)(ii)	✓	✓	✓	✓	✓	✓	✓
<b>Waste Characterization</b>										
Characterization of solid waste	Must determine if solid waste is excluded from regulation under 40 <i>CFR</i> § 261.4.	Generation of solid waste as defined in 40 <i>CFR</i> § 261.2— <b>applicable</b> .	40 <i>CFR</i> § 262.11(a) 401 <i>KAR</i> 32:010 §2	✓	✓	✓	✓	✓	✓	✓
	Must determine if waste is listed as a hazardous waste in subpart D of 40 <i>CFR</i> Part 261.	Generation of solid waste which is not excluded under 40 <i>CFR</i> § 261.4— <b>applicable</b> .	40 <i>CFR</i> § 262.11(b) 401 <i>KAR</i> 32:010 §2	✓	✓	✓	✓	✓	✓	✓
	Must determine whether the waste is characteristic waste (identified in subpart C of 40 <i>CFR</i> Part 261) by using prescribed testing methods or applying generator knowledge based on information regarding material or processes used.	Generation of solid waste that is not listed in subpart D of 40 <i>CFR</i> Part 261 and not excluded under 40 <i>CFR</i> § 261.4— <b>applicable</b> .	40 <i>CFR</i> § 262.11(c) 401 <i>KAR</i> 32:010 §2	✓	✓	✓	✓	✓	✓	✓
	Must refer to Parts 261, 262, 264, 265, 266, 268, and 273 of Chapter 40 for possible exclusions or restrictions pertaining to management of the specific waste.	Generation of solid waste which is determined to be hazardous waste— <b>applicable</b> .	40 <i>CFR</i> § 262.11(d) 401 <i>KAR</i> 32:010 §2	✓	✓	✓	✓	✓	✓	✓

**Table 4.2. Action-specific ARARs for the Oil Landfarm and the C-720 Northeast and Southeast Sites (Continued)**

Action	Requirement	Prerequisite	Citation	Alt 2	Alt 3	Alt 4	Alt 5	Alt 6	Alt 7	Alt 8
Characterization of hazardous waste	Must obtain a detailed chemical and physical analysis on a representative sample of the waste(s), which at a minimum contains all the information that must be known to treat, store, or dispose of the waste in accordance with pertinent sections of 40 <i>CFR</i> §§ 264 and 268.	Generation of RCRA-hazardous waste for storage, treatment or disposal— <b>applicable</b> .	40 <i>CFR</i> § 264.13(a)(1) 401 <i>KAR</i> 34:020 § 4	✓	✓	✓	✓	✓	✓	✓
Characterization of industrial wastewater	Industrial wastewater discharges that are point source discharges subject to regulation under section 402 of the Clean Water Act, as amended, are not solid wastes for the purpose of hazardous waste management. [Comment: This exclusion applies only to the actual point source discharge. It does not exclude industrial wastewaters while they are being collected, stored or treated before discharge, nor does it exclude sludges that are generated by industrial wastewater treatment.] NOTE: For purpose of this exclusion, the CERCLA on-site treatment system for extracted VOCs and groundwater will be considered equivalent to a wastewater treatment unit and the point source discharges subject to regulation under CWA Section 402, provided the effluent meets all identified CWA ARARs.	Generation of industrial wastewater for treatment and discharge into surface water— <b>applicable</b> .	40 <i>CFR</i> § 261.4(a)(2) 401 <i>KAR</i> 31:010 § 4				✓		✓	
Determinations for management of hazardous waste	Must determine each EPA Hazardous Waste Number (Waste Code) to determine the applicable treatment standards under 40 <i>CFR</i> § 268.40 <i>et. seq.</i> <i>Note:</i> This determination may be made concurrently with the hazardous waste determination required in 40 <i>CFR</i> § 262.11.	Generation of hazardous waste— <b>applicable</b> .	40 <i>CFR</i> § 268.9(a) 401 <i>KAR</i> 37:010 §8	✓	✓	✓	✓	✓	✓	✓

**Table 4.2. Action-specific ARARs for the Oil Landfarm and the C-720 Northeast and Southeast Sites (Continued)**

Action	Requirement	Prerequisite	Citation	Alt 2	Alt 3	Alt 4	Alt 5	Alt 6	Alt 7	Alt 8
	Must determine the underlying hazardous constituents [as defined in 40 <i>CFR</i> § 268.2(i)] in the characteristic waste.	Generation of RCRA characteristic hazardous waste (and is not D001 non-wastewaters treated by CMBST, RORGS, or POLYM of Section 268.42 Table 1) for storage, treatment or disposal— <b>applicable</b> .	40 <i>CFR</i> § 268.9(a) 401 <i>KAR</i> 37:010 §8	✓	✓	✓	✓	✓	✓	✓
	Must determine if the hazardous waste meets the treatment standards in 40 <i>CFR</i> §§ 268.40, 268.45, or 268.49 by testing in accordance with prescribed methods or use of generator knowledge of waste. <i>Note:</i> This determination can be made concurrently with the hazardous waste determination required in 40 <i>CFR</i> § 262.11.	Generation of hazardous waste— <b>applicable</b> .	40 <i>CFR</i> § 268.7(a) 401 <i>KAR</i> 37:010 §7	✓	✓	✓	✓	✓	✓	✓
Characterization of LLW	Shall be characterized using direct or indirect methods and the characterization documented in sufficient detail to ensure safe management and compliance with the WAC of the receiving facility.	Generation of LLW for storage and disposal at a DOE facility— <b>TBC</b> .	DOE M 435.1-1(IV)(I)	✓	✓	✓	✓	✓	✓	✓
	Characterization data shall, at a minimum, include the following information relevant to the management of the waste:		DOE M 435.1-1(IV)(I)(2)	✓	✓	✓	✓	✓	✓	✓
	• physical and chemical characteristics;		DOE M 435.1-1(IV)(I)(2)(a)	✓	✓	✓	✓	✓	✓	✓
	• volume, including the waste and any stabilization or absorbent media;		DOE M 435.1-1(IV)(I)(2)(b)	✓	✓	✓	✓	✓	✓	✓
	• weight of the container and contents;		DOE M 435.1-1(IV)(I)(2)(c)	✓	✓	✓	✓	✓	✓	✓
	• identities, activities, and concentration of major radionuclides;		DOE M 435.1-1(IV)(I)(2)(d)	✓	✓	✓	✓	✓	✓	✓
	• characterization date;		DOE M 435.1-1(IV)(I)(2)(e)	✓	✓	✓	✓	✓	✓	✓

**Table 4.2. Action-specific ARARs for the Oil Landfarm and the C-720 Northeast and Southeast Sites (Continued)**

Action	Requirement	Prerequisite	Citation	Alt 2	Alt 3	Alt 4	Alt 5	Alt 6	Alt 7	Alt 8
<i>Waste Storage</i>										
	<ul style="list-style-type: none"> <li>generating source; and</li> </ul>		DOE M 435.1-1(IV)(I)(2)(f)	✓	✓	✓	✓	✓	✓	✓
	<ul style="list-style-type: none"> <li>any other information that may be needed to prepare and maintain the disposal facility performance assessment, or demonstrate compliance with performance objectives.</li> </ul>		DOE M 435.1-1(IV)(I)(2)(g)	✓	✓	✓	✓	✓	✓	✓
Temporary on-site storage of hazardous waste in containers	A generator may accumulate hazardous waste at the facility provided that	Accumulation of RCRA hazardous waste on-site as defined in 40 <i>CFR</i> § 260.10— <b>applicable.</b>	40 <i>CFR</i> § 262.34(a) 401 <i>KAR</i> 32:030 §5	✓	✓	✓	✓	✓	✓	✓
	<ul style="list-style-type: none"> <li>waste is placed in containers that comply with 40 <i>CFR</i> § 265.171-173;</li> </ul>		40 <i>CFR</i> § 262.34(a)(1)(i) 401 <i>KAR</i> 32:030 §5	✓	✓	✓	✓	✓	✓	✓
	<ul style="list-style-type: none"> <li>the date upon which accumulation begins is clearly marked and visible for inspection on each container;</li> </ul>		40 <i>CFR</i> § 262.34(a)(2) 401 <i>KAR</i> 32:030 §5	✓	✓	✓	✓	✓	✓	✓
	<ul style="list-style-type: none"> <li>container is marked with the words “hazardous waste.”</li> </ul>		40 <i>CFR</i> § 262.34(a)(3) 401 <i>KAR</i> 32:030 § 5	✓	✓	✓	✓	✓	✓	✓
	Container may be marked with other words that identify the contents.	Accumulation of 55 gal or less of RCRA hazardous waste or one quart of acutely hazardous waste listed in 261.33(e) at or near any point of generation— <b>applicable.</b>	40 <i>CFR</i> § 262.34(c)(1) 401 <i>KAR</i> 32:030 §5	✓	✓	✓	✓	✓	✓	✓

**Table 4.2. Action-specific ARARs for the Oil Landfarm and the C-720 Northeast and Southeast Sites (Continued)**

Action	Requirement	Prerequisite	Citation	Alt 2	Alt 3	Alt 4	Alt 5	Alt 6	Alt 7	Alt 8
Use and management of containers holding hazardous waste	If container is not in good condition or if it begins to leak, must transfer waste into container in good condition.	Storage of RCRA hazardous waste in containers— <b>applicable</b> .	40 <i>CFR</i> § 265.171 401 <i>KAR</i> 35:180 §2	✓	✓	✓	✓	✓	✓	✓
	Use container made or lined with materials compatible with waste to be stored so that the ability of the container is not impaired.		40 <i>CFR</i> § 265.172 401 <i>KAR</i> 35:180 §3	✓	✓	✓	✓	✓	✓	✓
	Keep containers closed during storage, except to add/remove waste.		40 <i>CFR</i> § 265.173(a) 401 <i>KAR</i> 35:180 §4	✓	✓	✓	✓	✓	✓	✓
	Open, handle and store containers in a manner that will not cause containers to rupture or leak.		40 <i>CFR</i> § 265.173(b) 401 <i>KAR</i> 35:180 §4	✓	✓	✓	✓	✓	✓	✓
Storage of hazardous waste in container area	Area must have a containment system designed and operated in accordance with 40 <i>CFR</i> § 264.175(b).	Storage of RCRA hazardous waste in containers with free liquids— <b>applicable</b> .	40 <i>CFR</i> § 264.175(a)	✓	✓	✓	✓	✓	✓	✓
	Area must be sloped or otherwise designed and operated to drain liquid from precipitation, or Containers must be elevated or otherwise protected from contact with accumulated liquid.	Storage of RCRA-hazardous waste in containers that do not contain free liquids (other than F020, F021, F022, F023, F026 and F027)— <b>applicable</b> .	40 <i>CFR</i> § 264.175(c)	✓	✓	✓	✓	✓	✓	✓
Storage of PCB waste and/or PCB/radioactive waste in a RCRA-regulated container storage area	Does not have to meet storage unit requirements in 40 <i>CFR</i> § 761.65(b)(1) provided unit	Storage of PCBs and PCB Items at concentrations ≥ 50ppm designated for disposal— <b>applicable</b> .	40 <i>CFR</i> § 761.65(b)(2)	✓	✓	✓	✓	✓	✓	✓



**Table 4.2. Action-specific ARARs for the Oil Landfarm and the C-720 Northeast and Southeast Sites (Continued)**

Action	Requirement	Prerequisite	Citation	Alt 2	Alt 3	Alt 4	Alt 5	Alt 6	Alt 7	Alt 8
	<ul style="list-style-type: none"> <li>is permitted by EPA under RCRA § 3004 to manage hazardous waste in containers and spills of PCBs cleaned up in accordance with Subpart G of 40 <i>CFR</i> § 761; or</li> </ul>		40 <i>CFR</i> § 761.65(b)(2)(i)	✓	✓	✓	✓	✓	✓	✓
	<ul style="list-style-type: none"> <li>qualifies for interim status under RCRA § 3005 to manage hazardous waste in containers and spills of PCBs cleaned up in accordance with Subpart G of 40 <i>CFR</i> § 761; or</li> </ul>		40 <i>CFR</i> § 761.65(b)(2)(ii)	✓	✓	✓	✓	✓	✓	✓
	<ul style="list-style-type: none"> <li>is permitted by an authorized state under RCRA § 3006 to manage hazardous waste in containers and spills of PCBs cleaned up in accordance with Subpart G of 40 <i>CFR</i> § 761.</li> </ul>		40 <i>CFR</i> § 761.65(b)(2)(iii)	✓	✓	✓	✓	✓	✓	✓
	NOTE: For purpose of this exclusion, CERCLA remediation waste, which is also considered PCB waste, can be stored on-site provided the area meets all of the identified RCRA container storage ARARs and spills of PCBs cleaned up in accordance with Subpart G of 40 <i>CFR</i> § 761.									
Storage of PCB waste and/or PCB/radioactive waste in non-RCRA regulated unit	Except as provided in 40 <i>CFR</i> § 761.65 (b)(2), (c)(1), (c)(7), (c)(9), and (c)(10), after July 1, 1978, owners or operators of any facilities used for the storage of PCBs and PCB Items designated for disposal shall comply with the storage unit requirements in 40 <i>CFR</i> § 761.65(b)(1).	Storage of PCBs and PCB Items at concentrations ≥ 50ppm designated for disposal— <b>applicable</b> .	40 <i>CFR</i> § 761.65(b)	✓	✓	✓	✓	✓	✓	✓
	Storage facility shall meet the following criteria: <ul style="list-style-type: none"> <li>Adequate roof and walls to prevent rainwater from reaching stored PCBs and PCB items;</li> </ul>		40 <i>CFR</i> § 761.65(b)(1) 40 <i>CFR</i> § 761.65(b)(1)(i)	✓	✓	✓	✓	✓	✓	✓

**Table 4.2. Action-specific ARARs for the Oil Landfarm and the C-720 Northeast and Southeast Sites (Continued)**

Action	Requirement	Prerequisite	Citation	Alt 2	Alt 3	Alt 4	Alt 5	Alt 6	Alt 7	Alt 8
	<ul style="list-style-type: none"> <li>Adequate floor that has continuous curbing with a minimum 6-inch high curb. Floor and curb must provide a containment volume equal to at least two times the internal volume of the largest PCB article or container or 25% of the internal volume of all articles or containers stored there, whichever is greater. <i>Note:</i> 6 inch minimum curbing not required for area storing PCB/radioactive waste;</li> </ul>		40 <i>CFR</i> § 761.65(b)(1)(ii)	✓	✓	✓	✓	✓	✓	✓
	<ul style="list-style-type: none"> <li>No drain valves, floor drains, expansion joints, sewer lines, or other openings that would permit liquids to flow from curbed area;</li> </ul>		40 <i>CFR</i> § 761.65(b)(1)(iii)	✓	✓	✓	✓	✓	✓	✓
	<ul style="list-style-type: none"> <li>Floors and curbing constructed of Portland cement, concrete, or a continuous, smooth, non-porous surface that prevents or minimizes penetration of PCBs; and</li> </ul>		40 <i>CFR</i> § 761.65(b)(1)(iv)	✓	✓	✓	✓	✓	✓	✓
	<ul style="list-style-type: none"> <li>Not located at a site that is below the 100-year flood water elevation.</li> </ul>		40 <i>CFR</i> § 761.65(b)(1)(v)	✓	✓	✓	✓	✓	✓	✓
	Storage area must be properly marked as required by 40 <i>CFR</i> § 761.40(a)(10).		40 <i>CFR</i> § 761.65(c)(3)	✓	✓	✓	✓	✓	✓	✓
Risk-based storage of PCB remediation waste	<p>May store PCB remediation waste in a manner other than prescribed in 40 <i>CFR</i> § 761.65(b) if approved in writing from EPA provided the method will not pose an unreasonable risk of injury to human health or the environment.</p> <p><i>NOTE:</i> EPA approval of alternative storage method will be obtained by approval of the FFA CERCLA document.</p>	Storage of waste containing PCBs in a manner other than prescribed in 40 <i>CFR</i> § 761.65(b) (see above) — <b>applicable</b> .	40 <i>CFR</i> § 761.61(c)	✓	✓	✓	✓	✓	✓	✓
Temporary storage of PCB waste (e.g., PPE, rags) in a container(s)	Container(s) shall be marked as illustrated in 40 <i>CFR</i> § 761.45(a).	Storage of PCBs and PCB items at concentrations ≥ 50ppm in containers for disposal— <b>applicable</b> .	40 <i>CFR</i> § 761.40(a)(1)	✓	✓	✓	✓	✓	✓	✓

**Table 4.2. Action-specific ARARs for the Oil Landfarm and the C-720 Northeast and Southeast Sites (Continued)**

Action	Requirement	Prerequisite	Citation	Alt 2	Alt 3	Alt 4	Alt 5	Alt 6	Alt 7	Alt 8
	Storage area must be properly marked as required by 40 <i>CFR</i> § 761.40(a)(10).		40 <i>CFR</i> § 761.65(c)(3)	✓	✓	✓	✓	✓	✓	✓
	Any leaking PCB Items and their contents shall be transferred immediately to a properly marked nonleaking container(s).		40 <i>CFR</i> § 761.65(c)(5)	✓	✓	✓	✓	✓	✓	✓
	Except as provided in 40 <i>CFR</i> § 761.65(c)(6)(i) and (c)(6)(ii), container(s) shall be in accordance with requirements set forth in DOT HMR at 49 <i>CFR</i> §§ 171-180.		40 <i>CFR</i> § 761.65(c)(6)	✓	✓	✓	✓	✓	✓	✓
Staging of LLW	Shall be for the purpose of the accumulation of such quantities of wastes necessary to facilitate transportation, treatment, and disposal.	Staging of LLW at a DOE facility— <b>TBC</b> .	DOE M 435.1-1 (IV)(N)(7)	✓	✓	✓	✓	✓	✓	✓
Temporary storage of LLW	Shall not be readily capable of detonation, explosive decomposition, reaction at anticipated pressures and temperatures, or explosive reaction with water.	Temporary storage of LLW at a DOE facility— <b>TBC</b> .	DOE M 435.1-1 (IV)(N)(1)	✓	✓	✓	✓	✓	✓	✓
	Shall be stored in a location and manner that protects the integrity of waste for the expected time of storage.		DOE M 435.1-1 (IV)(N)(3)	✓	✓	✓	✓	✓	✓	✓
	Shall be managed to identify and segregate LLW from mixed waste.		DOE M 435.1-1 (IV)(N)(6)	✓	✓	✓	✓	✓	✓	✓
Packaging of LLW for storage	Shall be packaged in a manner that provides containment and protection for the duration of the anticipated storage period and until disposal is achieved or until the waste has been removed from the container.	Storage of LLW in containers at a DOE facility — <b>TBC</b> .	DOE M 435.1-1(IV)(L)(1)(a)	✓	✓	✓	✓	✓	✓	✓
	Vents or other measures shall be provided if the potential exists for pressurizing or generating flammable or explosive concentrations of gases within the waste container.		DOE M 435.1-1(IV)(L)(1)(b)	✓	✓	✓	✓	✓	✓	✓
	Containers shall be marked such that their contents can be identified.		DOE M 435.1-1(IV)(L)(1)(c)	✓	✓	✓	✓	✓	✓	✓

**Table 4.2. Action-specific ARARs for the Oil Landfarm and the C-720 Northeast and Southeast Sites (Continued)**

Action	Requirement	Prerequisite	Citation	Alt 2	Alt 3	Alt 4	Alt 5	Alt 6	Alt 7	Alt 8
Packaging of LLW for off-site disposal	Waste shall not be packaged for disposal in a cardboard or fiberboard box.	Packaging of LLW for off-site shipment of LLW to a commercial NRC or Agreement State licensed disposal facility— <b>relevant and appropriate.</b>	10 <i>CFR</i> § 61.56 902 <i>KAR</i> 100:021 § 7 (1)(b)	✓	✓	✓	✓	✓	✓	✓
	Liquid waste shall be solidified or packaged in sufficient absorbent material to absorb twice the volume of the liquid.	Preparation of liquid LLW for off-site shipment of LLW to a commercial NRC or Agreement State licensed disposal facility— <b>relevant and appropriate.</b>	10 <i>CFR</i> § 61.56 902 <i>KAR</i> 100:021 § 7 (1)(c)	✓	✓	✓	✓	✓	✓	✓
	Solid waste containing liquid shall contain as little freestanding and noncorrosive liquid as is reasonably achievable. The liquid shall not exceed one (1) percent of the volume.	Preparation of solid LLW containing liquid for off-site shipment of LLW to a commercial NRC or Agreement State licensed disposal facility— <b>relevant and appropriate.</b>	10 <i>CFR</i> § 61.56 902 <i>KAR</i> 100:021 § 7 (1)(d)	✓	✓	✓	✓	✓	✓	✓
	Waste shall not be readily capable of <ul style="list-style-type: none"> <li>• Detonation;</li> <li>• Explosive decomposition or reaction at normal pressures and temperatures; or</li> <li>• Explosive reaction with water.</li> </ul>	Packaging of LLW for off-site shipment of LLW to a commercial NRC or Agreement State licensed disposal facility— <b>relevant and appropriate.</b>	10 <i>CFR</i> § 61.56 902 <i>KAR</i> 100:021 § 7 (1)(e)	✓	✓	✓	✓	✓	✓	✓

**Table 4.2. Action-specific ARARs for the Oil Landfarm and the C-720 Northeast and Southeast Sites (Continued)**

Action	Requirement	Prerequisite	Citation	Alt 2	Alt 3	Alt 4	Alt 5	Alt 6	Alt 7	Alt 8
	Waste shall not contain, or be capable of generating, quantities of toxic gases, vapors, or fumes harmful to a person transporting, handling, or disposing of the waste.	Packaging of LLW for off-site shipment of LLW to a commercial NRC or Agreement State licensed disposal facility— <b>relevant and appropriate.</b>	10 <i>CFR</i> § 61.56 902 <i>KAR</i> 100:021 § 7 (1)(f)	✓	✓	✓	✓	✓	✓	✓
	Waste shall not be pyrophoric.	Packaging of pyrophoric LLW for off-site shipment of LLW to a commercial NRC or Agreement State licensed disposal facility— <b>relevant and appropriate.</b>	10 <i>CFR</i> § 61.56 902 <i>KAR</i> 100:021 § 7 (1)(g)	✓	✓	✓	✓	✓	✓	✓
Labeling of LLW packages	Each package of waste shall be clearly labeled to identify if it is Class A, Class B, or Class C waste, in accordance with 10 <i>CFR</i> § 61.55 or Agreement State waste classification requirements.	Preparation for off-site shipment of LLW to a commercial NRC or Agreement State licensed disposal facility— <b>relevant and appropriate.</b>	10 <i>CFR</i> § 61.57 902 <i>KAR</i> 100:021 § 8	✓	✓	✓	✓	✓	✓	✓
<b>Waste treatment and disposal</b>										
Transport or conveyance of collected RCRA wastewater to a WWTU located on the facility	Any dedicated tank systems, conveyance systems, and ancillary equipment used to treat, store or convey wastewater to an on-site KPDES-permitted wastewater treatment facility are exempt from the requirements of RCRA Subtitle C standards. <i>NOTE:</i> For purposes of this exclusion, any dedicated tank systems, conveyance systems, and ancillary equipment used to treat, store or convey CERCLA remediation wastewater to a CERCLA on-site wastewater treatment unit that meets all of the identified CWA ARARs for point source discharges from such a facility, are exempt from the requirements of RCRA Subtitle C standards.	On-site wastewater treatment units (as defined in 40 <i>CFR</i> § 260.10) subject to regulation under § 402 or § 307(b) of the CWA (i.e., KPDES-permitted) that manages hazardous wastewaters— <b>applicable.</b>	40 <i>CFR</i> § 264.1(g)(6) 401 <i>KAR</i> 34:010 § 1				✓		✓	

**Table 4.2. Action-specific ARARs for the Oil Landfarm and the C-720 Northeast and Southeast Sites (Continued)**

Action	Requirement	Prerequisite	Citation	Alt 2	Alt 3	Alt 4	Alt 5	Alt 6	Alt 7	Alt 8
Release of property with residual radioactive material to an off-site commercial facility	Prior to being released, property shall be surveyed to determine whether both removable and total surface contamination (including contamination present on and under any coating) are in compliance with the levels given in Figure IV-1 of DOE O 5400.5 and the contamination has been subjected to the ALARA process.	Generation of DOE materials and equipment with surface residual radioactive contamination— <b>TBC</b> .	DOE O 5400.5 (II)(5)(c)(1) and 5400.5(IV)(4)(d)	✓	✓	✓	✓	✓	✓	✓
	Material that has been radioactively contaminated in depth may be released if criteria and survey techniques are approved by DOE EH-1.	Generation of DOE materials and equipment that are volumetrically contaminated with radionuclides — <b>TBC</b> .	DOE O 5400.5 (II)(5)(c)(6)	✓	✓	✓	✓	✓	✓	✓
<i>Discharge of Wastewater from Groundwater Treatment System</i>										
General duty to mitigate for discharge of wastewater from groundwater treatment system	Take all reasonable steps to minimize or prevent any discharge or sludge use or disposal in violation of effluent standards which has a reasonable likelihood of adversely affecting human health or the environment.	Discharge of pollutants to surface waters— <b>applicable</b> .	401 KAR 5:065 § 2(1) and 40 CFR §122.41(d)				✓		✓	
Operation and maintenance of treatment system	Properly operate and maintain all facilities and systems of treatment and control (and related appurtenances) which are installed or used to achieve compliance with the effluent standards. Proper operation and maintenance also includes adequate laboratory controls and appropriate quality assurance procedures.	Discharge of pollutants to surface waters— <b>applicable</b> .	401 KAR 5:065 § 2(1) and 40 CFR § 122.41(e)				✓		✓	
Criteria for discharge of wastewater with radionuclides into surface water	To prevent the buildup of radionuclide concentrations in sediments, liquid process waste streams containing radioactive material in the form of settleable solids may be released to natural waterways if the concentration of radioactive material in the solids present in the waste stream does not exceed 5 pCi (0.2 Bq) per gram above background level, of settleable solids for alpha-emitting radionuclides or 50 pCi (2 Bq) per gram above background level, of settleable solids for beta gamma- emitting radionuclides.	Discharge of radioactive concentrations in sediments to surface water from a DOE facility— <b>TBC</b> .	DOE O 5400.5 II(3)(a)(4)				✓		✓	

**Table 4.2. Action-specific ARARs for the Oil Landfarm and the C-720 Northeast and Southeast Sites (Continued)**

Action	Requirement	Prerequisite	Citation	Alt 2	Alt 3	Alt 4	Alt 5	Alt 6	Alt 7	Alt 8
	To protect native animal aquatic organisms, the absorbed dose to these organisms shall not exceed 1 rad per day from exposure to the radioactive material in liquid wastes discharged to natural waterways.		DOE O 5400.5 II(3)(a)(5)				✓		✓	
Technology-based treatment requirements for wastewater discharge	To the extent that EPA promulgated effluent limitations are inapplicable, shall develop on a case-by-case Best Professional Judgment (BPJ) basis under § 402(a)(1)(B) of the CWA, technology based effluent limitations by applying the factors listed in 40 <i>CFR</i> §125.3(d) and shall consider: <ul style="list-style-type: none"> <li>The appropriate technology for this category or class of point sources, based upon all available information; and</li> <li>Any unique factors relating to the discharger.</li> </ul>	Discharge of pollutants to surface waters from other than a POTW— <b>applicable.</b>	40 <i>CFR</i> §125.3(c)(2)				✓		✓	
Water quality-based effluent limits for wastewater discharge	Must develop water quality based effluent limits that ensure that: <ul style="list-style-type: none"> <li>The level of water quality to be achieved by limits on point source(s) established under this paragraph is derived from, and complies with all applicable water quality standards; and</li> <li>Effluent limits developed to protect narrative or numeric water quality criteria are consistent with the assumptions and any available waste load allocation for the discharge prepared by the State and approved by EPA pursuant to 40 <i>CFR</i> §130.7.</li> </ul>	Discharge of pollutants to surface waters that causes, or has reasonable potential to cause, or contributes to an instream excursion above a narrative or numeric criteria within a State water quality standard established under § 303 of the CWA— <b>applicable.</b>	40 <i>CFR</i> §122.44(d)(1)(vi i)				✓		✓	
	Must attain or maintain a specified water quality through water quality related effluent limits established under § 302 of the CWA.	Discharge of pollutants to surface waters that causes, or has reasonable potential to cause, or contributes to an instream excursion above a narrative or numeric criteria within a State water quality standard— <b>applicable.</b>	40 <i>CFR</i> §122.44(d)(2)				✓		✓	

**Table 4.2. Action-specific ARARs for the Oil Landfarm and the C-720 Northeast and Southeast Sites (Continued)**

Action	Requirement	Prerequisite	Citation	Alt 2	Alt 3	Alt 4	Alt 5	Alt 6	Alt 7	Alt 8
	The numeric water quality criteria for fish consumption specified in Table 1 of 401 <i>KAR</i> 10:031 Section 6(1) provides allowable instream concentrations of pollutants that may be found in surface waters or discharged into surface waters.		401 <i>KAR</i> 10:031 § 6(1)				✓		✓	
Monitoring requirements for groundwater treatment system discharges	In addition to 40 <i>CFR</i> §122.48(a) and (b) and to assure compliance with effluent limitations, one must monitor, as provided in subsections (i) thru (iv) of 122.44(i)(1). <i>NOTE:</i> Monitoring parameters, including frequency of sampling, will be developed as part of the CERCLA process and included in a Remedial Design, RAWP, or other appropriate FFA CERCLA document.	Discharge of pollutants to surface waters— <b>applicable.</b>	40 <i>CFR</i> §122.44(i)(1) 401 <i>KAR</i> § 5:065 2(4)				✓		✓	
	All effluent limitations, standards and prohibitions shall be established for each outfall or discharge point, except as provided under § 122.44(k)		40 <i>CFR</i> §122.45(a) 401 <i>KAR</i> § 5:065 2(5)				✓		✓	
	All effluent limitations, standards and prohibitions, including those necessary to achieve water quality standards, shall unless impracticable be stated as: <ul style="list-style-type: none"> <li>Maximum daily and average monthly discharge limitations for all discharges.</li> </ul>	Continuous discharge of pollutants to surface waters— <b>applicable.</b>	40 <i>CFR</i> §122.45(d)(1) 401 <i>KAR</i> § 5:065 2(5)				✓		✓	
Effluent limits for radionuclides in wastewater	Shall not exceed the limits for radionuclides listed on Table II – Effluent Limitations.	Discharge of wastewater with radionuclides from an NRC Agreement State licensed facility into surface waters— <b>relevant and appropriate.</b>	902 <i>KAR</i> 100:019 § 44 (7)(a)				✓		✓	



**Table 4.2. Action-specific ARARs for the Oil Landfarm and the C-720 Northeast and Southeast Sites (Continued)**

Action	Requirement	Prerequisite	Citation	Alt 2	Alt 3	Alt 4	Alt 5	Alt 6	Alt 7	Alt 8
<i>Treatment of VOC Contaminated Groundwater</i>										
General standards for process vents used in treatment of VOC contaminated groundwater	<p>Select and meet the requirements under one of the options specified below:</p> <ul style="list-style-type: none"> <li>Control HAP emissions from the affected process vents according to the applicable standards specified in §§ 63.7890 through 63.7893.</li> <li>Determine for the remediation material treated or managed by the process vented through the affected process vents that the average total volatile organic hazardous air pollutant (VOHAP) concentration, as defined in § 63.7957, of this material is less than 10 (ppmw). Determination of VOHAP concentration will be made using procedures specified in § 63.7943.</li> <li>Control HAP emissions from affected process vents subject to another subpart under 40 <i>CFR</i> part 61 or 40 <i>CFR</i> part 63 in compliance with the standards specified in the applicable subpart.</li> </ul>	Process vents as defined in 40 <i>CFR</i> § 63.7957 used in site remediation of media (e.g., soil and groundwater) that could emit hazardous air pollutants (HAP) listed in Table 1 of Subpart GGGGG of Part 63 and vent stream flow exceeds the rate in 40 <i>CFR</i> §63.7885(c)(1)— <b>relevant and appropriate.</b>	40 <i>CFR</i> § 63:7885(b) 401 <i>KAR</i> 63:002, §§ 1 and 2, except for 40 <i>CFR</i> § 63.72 as incorporated in § 2(3)				✓		✓	

**Table 4.2. Action-specific ARARs for the Oil Landfarm and the C-720 Northeast and Southeast Sites (Continued)**

Action	Requirement	Prerequisite	Citation	Alt 2	Alt 3	Alt 4	Alt 5	Alt 6	Alt 7	Alt 8
Emission limitations for process vents used in treatment of VOC contaminated groundwater	<p>Meet the requirements under one of the options specified below:</p> <ul style="list-style-type: none"> <li>Reduce from all affected process vents the total emissions of the HAP to a level less than 1.4 kilograms per hour (kg/hr) and 2.8 Mg/yr (3.0 pounds per hour (lb/hr) and 3.1 tpy); or</li> <li>Reduce from all affected process vents the emissions of total organic compounds (TOC) (minus methane and ethane) to a level below 1.4 kg/hr and 2.8 Mg/yr (3.0 lb/hr and 3.1 tpy); or</li> <li>Reduce from all affected process vents the total emissions of the HAP by 95 percent by weight or more; or</li> <li>Reduce from all affected process vents the emissions of TOC (minus methane and ethane) by 95 percent by weight or more.</li> </ul> <p><i>NOTE: These emission limits are for the remediation activities conducted at the PGDP by the DOE.</i></p>	Process vents as defined in 40 <i>CFR</i> § 63.7957 used in site remediation of media (e.g., soil and groundwater) that could emit hazardous air pollutants (HAP) listed in Table 1 of Subpart GGGGG of Part 63 and vent stream flow exceeds the rate in 40 <i>CFR</i> § 63.7885(c)(1)— <b>relevant and appropriate.</b>	40 <i>CFR</i> § 63.7890(b)(1)-(4) 401 <i>KAR</i> 63:002, §§ 1 and 2, except for 40 <i>CFR</i> § 63.72 as incorporated in § 2(3)				✓		✓	
Standards for closed vent systems and control devices used in treatment of VOC contaminated groundwater	<p>For each closed vent system and control device you use to comply with the requirements above, you must meet the operating limit requirements and work practice standards in Sec. 63.7925(d) through (j) that apply to the closed vent system and control device.</p> <p><i>NOTE: EPA approval to use alternate work practices under paragraph (j) in 40 <i>CFR</i> 63.7925 will be obtained in FFA CERCLA document (e.g., Remedial Design).</i></p>	Closed vent system and control devices as defined in 40 <i>CFR</i> § 63.7957 that are used to comply with § 63.7890(b)— <b>relevant and appropriate.</b>	40 <i>CFR</i> § 63.7890(c)				✓		✓	
Monitoring of closed vent systems and control devices used in treatment of VOC contaminated groundwater	<p>Must monitor and inspect the closed vent system and control device according to the requirements in 40 <i>CFR</i> § 63.7927 that apply to the affected source.</p> <p><i>NOTE: Monitoring program will be developed as part of the CERCLA process and included in a Remedial Design or other appropriate FFA CERCLA document.</i></p>	Closed vent system and control devices as defined in 40 <i>CFR</i> § 63.7957 that are used to comply with § 63.7890(b)— <b>relevant and appropriate.</b>	40 <i>CFR</i> § 63.7892				✓		✓	

**Table 4.2. Action-specific ARARs for the Oil Landfarm and the C-720 Northeast and Southeast Sites (Continued)**

Action	Requirement	Prerequisite	Citation	Alt 2	Alt 3	Alt 4	Alt 5	Alt 6	Alt 7	Alt 8
Treatment of LLW	Treatment to provide more stable waste forms and to improve the long-term performance of a LLW disposal facility shall be implemented as necessary to meet the performance objectives of the disposal facility.	Treatment of LLW for disposal at a LLW disposal facility— <b>TBC</b> .	DOE M 435.1-1(IV)(O)	✓	✓	✓	✓	✓	✓	✓
Disposal of prohibited RCRA hazardous waste in a land-based unit	May be land disposed if it meets the requirements in the table “Treatment Standards for Hazardous Waste” at 40 <i>CFR</i> § 268.40 before land disposal.	Land disposal, as defined in 40 <i>CFR</i> § 268.2, of prohibited RCRA waste— <b>applicable</b> .	40 <i>CFR</i> § 268.40(a) 401 <i>KAR</i> 37:040 §2	✓	✓	✓	✓	✓	✓	✓
	All underlying hazardous constituents [as defined in 40 <i>CFR</i> § 268.2(i)] must meet the Universal Treatment Standards, found in 40 <i>CFR</i> § 268.48 Table UTS prior to land disposal.	Land disposal of restricted RCRA characteristic wastes (D001-D043) that are not managed in a wastewater treatment system that is regulated under the CWA, that is CWA equivalent, or that is injected into a Class I nonhazardous injection well— <b>applicable</b> .	40 <i>CFR</i> § 268.40(e) 401 <i>KAR</i> 37:040 § 2	✓	✓	✓	✓	✓	✓	✓
	Must be treated according to the alternative treatment standards of 40 <i>CFR</i> § 268.49(c) <u>or</u> according to the UTSs specified in 40 <i>CFR</i> § 268.48 applicable to the listed and/or characteristic waste contaminating the soil prior to land disposal.	Land disposal, as defined in 40 <i>CFR</i> § 268.2, of restricted hazardous soils— <b>applicable</b> .	40 <i>CFR</i> § 268.49(b) 401 <i>KAR</i> 37:040 §10	✓	✓	✓	✓	✓	✓	✓
Disposal of RCRA hazardous debris in a land-based unit	Must be treated prior to land disposal as provided in 40 <i>CFR</i> § 268.45(a)(1)-(5) unless EPA determines under 40 <i>CFR</i> § 261.3(f)(2) that the debris no longer contaminated with hazardous waste <u>or</u> the debris is treated to the waste-specific treatment standard provided in 40 <i>CFR</i> § 268.40 for the waste contaminating the debris.	Land disposal, as defined in 40 <i>CFR</i> § 268.2, of RCRA-hazardous debris— <b>applicable</b> .	40 <i>CFR</i> § 268.45(a) 401 <i>KAR</i> 37:040 §7		✓	✓	✓	✓	✓	✓

**Table 4.2. Action-specific ARARs for the Oil Landfarm and the C-720 Northeast and Southeast Sites (Continued)**

Action	Requirement	Prerequisite	Citation	Alt 2	Alt 3	Alt 4	Alt 5	Alt 6	Alt 7	Alt 8
Disposal of RCRA characteristic wastewaters in an NPDES permitted wastewater treatment unit	Are not prohibited, if the wastes are managed in a treatment system which subsequently discharges to waters of the U.S. pursuant to a permit issued under 402 of the CWA (i.e., NPDES permitted) unless the wastes are subject to a specified method of treatment other than DEACT in 40 <i>CFR</i> § 268.40, or are D003 reactive cyanide.  NOTE: For purposes of this exclusion, a CERCLA on-site wastewater treatment unit that meets all of the identified CWA ARARs for point source discharges from such a system, is considered a wastewater treatment system that is NPDES permitted.	Land disposal of hazardous wastewaters that are hazardous only because they exhibit a hazardous characteristic and are not otherwise prohibited under 40 <i>CFR</i> Part 268— <b>applicable</b> .	40 <i>CFR</i> § 268.1(c)(4)(i) 401 <i>KAR</i> 37:010 §2				✓		✓	
Disposal of bulk PCB remediation waste off-site (self-implementing)	May be sent off-site for decontamination or disposal provided the waste either is dewatered on-site or transported off-site in containers meeting the requirements of DOT HMR at 49 <i>CFR</i> parts 171-180.	Generation of bulk PCB remediation waste (as defined in 40 <i>CFR</i> § 761.3) for off-site disposal— <b>relevant and appropriate</b> .	40 <i>CFR</i> § 761.61(a)(5)(i)(B)	✓	✓	✓	✓	✓	✓	✓
	Must provide written notice including the quantity to be shipped and highest concentration of PCBs [using extraction EPA Method 3500B/3540C or Method 3500B/3550B followed by chemical analysis using Method 8082 in SW-846 or methods validated under 40 <i>CFR</i> § 761.320-26 (Subpart Q)] before the first shipment of waste to each off-site facility where the waste is destined for an area not subject to a TSCA PCB Disposal Approval.	Bulk PCB remediation waste (as defined in 40 <i>CFR</i> § 761.3) destined for an off-site facility not subject to a TSCA PCB Disposal Approval— <b>relevant and appropriate</b> .	40 <i>CFR</i> § 761.61(a)(5)(i)(B)(2)(iv)	✓	✓	✓	✓	✓	✓	✓
	Shall be disposed of in accordance with the provisions for cleanup wastes at 40 <i>CFR</i> § 761.61(a)(5)(v)(A).	Off-site disposal of dewatered bulk PCB remediation waste with a PCB concentration < 50 ppm— <b>relevant and appropriate</b> .	40 <i>CFR</i> § 761.61(a)(5)(i)(B)(2)(ii)	✓	✓	✓	✓	✓	✓	✓

**Table 4.2. Action-specific ARARs for the Oil Landfarm and the C-720 Northeast and Southeast Sites (Continued)**

Action	Requirement	Prerequisite	Citation	Alt 2	Alt 3	Alt 4	Alt 5	Alt 6	Alt 7	Alt 8
	Shall be disposed of <ul style="list-style-type: none"> <li>in a hazardous waste landfill permitted by EPA under §3004 of RCRA;</li> </ul>	Off-site disposal of dewatered bulk PCB remediation waste with a PCB concentration ≥ 50 ppm— <b>relevant and appropriate.</b>	40 <i>CFR</i> § 761.61(a)(5)(i)(B)(2)(iii)	✓	✓	✓	✓	✓	✓	✓
	<ul style="list-style-type: none"> <li>in a hazardous waste landfill permitted by a State authorized under §3006 of RCRA; or</li> </ul>			✓	✓	✓	✓	✓	✓	✓
	<ul style="list-style-type: none"> <li>in a PCB disposal facility approved under 40 <i>CFR</i> § 761.60.</li> </ul>			✓	✓	✓	✓	✓	✓	✓
Disposal of liquid PCB remediation waste (self-implementing)	Shall either <ul style="list-style-type: none"> <li>decontaminate the waste to the levels specified in 40 <i>CFR</i> § 761.79(b)(1) or (2); or</li> </ul>	Liquid PCB remediation waste (as defined in 40 <i>CFR</i> § 761.3)— <b>relevant and appropriate.</b>	40 <i>CFR</i> § 761.61(a)(5)(iv) 40 <i>CFR</i> § 761.61(a)(5)(iv)(A)	✓	✓	✓	✓	✓	✓	✓
	<ul style="list-style-type: none"> <li>dispose of the waste in accordance with the performance-based requirements of 40 <i>CFR</i> § 761.61(b) or in accordance with a risk-based approval under 40 <i>CFR</i> § 761.61(c).</li> </ul>		40 <i>CFR</i> § 761.61(a)(5)(iv)(B)	✓	✓	✓	✓	✓	✓	✓
Performance-based disposal of PCB remediation waste	May dispose by one of the following methods <ul style="list-style-type: none"> <li>in a high-temperature incinerator under 40 <i>CFR</i> § 761.70(b);</li> </ul>	Disposal of non-liquid PCB remediation waste (as defined in 40 <i>CFR</i> § 761.3)— <b>applicable.</b>	40 <i>CFR</i> § 761.61(b)(2) 40 <i>CFR</i> § 761.61(b)(2)(i)	✓	✓	✓	✓	✓	✓	✓
	<ul style="list-style-type: none"> <li>by an alternate disposal method under 40 <i>CFR</i> § 761.60(e);</li> </ul>			✓	✓	✓	✓	✓	✓	✓
	<ul style="list-style-type: none"> <li>in a chemical waste landfill under 40 <i>CFR</i> § 761.75;</li> </ul>			✓	✓	✓	✓	✓	✓	✓
	<ul style="list-style-type: none"> <li>in a facility under 40 <i>CFR</i> § 761.77; or</li> </ul>			✓	✓	✓	✓	✓	✓	✓
	<ul style="list-style-type: none"> <li>through decontamination in accordance with 40 <i>CFR</i> § 761.79.</li> </ul>		40 <i>CFR</i> § 761.61(b)(2)(ii)	✓	✓	✓	✓	✓	✓	✓

**Table 4.2. Action-specific ARARs for the Oil Landfarm and the C-720 Northeast and Southeast Sites (Continued)**

Action	Requirement	Prerequisite	Citation	Alt 2	Alt 3	Alt 4	Alt 5	Alt 6	Alt 7	Alt 8
	Shall be disposed according to 40 <i>CFR</i> § 761.60(a) or (e), or decontaminate in accordance with 40 <i>CFR</i> § 761.79.	Disposal of liquid PCB remediation waste— <b>applicable</b> .	40 <i>CFR</i> § 761.61(b)(1)	✓	✓	✓	✓	✓	✓	✓
Risk-based disposal of PCB remediation waste	May dispose of in a manner other than prescribed in 40 <i>CFR</i> § 761.61(a) or (b) if approved in writing from EPA and method will not pose an unreasonable risk of injury to [sic] human health or the environment. <i>NOTE:</i> EPA approval of alternative disposal method will be obtained by approval of the FFA CERCLA document.	Disposal of PCB remediation waste— <b>applicable</b> .	40 <i>CFR</i> § 761.61(c)	✓	✓	✓	✓	✓	✓	✓
Disposal of PCB cleanup wastes (e.g., PPE, rags, non-liquid cleaning materials) (self-implementing option)	Shall be disposed of <ul style="list-style-type: none"> <li>in a municipal solid waste facility under 40 <i>CFR</i> § 258 or non-municipal, nonhazardous waste subject to 40 <i>CFR</i> § 257.5 thru 257.30; or</li> <li>in a RCRA Subtitle C landfill; or</li> <li>in a PCB disposal facility; or</li> <li>through decontamination under 40 <i>CFR</i> § 761.79(b) or (c).</li> </ul>	Generation of non-liquid PCBs during and from the cleanup of PCB remediation waste— <b>relevant and appropriate</b> .	40 <i>CFR</i> § 761.61(a)(5)(v)(A)	✓	✓	✓	✓	✓	✓	✓
Disposal of PCB cleaning solvents, abrasives, and equipment (self-implementing option)	May be reused after decontamination in accordance with 40 <i>CFR</i> § 761.79; or For liquids, disposed in accordance with 40 <i>CFR</i> § 761.60(a).	Generation of PCB wastes from the cleanup of PCB remediation waste— <b>relevant and appropriate</b> .	40 <i>CFR</i> § 761.61(a)(5)(v)(B) 40 <i>CFR</i> § 761.60(b)(1)(i)(B)	✓	✓	✓	✓	✓	✓	✓
Disposal of PCB decontamination waste and residues	Shall be disposed of at their existing PCB concentration unless otherwise specified in 40 <i>CFR</i> § 761.79(g)(1) through (6).	PCB decontamination waste and residues for disposal— <b>applicable</b> .	40 <i>CFR</i> § 761.79(g)	✓	✓	✓	✓	✓	✓	✓
Disposal of LLW	LLW shall be certified as meeting waste acceptance requirements before it is transferred to the receiving facility.	Disposal of LLW at a LLW disposal facility— <b>TBC</b> .	DOE M 435.1-1(IV)(J)(2)	✓	✓	✓	✓	✓	✓	✓

**Table 4.2. Action-specific ARARs for the Oil Landfarm and the C-720 Northeast and Southeast Sites (Continued)**

Action	Requirement	Prerequisite	Citation	Alt 2	Alt 3	Alt 4	Alt 5	Alt 6	Alt 7	Alt 8
<i>Decontamination/Cleanup</i>										
Decontamination of movable equipment contaminated by PCBs (self-implementing option)	May decontaminate by <ul style="list-style-type: none"> <li>• swabbing surfaces that have contacted PCBs with a solvent;</li> <li>• a double wash/rinse as defined in 40 <i>CFR</i> § 761.360-378; or</li> <li>• another applicable decontamination procedure under 40 <i>CFR</i> § 761.79.</li> </ul>	Movable equipment contaminated by PCB and tools and sampling equipment— <b>applicable</b> .	40 <i>CFR</i> § 761.79(c)(2)	✓	✓	✓	✓	✓	✓	✓
Decontamination of PCB containers (self-implementing option)	Must flush the internal surfaces of the container three times with a solvent containing < 50 ppm PCBs. Each rinse shall use a volume of the flushing solvent equal to approximately 10% of the PCB container capacity.	PCB Container as defined in 40 <i>CFR</i> § 761.3— <b>applicable</b> .	40 <i>CFR</i> § 761.79(c)(1)	✓	✓	✓	✓	✓	✓	✓
Decontamination of PCB contaminated water	For discharge to a treatment works as defined in 40 <i>CFR</i> § 503.9 (aa), or discharge to navigable waters, meet standard of < 3 ppb PCBs; or	Water containing PCBs regulated for disposal— <b>applicable</b> .	40 <i>CFR</i> § 761.79(b)(1)(ii)	✓	✓	✓	✓	✓	✓	✓
	The decontamination standard for water containing PCBs is less than or equal to 0.5 µg/L (i.e., approximately ≤0.5 ppb PCBs) for unrestricted use.		40 <i>CFR</i> § 761.79(b)(1)(iii)	✓	✓	✓	✓	✓	✓	✓
<i>Unit Closure</i>										
Closure performance standard for RCRA container storage unit	Must close the facility (e.g., container storage unit) in a manner that: <ul style="list-style-type: none"> <li>• Minimizes the need for further maintenance;</li> <li>• Controls minimizes or eliminates to the extent necessary to protect human health and the environment, post-closure escape of hazardous waste, hazardous constituents, leachate, contaminated run-off, or hazardous waste decomposition products to the ground or surface waters or the atmosphere; and</li> <li>• Complies with the closure requirements of this subpart, but not limited to, the requirements of 40 <i>CFR</i> 264.178 for containers.</li> </ul>	Storage of RCRA hazardous waste in containers— <b>applicable</b> .	40 <i>CFR</i> 264.111 401 <i>KAR</i> 34:070 § 2	✓	✓	✓	✓	✓	✓	✓

**Table 4.2. Action-specific ARARs for the Oil Landfarm and the C-720 Northeast and Southeast Sites (Continued)**

Action	Requirement	Prerequisite	Citation	Alt 2	Alt 3	Alt 4	Alt 5	Alt 6	Alt 7	Alt 8
Closure of RCRA container storage unit	At closure, all hazardous waste and hazardous waste residues must be removed from the containment system. Remaining containers, liners, bases, and soils containing or contaminated with hazardous waste and hazardous waste residues must be decontaminated or removed.  [Comment: At closure, as throughout the operating period, unless the owner or operator can demonstrate in accordance with 40 <i>CFR</i> 261.3(d) of this chapter that the solid waste removed from the containment system is not a hazardous waste, the owner or operator becomes a generator of hazardous waste and must manage it in accordance with all applicable requirements of parts 262 through 266 of this chapter].	Storage of RCRA hazardous waste in containers in a unit with a containment system— <b>applicable</b> .	40 <i>CFR</i> 264.178 401 <i>KAR</i> 34:180 § 9	✓	✓	✓	✓	✓	✓	✓
Clean closure of TSCA storage facility	A TSCA/RCRA storage facility closed under RCRA is exempt from the TSCA closure requirements of 40 <i>CFR</i> 761.65(e).	Closure of TSCA/RCRA storage facility— <b>applicable</b> .	40 <i>CFR</i> 761.65(e)(3)	✓	✓	✓	✓	✓	✓	✓
<b>Waste transportation</b>										
Transportation of samples (i.e., contaminated soils and wastewaters)	Are not subject to any requirements of 40 <i>CFR</i> Parts 261 through 268 or 270 when: <ul style="list-style-type: none"> <li>The sample is being transported to a laboratory for the purpose of testing; or</li> <li>The sample is being transported back to the sample collector after testing.</li> </ul>	Samples of solid waste <u>or</u> a sample of water, soil for purpose of conducting testing to determine its characteristics or composition— <b>applicable</b> .	40 <i>CFR</i> § 261.4(d)(1)(i) and (ii)	✓	✓	✓	✓	✓	✓	✓



**Table 4.2. Action-specific ARARs for the Oil Landfarm and the C-720 Northeast and Southeast Sites (Continued)**

Action	Requirement	Prerequisite	Citation	Alt 2	Alt 3	Alt 4	Alt 5	Alt 6	Alt 7	Alt 8
	<p>In order to qualify for the exemption in paragraphs (d)(1)(i) and (ii), a sample collector shipping samples to a laboratory must:</p> <ul style="list-style-type: none"> <li>Comply with U.S. DOT, U.S. Postal Service, or any other applicable shipping requirements.</li> <li>Assure that the information provided in (1) thru (5) of this section accompanies the sample.</li> <li>Package the sample so that it does not leak, spill, or vaporize from its packaging.</li> </ul>		<p>40 <i>CFR</i> § 261.4(d)(2)(i)            40 <i>CFR</i> § 261.4(d)(2)(i)(A)            40 <i>CFR</i> § 261.4(d)(2)(i)(B)</p>	✓	✓	✓	✓	✓	✓	✓
Transportation of RCRA hazardous waste on-site	The generator manifesting requirements of 40 <i>CFR</i> §§ 262.20–262.32(b) do not apply. Generator or transporter must comply with the requirements set forth in 40 <i>CFR</i> § 263.30 and 263.31 in the event of a discharge of hazardous waste on a private or public right-of-way.	Transportation of hazardous wastes on a public or private right-of-way within or along the border of contiguous property under the control of the same person, even if such contiguous property is divided by a public or private right-of-way— <b>applicable.</b>	<p>40 <i>CFR</i> § 262.20(f)            401 <i>KAR</i> 32:020 § 1</p>	✓	✓	✓	✓	✓	✓	✓
Transportation of RCRA hazardous waste off-site	Must comply with the generator requirements of 40 <i>CFR</i> § 262.20–23 for manifesting, § 262.30 for packaging, § 262.31 for labeling, § 262.32 for marking, § 262.33 for placarding, § 262.40, 262.41(a) for record keeping requirements, and § 262.12 to obtain EPA ID number.	Preparation and initiation of shipment of hazardous waste off-site— <b>applicable.</b>	<p>40 <i>CFR</i> § 262.10(h)            401 <i>KAR</i> 32:010 § 1</p>	✓	✓	✓	✓	✓	✓	✓
Transportation of PCB wastes off-site	Must comply with the manifesting provisions at 40 <i>CFR</i> § 761.207 through 218.	Relinquishment of control over PCB wastes by transporting, or offering for transport— <b>applicable.</b>	<p>40 <i>CFR</i> § 761.207(a)</p>	✓	✓	✓	✓	✓	✓	✓

**Table 4.2. Action-specific ARARs for the Oil Landfarm and the C-720 Northeast and Southeast Sites (Continued)**

Action	Requirement	Prerequisite	Citation	Alt 2	Alt 3	Alt 4	Alt 5	Alt 6	Alt 7	Alt 8
Determination of radionuclide concentration	The concentration of a radionuclide may be determined by an indirect method, such as use of a scaling factor which relates the inferred concentration of one (1) radionuclide to another that is measured or radionuclide material accountability if there is reasonable assurance that an indirect method may be correlated with an actual measurement.  The concentration of a radionuclide may be averaged over the volume or weight of the waste if the units are expressed as nanocuries per gram.	Preparation for off-site shipment of LLW to a commercial NRC or Agreement State licensed disposal facility— <b>relevant and appropriate.</b>	10 <i>CFR</i> § 61.55 (a)(8)  902 <i>KAR</i> 100:021 § 6(8)(a) and (b)	✓	✓	✓	✓	✓	✓	✓
Labeling of LLW packages	Each package of waste shall be clearly labeled to identify if it is Class A, Class B, or Class C waste, in accordance with 10 <i>CFR</i> § 61.55 or Agreement State waste classification requirements.	Preparation for off-site shipment of LLW to a commercial NRC or Agreement State licensed disposal facility— <b>relevant and appropriate.</b>	10 <i>CFR</i> § 61.57  902 <i>KAR</i> 100:021 § 8	✓	✓	✓	✓	✓	✓	✓
Transportation of radioactive waste	Shall be packaged and transported in accordance with DOE Order 460.1B and DOE Order 460.2.	Preparation of shipments of radioactive waste— <b>TBC.</b>	DOE M 435.1-(I)(1)(E)(11)	✓	✓	✓	✓	✓	✓	✓
Transportation of LLW	To the extent practicable, the volume of the waste and the number of the shipments shall be minimized.	Preparation of shipments of LLW— <b>TBC.</b>	DOE M 435.1-1(IV)(L)(2)	✓	✓	✓	✓	✓	✓	✓
Transportation of hazardous materials	Shall be subject to and must comply with all applicable provisions of the HMR at 49 <i>CFR</i> §§ 171–180 related to marking, labeling, placarding, packaging, emergency response, etc.	Any person who, under contract with a department or agency of the federal government, transports “in commerce,” or causes to be transported or shipped, a hazardous material— <b>applicable.</b>	49 <i>CFR</i> § 171.1(c)	✓	✓	✓	✓	✓	✓	✓

**Table 4.2. Action-specific ARARs for the Oil Landfarm and the C-720 Northeast and Southeast Sites (Continued)**

Action	Requirement	Prerequisite	Citation	Alt 2	Alt 3	Alt 4	Alt 5	Alt 6	Alt 7	Alt 8
Transportation of hazardous materials on-site	Shall comply with 49 <i>CFR</i> Parts 171-174, 177, and 178 or the site- or facility-specific Operations of Field Office approved Transportation Safety Document that describes the methodology and compliance process to meet equivalent safety for any deviation from the Hazardous material Regulations [i.e., <i>Transportation Safety Document for On-Site Transport within the Paducah Gaseous Diffusion Plant</i> , PRS-WSD-0661, (PRS 2007)].	Any person who, under contract with the DOE, transports a hazardous material on the DOE facility— <b>TBC</b> .	DOE O 460.1B(4)(b)	✓	✓	✓	✓	✓	✓	✓
Transportation of hazardous materials off-site	Off-site hazardous materials packaging and transfers shall comply with 49 <i>CFR</i> Parts 171-174, 177, and 178 and applicable tribal, State, and local regulations not otherwise preempted by DOT and special requirements for Radioactive Material Packaging.	Preparation of off-site transfers of LLW— <b>TBC</b> .	DOE O 460.1B(4)(a)	✓	✓	✓	✓	✓	✓	✓

ALARA = as low as reasonably achievable

ARAR = applicable or relevant and appropriate requirement

BMP = best management practices

BPJ = best professional judgment

CERCLA = Comprehensive Environmental Response, Compensation and Liability Act

*CFR* = Code of Federal Regulations

CWA = Clean Water Act

DOE = U.S. Department of Energy

DOE O = DOE Order

DOE M = DOE Manual

DOT = U.S. Department of Transportation

EDE = effective dose equivalent

EPA = U.S. Environmental Protection Agency

E.O. = Executive Order

HAP = hazardous air pollutant

HMR = hazardous material regulations

*KAR* = Kentucky Administrative Regulations

KPDES = Kentucky Pollutant Discharge Elimination System

LLW = low-level waste

NPDES = Pollutant Discharge Elimination System

NRC = Nuclear Regulatory Commission

NWP = Nationwide Permit

PCB = polychlorinated biphenyl

PGDP = Paducah Gaseous Diffusion Plant

PPE = personal protective equipment

RCRA = Resource Conservation and Recovery Act

ROD = Record of Decision

TBC = to be considered

TSCA = Toxic Substances Control Act

*USC* = United States Code

UTS = Universal Treatment Standards

VOC = volatile organic compounds

VOHAP = volatile organic hazardous air pollutant

WAC = waste acceptance criteria

AOC policy is further summarized in the National Oil and Hazardous Substances Pollution Contingency Plan (NCP). See 53 *FR* 51444 for detailed discussion in proposed NCP preamble; or 55 *FR* 8758-8760, March 8, 1990, for final NCP preamble discussion. See also, EPA guidance, March 13, 1996, EPA memo, "Use of the Area of Contamination Concept During RCRA Cleanups."

The AOC policy has direct application to certain remedial alternatives/activities associated with this proposed response action. The RAWP will provide additional details on application of the AOC policy for this project.

#### **4.1.2.3 Long-term effectiveness and permanence**

Long-term effectiveness and permanence is the anticipated ability of the alternatives to maintain reliable protection of human health and the environment, once the RAOs are met. Alternatives will be assessed for the long-term effectiveness and permanence they afford, along with the degree of certainty that the alternative will prove successful. The following are factors that may be considered in this assessment:

- The magnitude of residual risk from untreated wastes or treatment residuals remaining at the conclusion of the remedial activities, including their volumes, toxicities, and mobilities.
- The adequacy and reliability of controls such as containment systems necessary to manage treatment residuals and untreated wastes. For example, this factor addresses uncertainties associated with land disposal for providing long-term protection from residuals; the assessment of the potential need to replace technical components of the alternative, such as a cover or treatment system; and the potential exposure pathways and risks posed should the remedial action need replacement.

#### **4.1.2.4 Reduction of toxicity, mobility, or volume through treatment**

The degree to which the alternatives employ treatment or recycling that reduces toxicity, mobility, or volume will be assessed, including how the treatment is used to address the principal threats posed by the release sites. Factors that will be considered, as appropriate, include the following:

- Treatment or recycling processes that the alternatives employ and the materials that they will treat;
- The amount of hazardous substances, pollutants, or contaminants that will be destroyed or recycled;
- The degree of expected reduction in toxicity, mobility, or volume of waste due to treatment or recycling and the specification of which reductions are occurring;
- The degree to which the treatment is irreversible;
- The type and quantity of residuals that will remain following treatment, taking into consideration the persistence, toxicity, mobility, and propensity to bioaccumulate such hazardous substances and their constituents; and
- The degree to which treatment reduces the inherent hazards posed by the principal threats at the release sites.

Reduction of the volume or mass of VOCs present in the UCRS for alternatives implementing treatment was estimated using removal efficiencies for the primary technologies, as reported in previous field-scale treatability studies or remedial actions and from analytical solutions to the governing equations for the treatment processes.

#### **4.1.2.5 Short-term effectiveness**

Short-term effectiveness during implementation of the remedial action will be assessed, including the following:

- Short-term risks that might be posed to the community;
- Potential risks or hazards to workers, and the effectiveness and reliability of protective measures;
- Potential environmental effects and the effectiveness and reliability of mitigative measures; and
- Time until remedy protectiveness is achieved.

Short-term effectiveness can be improved by the use of administrative or engineering controls in that protectiveness can be quickly established by eliminating the potential for a completed exposure pathway.

#### **4.1.2.6 Implementability**

The ease or difficulty of implementing the alternatives will be assessed by considering the following types of factors, as appropriate:

- Technical feasibility, including the technical difficulties and unknowns associated with constructing and operating the technology, reliability of the technology, ease of undertaking additional remedial actions, and ability to monitor the effectiveness of the remedy.
- Administrative feasibility, including activities required to coordinate with other offices and agencies and the ability and time needed to obtain any necessary approvals and permits for off-site actions from other agencies.
- Availability of required materials and services.

#### **4.1.2.7 Cost**

Supporting calculations for conceptual designs, including cost estimates, are provided in Appendix B. These are the types of costs assessed:

- RD and construction documentation costs, including RD, construction management and oversight, RD and remedial action document preparation, project/program management and oversight, and reporting costs;
- Construction costs, including capital equipment, general and administrative costs, and construction subcontract fees;
- Operating and maintenance costs;
- Equipment replacement costs; and
- Surveillance and monitoring costs.

Life-cycle costs are presented as constant value fiscal year (FY) 2010 dollars; escalated value FY 2010 dollars; and present worth for capital, O&M, and periodic costs for each alternative. Escalation was applied as directed by DOE Order 430.1A, "Life Cycle Asset Management." Escalation rates were obtained at "Escalation Rate Assumptions for DOE Projects (January 2009)" accessed at <http://www.cfo.doe.gov/cf70/escalation.pdf>. Long-term costs of maintenance and monitoring were

estimated for 30 years as applicable, as recommended by CERCLA guidance (EPA 1988). A contingency of 25% was applied to the escalated life-cycle cost of each alternative.

Present worth costs were calculated as described in EPA (2000b) guidance. The discount rate of 2.7% was used [obtained from OMB Circular A-94 Appendix C (OMB 2008)].

Detailed total costs for implementing each alternative at the Oil Landfarm and the C-720 Northeast and Southeast Sites are presented in Appendix B. Summary costs for implementing each alternative at each individual source area are presented in this section and in Section 5.

The alternative cost estimates are for comparison purposes only and are not intended for budgetary, planning, or funding purposes. Estimates were prepared to meet the -30% to +50% range of accuracy recommended in EPA (1988) CERCLA guidance. Detailed cost estimate backup is provided in Appendix B.

#### **4.1.2.8 State acceptance**

This assessment evaluates the technical and administrative issues and concerns the Commonwealth of Kentucky may have regarding each of the alternatives. This criterion will be addressed in the Proposed Plan and the Responsiveness Summary of the ROD after Commonwealth of Kentucky comments on the FFS and Proposed Plan are received and after the public comment period has ended.

#### **4.1.2.9 Community acceptance**

This assessment evaluates the issues and concerns the public may have regarding each of the alternatives. As with state acceptance, this criterion will be addressed in the responsiveness summary of the ROD after public comments on the FFS, the Proposed Plan, and information contained in the Administrative Record are received.

### **4.1.3 Federal Facility Agreement and NEPA Requirements**

Specific requirements of the FFA and NEPA, consistent with the DOE's Secretarial Policy Statement on NEPA in June of 1994, will be considered in the FFS. The subsequent sections address these requirements.

#### **4.1.3.1 Otherwise required permits under the FFA**

When DOE proposes a response action, Section XXI of the FFA further requires that DOE identify each state and federal permit that otherwise would have been required in the absence of CERCLA Section 121(e)(1) and the NCP. DOE must identify the permits that otherwise would be required and the standards, requirements, criteria, or limitations necessary to obtain such permits and must provide an explanation of how the proposed action will meet the standards, requirements, criteria, or limitations identified.

An evaluation of alternatives evaluated in the FFS determined that the otherwise required permits may include KPDES; RCRA Treatment, Storage, and Disposal Facility; and Solid Waste Landfill permits. Jurisdictional wetlands have been identified on PGDP and will be further delineated, as necessary, prior to the remedial action.

PGDP currently operates under KPDES Permit No. KY0004049, Hazardous Waste Facility Operating Permit No. KY8-890-008-982, and Solid Waste Permit No. 07300045, which define the applicable

standards, requirements, criteria, or limitations. In the absence of the existing permits, the substantive requirements of the otherwise required permits are identified in the ARARs provided for each alternative.

#### 4.1.3.2 NEPA values

The following NEPA values, not normally addressed by CERCLA documentation, also are considered in this FS to the extent practicable, consistent with DOE policy:

- Land use
- Air quality and noise
- Geologic resources and soils
- Water resources
- Wetlands and floodplains
- Ecological resources
- Threatened and Endangered (T&E) species
- Migratory birds
- Cultural and archeological resources
- Socioeconomics, including environmental justice and transportation

Alternatives 1 through 8 would have no identified short-term or long-term impacts on geological resources, cultural resources, or socioeconomics. Upon final selection of the alternative, the absence of any short- and long-term impacts to these values will be verified.

No long-term impacts to air quality or noise would result from implementation of the remedial action alternatives evaluated. Process engineering controls and remedial actions should not result in generation of air pollutants above regulatory limits, and noise levels should be similar to current background levels.

None of the remedial alternatives would have any impacts on geologic resources, and construction activities would have only short-term impacts on soils. Site clearing, excavation, grading, and contouring would alter the topography of the construction area, but the geologic formations underlying those sites should not be affected. Construction would disturb existing soils, and some topsoil might be removed in the process. Soil erosion impacts during construction would be mitigated through the use of BMP control measures (e.g., covers and silt fences). No conversion of prime farmland soils is expected to occur. Any alternative that would create disturbances also would include restoration of the affected areas.

None of the activities associated with the remedial alternatives would be conducted within a floodplain. Wetlands were identified during the 1994 COE environmental investigation for the area surrounding the PGDP. This investigation identified five acres of potential wetlands inside the fence at the PGDP (COE 1994) including wetlands along the southern and eastern boundaries of the Oil Landfarm. The COE made the determination that these areas are jurisdictional wetlands (COE 1995).

Construction activities must avoid or minimize adverse impacts on wetlands and act to preserve and enhance their natural and beneficial values (Executive Order 11990 and 10 *CFR* § 1022). These applicable requirements include avoiding construction in wetlands, avoiding (to the extent practicable) long- and short-term adverse impacts to floodplains and wetlands, avoiding degradation or destruction of wetlands, and avoiding discharge of dredge and fill material into wetlands. In addition, the protection of wetlands shall be incorporated into all planning documents and decision making, as required by 10 *CFR* § 1022.3.

No long- or short-term impacts have been identified to archeological or cultural resources. DOE developed the CRMP (BJC 2006) to define the preservation strategy for PGDP and direct efficient

compliance with the NHPA and federal archaeological protection legislation at PGDP. No archaeological or historical resources have been identified within the vicinity of the Oil Landfarm or the C-720 Northeast and Southeast Sites; however, should portions of the project remove soils that previously have been undisturbed, an archaeological survey will be conducted in accordance with the CRMP. If archaeological properties are located that will be affected adversely, then appropriate mitigation measures will be employed.

Executive Order 12898, *Federal Actions to Address Environmental Justice in Minority Populations and Low Income Populations*, requires agencies to identify and address disproportionately high and adverse human health or environmental effects their activities may have on minority and low-income populations. There is a disproportionately high percentage of minority and low-income populations within 50 miles of the PGDP site (DOE 2004), but because there are no potential impacts from these alternatives, there would be no disproportionate or adverse environmental justice impacts to these populations associated with this alternative.

No long- or short-term adverse transportation impacts are expected to result from implementation of remedial alternatives. During construction activities there would be a slight increase in the volume of truck traffic in the vicinity of the Oil Landfarm or the C-720 Northeast and Southeast Sites, but the affected roads are capable of handling the additional truck traffic. Any wastes transferred off-site or transported in commerce along public rights-of-ways will meet both substantive and administrative ARARs. These include the permitting, packaging, labeling, marking, manifesting, and placarding requirements for hazardous materials at 49 *CFR* Parts 107, 171–174, and 178; however, transport of wastes along roads within the PGDP site that are not accessible to the public would not be considered “in commerce” and would, therefore, only need to meet the substantive requirements of the regulations.

In addition, CERCLA 121(d)(3) provides that the off-site transfer of any hazardous substance, pollutant, or contaminant generated during CERCLA response actions be sent to a treatment, storage, or disposal facility that complies with applicable federal and state laws and has been approved by the EPA for acceptance of CERCLA waste. Accordingly, DOE will verify with the appropriate EPA regional contact that any needed off-site facility is acceptable for receipt of CERCLA wastes before transfer.

#### **4.1.3.3 Natural Resources Damage Assessment**

As part of the overall FS process, a preliminary analysis was conducted of each alternative’s impact on natural resources, including each alternative’s potential to avoid, mitigate, compensate for, or cause a natural resource injury. This initial evaluation found that no alternative is expected to cause long-term damage to natural resources. Furthermore, the analysis revealed that all alternatives, with the exception of Alternatives 1 and 2 (No Further action and Long-term Monitoring), are expected to have a positive impact on the groundwater natural resource and are expected to be neutral with respect to the other natural resources. The most significant positive impact to natural resources offered by the alternatives is the mitigation or the removal of existing sources of groundwater contamination; five of the eight alternatives offer one of these advantages. Table 4.3 summarizes the results of the analysis. Further integration may be included in subsequent documents, as appropriate.



**Table 4.3. Remedial Alternatives\* and the Relative Impacts on Natural Resource**

	Alternative 1	Alternative 2	Alternative 3	Alternative 4	Alternative 5	Alternative 6	Alternative 7	Alternative 8
Natural Resource	No Further Action	Long-term Monitoring	In <i>situ</i> Source Treatment Using Deep Soil Mixing	Source Removal and In <i>situ</i> Chemical Source Treatment	In <i>situ</i> Thermal Source Treatment	In <i>situ</i> Source Treatment Using LAI	In <i>situ</i> Soil Flushing and Source Treatment Using Multiphase Extraction	In <i>situ</i> Source Treatment Using EISB
Groundwater	Neutral	Neutral	Positive	Positive	Positive	Positive	Positive	Positive
Surface Water	Neutral	Neutral	Neutral	Neutral	Neutral	Neutral	Neutral	Neutral
Air	Neutral	Neutral	Neutral	Neutral	Neutral	Neutral	Neutral	Neutral
Biological	Neutral	Neutral	Neutral	Neutral	Neutral	Neutral	Neutral	Neutral
Geological	Neutral	Neutral	Neutral	Neutral	Neutral	Neutral	Neutral	Neutral

\*Alternatives 2 through 8 include use of interim LUCs.

EISB = enhanced *in situ* bioremediation

LAI = liquid atomized injection

## 4.2 MODELING RESULTS

Because the remediation technologies under consideration for implementation for the Southwest Plume sources likely will not reduce subsurface soil VOC levels to the remedial goal concentration within the anticipated period of active treatment, the time required for residual VOC mass to attenuate advectively over time and demonstrate remedy compliance with RAO #3 was assessed. This assessment focuses on the contribution of VOC mass leaching to the RGA from the individual Southwest Plume sources, irrespective of ambient VOC contamination in the RGA. Contributions of leached residual VOC mass from these sources were deterministically assessed in terms of time required to achieve sub-MCL concentrations in the RGA below the treatment area. The modeling methodology and results, including discussion of uncertainty, are provided in Appendix C and are summarized in Table 4.4. The time required for leached residual VOC mass to diminish to levels that are less than the MCL in the RGA below the source areas was estimated for each alternative and each site using TCE half-lives of 5, 25, and 50 years to assess the potential effects of degradation on remedy time frames. Other VOCs were assumed not to be degraded. Any contamination from upgradient sources was not accounted for. An uncertainty analysis was conducted using probabilistic analyses.

Recently, as part of the development of response actions including the Southwest Plume SI, DOE completed fate and transport modeling for PGDP using revised biodegradation rates for the RGA. The revised biodegradation rates were developed using regulator accepted methods presented in *Technical Protocol for Evaluating Natural Attenuation of Chlorinated Solvents in Groundwater* (EPA 1998b) and data from the Northwest Plume, the most thoroughly characterized of the dissolved-phase plumes at PGDP. Sampling results collected from the Northwest Plume indicate that TCE concentrations decrease with distance at a faster rate than selected inorganic contaminants (i.e., chloride and Tc-99). Analyses using these inorganic tracers yielded a dissolved-phase TCE degradation factor with a range of 0.0614 to 0.2149 year<sup>-1</sup>. This degradation factor corresponds to a TCE half-life of 11.3 to 3.2 years, respectively. Appendix F of the Southwest Plume SI presents a detailed discussion of the derivation of this degradation rate.

**Table 4.4. Time to Attainment of MCLs for VOCs in the RGA from Oil Landfarm and C-720 Area Sources**

Remedial Alternatives*	Expected Reduction in Soil Contaminant Concentrations, %	Years to reach MCL in RGA Groundwater		
		5 Year Half-Life	25 Year Half-Life	50 Year Half-Life
<b>Oil Landfarm</b>				
Alternative 2—Long term monitoring	0	41	>100	>100
Alternative 3— <i>In situ</i> source treatment using deep soil mixing	91	25	68	87
Alternative 4—Source removal and <i>in situ</i> chemical source treatment	100 in excavated column, 0 in native soils	15	38	50
Alternative 5— <i>In situ</i> thermal source treatment	98	1	39	50
Alternative 8— <i>In situ</i> source treatment using EISB	60	35	93	>100
<b>C-720 Northeast and Southeast Sites</b>				
Alternative 2—Long-term monitoring	0	35	97	>100
Alternative 5— <i>In situ</i> thermal source treatment	98	0	20	29
Alternative 6— <i>In situ</i> source treatment using LAI	90	18	52	67
Alternative 7— <i>In situ</i> soil flushing and source treatment using multiphase extraction	95	0	39	51

\*Alternatives evaluated include use of interim LUCs.

MCL = maximum contaminant level

RGA = Regional Gravel Aquifer

EISB = enhanced *in situ* bioremediation

A review of existing literature regarding chemical and physical parameters, including half-lives, for TCE was conducted for the California Environmental Protection Agency and presented in *Intermedia Transfer Factors for Contaminants Found at Hazardous Waste Sites: Trichloroethylene (TCE), Final Draft Report* (Cal/EPA 1994). Reaction half-life values reported in scientific literature were compiled and averaged. Reported values for the reaction half-life of TCE in vadose-zone soil ranged from 33 to 2888 days (approximately 0.09 to 7.9 years) with a mean of 760 days (approximately 2.1 years). The reported values for the reaction half-life of TCE in groundwater were very similar, ranging from 128 to 2888 days (approximately 0.35 to 7.9 years) with a mean of 800 days (approximately 2.2 years). Biodegradation half-lives can vary dramatically in response to site specific geochemical conditions; thus, experiences at other locations may not be reliably applied to the PGDP site.

The actual degradation rate of TCE in the UCRS has not been determined. Investigation of TCE degradation in the UCRS is ongoing. The 50 year half-life is conservative value unlikely to be exceeded at Paducah given the various evaluation and based on literature values discussed in Claussen *et al.* (1997), the KRCEE (2008) evaluation of biodegradation in the RGA, and values used in TCE transport model development. This FFS estimates the time to attain MCLs for TCE in groundwater below the source areas

using three half-lives (5, 25, and 50 years) for comparative analysis of alternatives. In the following sections, the time to attain MCLs for TCE in groundwater is estimated using a 25 year half-life, only as a means for alternative comparison. The time estimates determined using the 25 year half-life are more illustrative of the differences between the remedy time frames than the those determined using the 50 year half-life.

### **4.3 DETAILED ANALYSIS OF ALTERNATIVES**

The following sections will provide individual detailed analyses of each alternative based on the criteria listed in Section 4.1.

#### **4.3.1 Alternative 1—No Further Action**

##### **4.3.1.1 Overall protection of human health and the environment**

Alternative 1 would not meet this threshold criterion. No administrative or engineering controls would be implemented as part of the alternative; thus, there would be the potential for an unacceptable risk to excavation workers and off-site residents. The presence of daughter products of anaerobic biodegradation of chlorinated solvents and other markers of anaerobic biodegradation (i.e., carbon disulfide) indicates conditions suitable for enhanced anaerobic biodegradation are present at some locations in the vicinity of the Oil Landfarm; however, aerobic conditions found in some of the UCRS and in most of the RGA are not amenable to rapid natural degradation of TCE contamination. RAOs would not be met because no action would be implemented to reliably reduce exposures and attain RGs.

##### **4.3.1.2 Compliance with ARARs**

Alternative 1 would not meet this threshold criterion because no action would be implemented to reliably reduce exposures and attain RGs. No administrative or engineering controls would be implemented as part of the alternative; thus, there would be the potential for an unacceptable risk to excavation workers and off-site residents.

##### **4.3.1.3 Long-term effectiveness and permanence**

Alternative 1 does not reduce the flux of VOCs to the RGA. TCE groundwater protection RGs would not be attained for approximately 100 years or more. Once the VOC contamination has migrated to the RGA at a level that causes groundwater protection RGs to be met, it would be expected that VOCs would have been reduced to protective levels; however, this protectiveness would be not achieved for more than 100 years.

##### **4.3.1.4 Reduction of toxicity, mobility, or volume through treatment**

Treatment would not be implemented with Alternative 1. Reduction in contaminant mass and concentration would be achieved only very slowly through natural attenuation processes, such as dilution, dispersion, and biodegradation of VOCs in UCRS soils and groundwater.

##### **4.3.1.5 Short-term effectiveness**

No further actions would be implemented under Alternative 1; therefore, no additional risks to workers, the public, or the environment would be incurred. No administrative or engineering controls would be

implemented as part of alternative; thus, there would be the potential for an unacceptable risk to excavation workers and off-site residents. Modeling results presented in Appendix C estimate that Alternative 1 would require over 100 years to meet groundwater protection RGs, based on a TCE half-life of 25 years; therefore, Alternative 1 ranks poorly in meeting short-term effectiveness because the time to achieving protectiveness is very long.

No ecological impacts at the Oil Landfarm are anticipated under this alternative. The Oil Landfarm and C-720 Northeast and Southeast sites are located at an active operational facility already disturbed by construction and operational activities and do not support any unique or significant ecological resources. No known archaeological or historical sites or T&E species would be impacted by this alternative.

#### **4.3.1.6 Implementability**

Alternative 1 would involve no actions and is therefore technically implementable.

#### **4.3.1.7 Cost**

No costs are associated with Alternative 1.

### **4.3.2 Alternative 2—Long-term Monitoring with Interim LUCs**

#### **4.3.2.1 Overall protection of human health and the environment**

Alternative 2 would meet this threshold criterion. Monitoring and interim LUCs would remain in use until final remedy selection as part of subsequent OUs that would address the relevant media. Interim LUCs will provide notice and warning of environmental contamination for any residual or remaining VOC and non-VOC contamination that is not treated by this remedial action and has concentrations that prevent unrestricted use/unlimited exposure in the Southwest Plume Source areas. The Southwest Plume sites are located more than one mile from any current residential population, and effects on outlying communities would be negligible because of the continued access restrictions and groundwater use restrictions in the area from the PGDP Water Policy that would eliminate the exposure risks.

RAO #1 would not be met because no removal or treatment of VOC contamination is included in Alternative 2; however, other PGDP Site remedial activities do incorporate treatment of DNAPL and affected groundwater. RAO #2a would be met by implementation of the E/PP program until final disposition through the Soils OU. RAO #2b would be met through use of interim LUCs, including the E/PP program and warning signs.

RAO #3 would not be met because no reduction of VOC migration from contaminated subsurface soils in at the Oil Landfarm and C-720 Northeast and Southeast Sites would occur as part of the remedial action.

#### **4.3.2.2 Compliance with ARARs**

Alternative 2 would meet this threshold criterion. Table 4.2 summarizes compliance with ARARs for Alternative 2.

#### **4.3.2.3 Long-term effectiveness and permanence**

The long-term effectiveness and permanence of Alternative 2 is moderate to low for the Oil Landfarm and the C-720 Northeast and Southeast Sites. Protection of human health is expected to be reliably maintained by implementation of interim LUCs until final remedy selection as part of subsequent OUs

that would address the relevant media. Interim LUCs will provide notice and warning of environmental contamination for any residual or remaining VOC and non-VOC contamination that is not treated by this remedial action and has concentrations that prevent unrestricted use/unlimited exposure in the Southwest Plume Source areas. Alternative 2 does not provide long-term controls to reduce flux of VOCs to the RGA. Natural attenuation processes (e.g., degradation, migration, and dispersion) are expected to have a minimal impact on VOC contamination in the UCRS. Interim LUCs would be employed to prevent the completion of exposure pathways to workers and off-site residents until final remedy selection as part of subsequent OUs that would address the relevant media.

The time required to reach TCE groundwater protection RGs following completion of this remedial alternative is estimated at over 100 years at the C-720 Northeast and Southeast Sites and 97 years at the Oil Landfarm, assuming a 25-year half-life for TCE, as reported in Appendix C. This timeline may be reduced by remedial actions implemented as part of subsequent OUs that would address relevant media. Non-VOC concentrations would not be reduced; however, the interim LUCs (E/PP program and warning signs) would limit exposures pending final remedy selection as part of subsequent OUs that would address relevant media. Five-year reviews and monitoring would be required as long as soil concentrations remained above groundwater protection RGs.

#### **4.3.2.4 Reduction of toxicity, mobility, or volume through treatment**

Treatment would not be implemented with Alternative 2. Reduction in contaminant mass and concentration would be achieved only through natural attenuation processes, such as degradation, migration, and dispersion of VOCs in UCRS soils and groundwater.

#### **4.3.2.5 Short-term effectiveness**

The short-term effectiveness of Alternative 2 is moderate to low for the Oil Landfarm and the C-720 Northeast and Southeast Sites. Short-term effectiveness would be achieved through the use of interim LUCs, which can be implemented quickly, but require maintenance. No treatment would be implemented under Alternative 2. Natural attenuation processes (e.g., degradation, migration, and dispersion) would have little to no impact on VOC contamination in the UCRS in the short term; however, no additional risks to the public or the environment would be incurred. Potential risks or hazards to workers would be relatively minimal. Possible hazards during drilling or groundwater sampling activities would be managed appropriately. In addition, the Southwest Plume sites are located more than one mile from any residential population, and effects on outlying communities would be negligible because the PGDP Water Policy (not part of this action) continues to provide water to residents, access restrictions, and groundwater use restrictions in the PGDP area, which eliminate groundwater exposure risks.

Five-year reviews and monitoring would be required as long as concentrations of contaminants in soil remained above RGs. The time required to reach TCE groundwater protection RGs following completion of this remedial alternative is estimated at over 100 years at the C-720 Northeast and Southeast Sites and 97 years at the Oil Landfarm, assuming a 25 year half-life for TCE, as reported in Appendix C.

No ecological impacts at the Oil Landfarm are anticipated under this alternative. The Oil Landfarm and C-720 Northeast and Southeast sites are located at an active operational facility already disturbed by construction and operational activities and do not support any unique or significant ecological resources. No known archaeological or historical sites or T&E species would be impacted by this alternative. Although standard construction techniques would be utilized to prevent contaminated materials from migrating to the nearby drainageways, risk assessment and mitigation for ecological receptors in nearby drainage ditches are within the scope of the Surface Water OU.

#### 4.3.2.6 Implementability

Alternative 2 would require the implementation of groundwater monitoring, interim LUCs, and five-year reviews, and is therefore technically implementable.

#### 4.3.2.7 Cost

Estimated construction and O&M costs for Alternative 2 are summarized in Table 4.5. O&M costs for 30 years following completion of the remedial action are included in the summary. O&M costs for 30 years include groundwater monitoring activities. Unescalated, escalated, and present value analyses are provided.

**Table 4.5. Summary of Estimated Costs for Alternative 2**

Cost element <sup>1</sup>	C-720 Northeast Site (\$M)	C-720 Southeast Site (\$M)	Oil Landfarm
<b>Unescalated Cost</b>			
Capital cost	\$1.0	\$1.0	\$1.0
O&M	\$1.2	\$1.2	\$1.2
<b>Subtotal</b>	<b>\$2.1</b>	<b>\$2.1</b>	<b>\$2.1</b>
<b>Escalated Cost</b>			
Capital cost	\$1.0	\$1.0	\$1.0
O&M	\$1.2	\$1.2	\$1.2
<b>Subtotal</b>	<b>\$2.2</b>	<b>\$2.2</b>	<b>\$2.2</b>
<b>Present Worth<sup>2</sup></b>			
Capital cost	\$1.0	\$1.0	\$1.0
O&M	\$0.8	\$0.8	\$0.8
<b>Subtotal</b>	<b>\$1.7</b>	<b>\$1.7</b>	<b>\$1.7</b>

<sup>1</sup>Includes general and administrative fee and 15% contingency.

<sup>2</sup>Present worth costs are based on an assumption that outyear costs will be financed by investments made in year 0 and are provided for purposes of comparison only. The discount rate used for calculation of Present worth was 2.7%. Escalated costs are used by DOE for planning and budgeting.

### 4.3.3 Alternative 3—*In situ* Source Treatment Using Deep Soil Mixing with Interim LUCs

#### 4.3.3.1 Overall protection of human health and the environment

Alternative 3 would meet this threshold criterion. Monitoring and interim LUCs would remain in use until final remedy selection as part of subsequent OUs that would address the relevant media. Interim LUCs will provide notice and warning of environmental contamination for any residual or remaining VOC and non-VOC contamination that is not treated by this remedial action and has concentrations that prevent unrestricted use/unlimited exposure in the Southwest Plume Source areas. The Southwest Plume sites are located more than one mile from any current residential population, and effects on outlying communities would be negligible because the PGDP Water Policy (not part of this action) continues to provide water to residents, access restrictions, and groundwater use restrictions in the PGDP area, which eliminate groundwater exposure risks.

Deep soil mixing would reduce VOC source mass by *in situ* treatment of contamination present in soils and groundwater in the UCRS. Alternative 3 would address all phases of contamination present (i.e., vapor, sorbed, dissolved, and DNAPL) through physical mixing of an amendment throughout the entire depth of contamination present in the UCRS.

RAO #1 would be met by treatment of TCE (including PTW) using *in situ* soil mixing. RAO #2a would be met by treating VOCs to levels below the worker protection RG. RAO #2b would be supplemented by the E/PP program until final disposition through the Soils OU.

RAO #3 would be met by VOC treatment and immobilization. Up to 91% of the VOCs present likely would be removed during the process of mixing based on results of previous implementation elsewhere (see Table 4.6). This treatment efficiency also is based on 96% estimated removal of VOC contamination in the mixed areas and approximately 50% estimated removal of VOC contamination present in the interstitial areas (interstitial areas represent approximately 10% of the source area volume).

#### **4.3.3.2 Compliance with ARARs**

Alternative 3 would meet this threshold criterion. Table 4.2 summarizes compliance with ARARs for Alternative 3.

#### **4.3.3.3 Long-term effectiveness and permanence**

The long-term effectiveness and permanence of Alternative 3 is moderate to high. Protection of human health is expected to be reliably maintained by implementation of interim LUCs until final remedy selection as part of subsequent OUs that would address the relevant media. Interim LUCs will provide notice and warning of environmental contamination for any residual or remaining VOC and non-VOC contamination that is not treated by this remedial action and has concentrations that prevent unrestricted use/unlimited exposure in the Southwest Plume Source areas. Overall treatment efficiency for Alternative 3 is estimated at up to 91%, based on reports for previous applications (Table 4.6). Residual VOC contamination remaining after completion of the remedial action would continue to be reduced by groundwater that encounters residual reagent in the saturated zone. In unsaturated portions of the treated soils, potential residual contamination would be immobilized by injection of a bentonite slurry.

The time required to reach TCE groundwater protection RGs at the Oil Landfarm following completion of this remedial alternative is estimated at 68 years, assuming a 25-year half-life for TCE, as reported in Appendix C. This timeline may be reduced by remedial actions implemented as part of subsequent OUs that would address relevant media. Non-VOC concentrations would not be reduced; however, the interim LUCs (E/PP program and warning signs) would limit exposures pending final remedy selection as part of subsequent OUs that would address relevant media. Five-year reviews and monitoring would be required as long as concentrations of contaminants in soil remained above RGs.

#### **4.3.3.4 Reduction of toxicity, mobility, or volume through treatment**

Alternative 3 includes treatment of VOC contamination present in the saturated and unsaturated portions of the UCRS. In addition, a direct reduction in the mobility of contamination would be achieved by injection of bentonite slurry throughout the depth of the mixing column. Additionally, construction of a cement cap in the top 10 ft bgs could be designed either to allow or limit infiltration. Infiltration through the treated areas potentially could continue to reduce VOC mass by coming into contact with residual reagent; the limiting of infiltration would work to further reduce mobility of vadose zone contamination.

**Table 4.6. Case Study Evaluation—Deep Soil Mixing**

Case Study Evaluation—Deep Soil Mixing								
Case Study	% Efficiency Removal	General Lithology	Homogeneous or Heterogeneous	Saturated or Unsaturated conditions	Initial Soil Concentrations	Final Soil Concentrations	Contaminant(s)	Amendment
Camp Lejeune	91% reduction in PCE in overall treatment area based on weighted average soil concentrations; 82% reduction based on average; >99% reduction outside SEAR* area; 61% reduction inside SEAR* area.	Silty-clay layer 20 ft bgs	NA	NA	~1000-1200 mg/kg	~0-500 mg/kg	DNAPL, PCE (and TCE, DCE, VC)	ZVI-Clay
US Army Intelligence Base—performed by Geo-Solutions (report—Dec 2006)	92-99.4% reduction in VOCs	Clayey soils	NA	NA	250-10,000 ug/kg	NA	Chlorinated solvents and VOCs	2% ZVI, bentonite clay, small amt emulsified vegetable oil

NA – Information not available

\*Remnants of previous surfactant-enhanced aquifer remediation (SEAR) test may have interfered with the ZVI.

DCE = dichloroethene

DNAPL = dense non-aqueous phase liquid

DOD = U.S. Department of Defense

PCE = perchloroethene

TCE = trichloroethene

VC = vinyl chloride

VOC= volatile organic compounds

ZVI = zero-valent iron



Overall removal efficiency is estimated at up to 91% based on reports for previous applications (Table 4.6). Depending on the reagent utilized during the soil mixing process, non-VOC contamination such as metals potentially could be mobilized (oxidant reagents) or precipitated (ZVI reagent). In either case, the injection of a bentonite slurry would immobilize non-VOC contamination present at the Oil Landfarm.

Wastes produced as a result of the soil mixing process are estimated to be approximately 30% of the volume of material added to the subsurface. These spoils would be containerized, sampled, and disposed of at an appropriate on-site or off-site disposal facility.

Secondary wastes would include drill cuttings produced during MW installation, PPE, and decontamination fluids. For cost-estimating purposes, drill cuttings, PPE, and decontamination fluids were assumed to require containerization, dewatering, and testing prior to off-site disposal as mixed waste. Actual dispositioning requirements would be determined during RD and by sampling of containerized soils.

#### **4.3.3.5 Short-term effectiveness**

The short-term effectiveness of Alternative 3 is moderate to high. Short-term effectiveness would be established quickly through implementation of interim LUCs. Implementation of Alternative 3 has relatively low potential for remediation worker exposure to soil contamination during the *in situ* soil mixing process. Exposure to contaminated surface soils, subsurface soils, and groundwater during environmental sampling also would be low. Potential exposure pathways include inhalation of dust containing surficial soils, and dermal contact with surficial and subsurface soils. While estimated risks associated with these exposures are greater than Alternatives 1 or 2, they are much less than excavation (Alternative 4) due to the *in situ* nature of treatment. In addition, short-term effectiveness is moderate to high because remediation risks and potential completed exposure pathways are considered manageable because interim LUCs (E/PP Program) provide measures for protection of site workers. The deep soil mixing process and groundwater monitoring activities would be conducted by trained personnel in accordance with appropriate procedures and safe work practices to minimize injury or exposure risks. Wastes generated as a result of remedial activities would be managed in accordance with a waste characterization plan and waste management plan prepared during the RD/RAWP. Site preparation and the soil mixing process are expected to require approximately 4 months.

Monitoring and soil mixing process controls would be protective of the public throughout construction and implementation of the remedy. The Southwest Plume sites are not located near any residential population, and effects on outlying communities would be negligible because of the continued access restrictions, which would eliminate the exposure risks.

Five-year reviews and monitoring would be required as long as concentrations of contaminants in soil remained above RGs. The time required to reach TCE groundwater protection RGs at the Oil Landfarm following completion of this remedial alternative is estimated at 68 years for the Oil Landfarm, assuming a 25 year half-life for TCE, as reported in Appendix C. Warning signs and the E/PP program would protect workers pending remedy selection as part of subsequent OUs that addresses relevant media.

No ecological impacts at the Oil Landfarm are anticipated under this alternative. The Oil Landfarm is located at an active operational facility already disturbed by construction and operational activities and does not support any unique or significant ecological resources. No known archaeological or historical sites or T&E species would be impacted by this alternative. Although standard construction techniques would be utilized to prevent contaminated materials from migrating to the nearby drainageways, risk assessment and mitigation for ecological receptors in nearby drainage ditches are within the scope of the Surface Water OU.

#### 4.3.3.6 Implementability

Overall implementability of Alternative 3 is moderate to low, but technically feasible. The overall effort to mobilize and operate required equipment is greater than that of Alternatives 1 or 2, but less than that of Alternatives 4 or 5. The alternative consists of demonstrated technologies, standard construction methods, materials, and equipment that are available from vendors and contractors.

#### 4.3.3.7 Cost

Estimated construction and O&M costs for Alternative 3 are summarized in Table 4.7. O&M costs for 30 years following completion of the remedial action are included in the summary. O&M costs for 30 years include groundwater monitoring activities. Unescalated, escalated, and present value analyses are provided.

**Table 4.7. Summary of Estimated Costs for Alternative 3**

Cost element <sup>1</sup>	Oil Landfarm (\$M)
<b>Unescalated Cost</b>	
Capital cost	\$8.3
O&M	\$1.2
<b>Total</b>	<b>\$9.5</b>
<b>Escalated Cost</b>	
Capital cost	\$8.6
O&M	\$1.2
<b>Total</b>	<b>\$9.7</b>
<b>Present Worth<sup>2</sup></b>	
Capital cost	\$8.3
O&M	\$0.8
<b>Total</b>	<b>\$9.1</b>

<sup>1</sup>Includes general and administrative fee and 15% contingency.

<sup>2</sup>Present worth costs are based on an assumption that outyear costs will be financed by investments made in year 0 and are provided for purposes of comparison only. The discount rate used for calculation of Present worth was 2.7%. Escalated costs are used by DOE for planning and budgeting.

#### 4.3.4 Alternative 4—Source Removal and *In situ* Chemical Source Treatment with Interim LUCs

##### 4.3.4.1 Overall protection of human health and the environment

Alternative 4 would meet this threshold criterion. Monitoring and interim LUCs would remain in use until final remedy selection as part of subsequent OUs that would address the relevant media. Interim LUCs will provide notice and warning of environmental contamination for any residual or remaining VOC and non-VOC contamination that is not treated by this remedial action and has concentrations that prevent unrestricted use/unlimited exposure in the Southwest Plume Source areas. The Southwest Plume sites are located more than one mile from any current residential population, and effects on outlying communities would be negligible because the PGDP Water Policy (not part of this action) continues to provide water to residents, access restrictions, and groundwater use restrictions in the PGDP area, which eliminate groundwater exposure risks.

This alternative would remove and reduce the VOC mass, including PTW, in source areas in the UCRS, by excavating the source area soils that are contaminated with VOCs above RGs and by treating the

excavation “buffer zone” *in situ*. Alternative 4 would eliminate VOCs present in all phases from the excavated area and reduce contamination present in the buffer zone.

RAO #1 would be met through excavation of source area soils and through “buffer zone” treatment. RAO #2a would be met by treating VOCs to levels below the worker protection RG. RAO #2b would be met by implementation of interim LUCs, including the existing E/PP program and warning signs, pending remedy selection.

RAO #3 would be met with the combination of excavation, presence of a “buffer zone,” treatment of the “buffer zone,” and amendment addition. Although some reduction in VOC contamination in the “buffer zone” would be expected from the addition of amendment, for modeling purposes no reduction was assumed to allow for a conservative estimate of the time to reach soil RGs. A treatment efficiency of 100% can be assumed in the excavated portions of the UCRS. Leaching of VOCs into the RGA would be reduced by excavating only to a depth that would avoid up-welling of contaminated groundwater from the RGA and/or heaving of RGA material into the excavation. The addition of an amendment to the “buffer zone” also would reduce leaching of VOCs into the RGA.

#### **4.3.4.2 Compliance with ARARs**

Alternative 4 would meet this threshold criterion. Table 4.2 summarizes compliance with ARARs for Alternative 4.

#### **4.3.4.3 Long-term effectiveness and permanence**

The long-term effectiveness and permanence of Alternative 4 is moderate to high. VOCs present in the excavated area would be eliminated, and “buffer zone” contamination would be reduced. Protection of human health is expected to be reliably maintained until final remedy selection as part of subsequent OUs that would address the relevant media due to implementation of interim LUCs, removal of contamination in excavated areas, and reduction of contamination in the “buffer zone.” Interim LUCs will provide notice and warning of environmental contamination for any residual or remaining VOC and non-VOC contamination that is not treated by this remedial action and has concentrations that prevent unrestricted use/unlimited exposure in the Southwest Plume Source areas. Overall treatment efficiency for Alternative 4 would be 100% in excavated areas. Although some reduction in contamination would be expected in the “buffer zone” due to the addition of an amendment, no reduction was assumed in modeling simulations. Residual risk from residual VOC contamination remaining after completion of the remedial action would continue to be reduced by groundwater that would encounter residual reagent in the “buffer zone.”

The time required to reach TCE groundwater protection RGs at the Oil Landfarm following completion of this remedial alternative is estimated at 38 years, assuming a 25 year half-life for TCE, as reported in Appendix C. This timeline may be reduced by remedial actions implemented as part of subsequent OUs that would address relevant media. Non-VOC concentrations would be removed in the excavated areas. The potential exists for mobilizing or precipitation of non-VOC constituents, such as metals in the buffer zone, depending on the reagent utilized for treatment. Associated bench-scale studies may be conducted to determine the potential for mobilization of non-VOC constituents and appropriate institutional and/or engineering controls would be utilized to manage this risk. Interim LUCs (E/PP program and warning signs) would limit exposures to non-VOC contamination pending remedy selection as part of subsequent OUs that addresses relevant media. Five-year reviews and monitoring would be required as long as concentrations of contaminants in soil remained above RGs.

#### **4.3.4.4 Reduction of toxicity, mobility, or volume through treatment**

Alternative 4 would eliminate VOCs present in all phases from the excavated area and reduce contamination present in the “buffer zone.” Leaching of VOCs into the RGA would be reduced by excavating only to a depth that would avoid up-welling of contaminated groundwater from the RGA and/or heaving of RGA material into the excavation. The addition of an amendment to the “buffer zone” also would reduce leaching of VOCs into the RGA. Depending on the reagent utilized to treat contamination present in the “buffer zone,” non-VOC contamination such as metals could potentially be mobilized (oxidant reagents) or precipitated (ZVI reagent). Associated bench-scale studies may be conducted to determine the potential for mobilization of non-VOC constituents, and appropriate institutional and/or engineering controls would be utilized to manage this risk.

For costing purposes, it was assumed that wastes would be managed and disposed as 60% mixed waste and 40% nonhazardous waste, pending sampling. Actual disposal requirements would be determined during RD and by sampling of excavated soils.

Secondary wastes would include drill cuttings produced during monitoring well installation, PPE, and decontamination fluids. For cost-estimating purposes, drill cuttings, PPE, and decontamination fluids were assumed to require containerization, dewatering, and testing prior to off-site disposal as mixed waste. Actual dispositioning requirements would be determined during RD and by sampling of containerized soils.

#### **4.3.4.5 Short-term effectiveness**

The short-term effectiveness of Alternative 4 is moderate. Short-term effectiveness would be established quickly through implementation of interim LUCs; however, estimated risks or hazards to workers associated with excavation are greater than those associated with Alternatives 1, 2, 3, 5, and 8. Potential exposure pathways during excavation include inhalation of dust containing surficial soils, and dermal contact with surficial and subsurface soils. Exposure to contaminated surface soils, subsurface soils, and groundwater during environmental sampling would be low. The short-term effectiveness of Alternative 4 is moderate because remediation risks and potential completed exposure pathways are considered manageable due to interim LUCs (E/PP Program) that would provide measures for protection of site workers. Excavation, oxidant addition, and groundwater monitoring activities would be conducted by trained personnel in accordance with appropriate procedures and safe work practices to minimize injury or exposure risks. This alternative relies on establishing and maintaining interim LUCs preventing unauthorized exposure to residual VOC contamination and non-VOC contamination pending remedy selection by subsequent OUs that addresses relevant media or until uncontrolled access is allowed. Wastes generated as a result of remedial activities would be managed in accordance with a waste characterization plan and waste management plan prepared during the RD/RAWP. Site preparation and the excavation/oxidant addition processes are expected to require approximately six months.

Monitoring and excavation process controls would be protective of the public throughout construction and implementation of the remedy. The Southwest Plume sites are not located near any residential population, and effects on outlying communities would be negligible because the PGDP Water Policy (not part of this action) continues to provide water to residents, access restrictions, and groundwater use restrictions in the PGDP area, which eliminate groundwater exposure risks.

Five-year reviews and monitoring would be required as long as concentrations of contaminants in soil remained above RGs. The time required to reach TCE groundwater protection RGs at the Oil Landfarm following completion of this remedial alternative is estimated at 38 years for the Oil Landfarm, assuming

a 25 year half-life for TCE, as reported in Appendix C. The E/PP program will protect workers pending remedy selection as part of subsequent OUs that addresses relevant media.

No ecological impacts at the Oil Landfarm are anticipated under this alternative. The Oil Landfarm is located at an active operational facility already disturbed by construction and operational activities and does not support any unique or significant ecological resources. No known archaeological or historical sites or T&E species would be impacted by this alternative. Although standard construction techniques would be utilized to prevent contaminated materials from migrating to the nearby drainageways, risk assessment and mitigation for ecological receptors in nearby drainage ditches are within the scope of the Surface Water OU.

#### 4.3.4.6 Implementability

Overall implementability of Alternative 4 is moderate to low for the Oil Landfarm. Equipment, personnel, and services required to implement this alternative are readily commercially available. Existing surfaces and infrastructure would be largely affected, and the handling and disposal of waste generated from the excavation would require substantial logistical considerations. Excavated soils would be stockpiled on-site within an AOC consistent with TBC guidance and ARARs, pending disposal. Stockpiles likely would require dust emission controls, as well as storm water runoff controls. For costing purposes, it was assumed that wastes would be managed and disposed of as 60% mixed low-level waste and 40% nonhazardous waste, pending sampling.

#### 4.3.4.7 Cost

Estimated construction and O&M costs for Alternative 4 are summarized in Table 4.8. O&M costs for 30 years following completion of the remedial action are included in the summary. O&M costs for 30 years include groundwater monitoring activities. Unescalated, escalated, and present value analyses are provided.

**Table 4.8. Summary of Estimated Costs for Alternative 4**

<b>Cost element<sup>1</sup></b>	<b>Oil Landfarm (\$M)</b>
<b>Unescalated Cost</b>	
Capital cost	\$10.6
O&M	\$1.2
<b>Total</b>	<b>\$11.8</b>
<b>Escalated Cost</b>	
Capital cost	\$10.9
O&M	\$1.2
<b>Total</b>	<b>\$12.1</b>
<b>Present Worth<sup>2</sup></b>	
Capital cost	\$10.6
O&M	\$0.8
<b>Total</b>	<b>\$11.4</b>

<sup>1</sup>Includes general and administrative fee and 15% contingency.

<sup>2</sup>Present worth costs are based on an assumption that outyear costs will be financed by investments made in year 0 and are provided for purposes of comparison only. The discount rate used for calculation of Present worth was 2.7%. Escalated costs are used by DOE for planning and budgeting.

#### **4.3.5 Alternative 5—*In situ* Thermal Source Treatment with Interim LUCs**

##### **4.3.5.1 Overall protection of human health and the environment**

Alternative 5 would meet this threshold criterion. Monitoring and interim LUCs would remain in use until final remedy selection as part of subsequent OUs that would address the relevant media. Interim LUCs will provide notice and warning of environmental contamination for any residual or remaining VOC and non-VOC contamination that is not treated by this remedial action and has concentrations that prevent unrestricted use/unlimited exposure in the Southwest Plume Source areas. The Southwest Plume sites are located more than one mile from any current residential population, and effects on outlying communities would be negligible because the PGDP Water Policy (not part of this action) continues to provide water to residents, access restrictions, and groundwater use restrictions in the PGDP area, which eliminate groundwater exposure risks.

RAO #1 would be met by removal of PTW as vapor and destroying it *ex situ*. RAO #2a would be met by treating VOCs to levels below the worker protection RG. RAO #2b would be met by interim LUCs (E/PP program and warning signs) until final disposition through subsequent OUs that addresses relevant media.

RAO #3 would be met by reducing VOC soil concentrations to groundwater protection RGs through a combination of active remediation and advective attenuation. Modeling results presented in Appendix C show that after approximately one year of active treatment, residual VOC mass will leach to groundwater in the RGA and attain sub-MCL levels within 20 years at the C-720 Northeast and Southeast Sites and 39 years at the Oil Landfarm. Key assumptions that contribute to the remedy time frame assessment for attainment of RAO #3 include 98% removal efficiency of TCE from UCRS subsurface soil resulting from active treatment as demonstrated in the C-400 Treatability Study.

##### **4.3.5.2 Compliance with ARARs**

Alternative 5 would meet this threshold criterion. Table 4.2 summarizes compliance with ARARs for Alternative 5.

##### **4.3.5.3 Long-term effectiveness and permanence**

The long-term effectiveness and permanence of Alternative 5 is high, because nearly all of the VOCs in the UCRS at the Oil Landfarm source area and the C-720 Northeast and Southeast Sites would be removed by ERH and either destroyed off-site or recycled. Protection of human health is expected to be reliably maintained by implementation of interim LUCs, and reduction in contamination through treatment until final remedy selection as part of subsequent OUs that would address the relevant media. Interim LUCs will provide notice and warning of environmental contamination for any residual or remaining VOC and non-VOC contamination that is not treated by this remedial action and has concentrations that prevent unrestricted use/unlimited exposure in the Southwest Plume Source areas. Overall removal efficiency is estimated at up to 98% over approximately six months, based on results of the C-400 ERH Treatability Study.

The time required to reach TCE groundwater protection RGs following completion of this remedial alternative is estimated at 20 years at the C-720 Northeast and Southeast Sites and 39 years at the Oil Landfarm, assuming a 25-year half-life for TCE, as reported in Appendix C. This timeline may be reduced by remedial actions implemented as part of subsequent OUs that would address relevant media. Non-VOC concentrations would not be reduced; however, the interim LUCs (E/PP program and warning signs) would limit exposures pending final remedy selection as part of subsequent OUs that would

address relevant media. Five-year reviews and monitoring would be required as long as concentrations of contaminants in soil remained above RGs.

#### **4.3.5.4 Reduction of toxicity, mobility, or volume through treatment**

This alternative would remove and destroy most of the VOCs. Overall removal efficiency is estimated at up to 98% over approximately six months, based on results for the C-400 ERH Treatability Study. The ERH system design would include measures to reduce the potential for mobilization of DNAPL TCE during treatment. PCBs and other SVOCs, metals, and radionuclides potentially present at the Oil Landfarm would be expected to remain in the soils and would not be removed in ERH off-gas. Secondary wastes would include approximately 8,165 kg (18,000 pounds) of GAC, drill cuttings produced during electrode/vapor recovery well installation, PPE, and decontamination fluids. For cost-estimating purposes, drill cuttings, PPE, and decontamination fluids were assumed to require containerization, dewatering, and testing prior to off-site disposal as mixed waste. Actual dispositioning requirements would be determined during RD and by sampling of containerized soils. Spent GAC would be properly dispositioned and potentially shipped off-site for regeneration. Condensate would be treated to meet ARARs prior to discharge.

#### **4.3.5.5 Short-term effectiveness**

Short-term effectiveness of Alternative 5 is moderate to high. Short-term effectiveness would be established quickly through implementation of interim LUCs. Installation of electrode/vapor recovery wells and monitoring equipment and groundwater monitoring wells would encounter contaminated soils. Soil returns produced during installation of electrode/vapor recovery wells and groundwater MWs would be managed in accordance with the waste characterization plan, and waste management plan prepared during the RD/RAWP. Installation and operation of the ERH system would be conducted by trained personnel in accordance with appropriate procedures and safe work practices to minimize injury or exposure risks. Worker exposure risks would exist while drilling and installing electrode/vapor recovery wells in contaminated soil areas; also would result in thermal and electrical hazards. The associated increase in requirements for safety analysis, hazard identification, and control would result in increased complexity and cost for implementation; however, all of these issues were successfully resolved for the C-400 ERH Treatability Study. Site preparation and ERH system operation is expected to require approximately one year.

Monitoring and ERH process controls would be protective of the public throughout construction and implementation of the remedy. The Southwest Plume sites are not located near any residential population, and effects on outlying communities would be negligible because of the continued access restrictions, which would eliminate the exposure risks.

Five-year reviews and monitoring would be required as long as concentrations of contaminants in soil remained above RGs. The time required to reach TCE groundwater protection RGs following completion of this remedial alternative is estimated at 39 years for the Oil Landfarm and 20 years for the C-720 Northeast and Southeast sites, assuming a 25 year half-life for TCE, as reported in Appendix C. Warning signs and the E/PP program would protect workers pending remedy selection as part of subsequent OUs that addresses relevant media.

No ecological impacts at the Oil Landfarm are anticipated under this alternative. The Southwest Plume Source Areas are located at an active operational facility already disturbed by construction and operational activities and do not support any unique or significant ecological resources. No known archaeological or historical sites or T&E species would be impacted by this alternative. Although standard construction techniques would be utilized to prevent contaminated materials from migrating to

the nearby drainageways, risk assessment and mitigation for ecological receptors in nearby drainage ditches are within the scope of the Surface Water OU.

#### 4.3.5.6 Implementability

Overall implementability of Alternative 5 is relatively low. Implementability constraints for Alternative 5 would include the technical complexity of the alternative, relatively few vendors offering the technology, and the worker protection issues discussed previously under short-term effectiveness; however, these constraints were resolved for the C-400 ERH Treatability Study. No O&M would be required after completion of the ERH treatment; however, long-term groundwater monitoring and five-year reviews would be required as long as VOC concentrations in soil remained above RGs.

Although implementability is relatively low, existing surfaces and infrastructure would be largely unaffected. Rerouting of utilities would not be required. Equipment, personnel, and services required to implement this alternative are readily commercially available. Field application of the technology at Phase I of the C-400 Interim Remedial Action has provided lessons-learned in the areas of UCRS vacuum extraction well spacing and nuclear safety analysis for USEC facilities that have been incorporated into this analysis. No additional development of these technologies would be required. Contractors possessing the required skills and experience are available.

Administrative feasibility for Alternative 5 is high. The electrode/vapor extraction wells and groundwater monitoring wells would be constructed according to ARARs and abandoned after completion of the project. Recovered vapor would be treated to meet allowable emission levels prior to discharge.

#### 4.3.5.7 Cost

Estimated capital, O&M, and monitoring costs for Alternative 5 are summarized in Table 4.9. Long-term Monitoring for the Oil Landfarm were estimated for 30 years, as recommended by CERCLA guidance (EPA 1988).

**Table 4.9. Summary of Estimated Costs for Alternative 5**

Cost element <sup>1</sup>	C-720 Northeast Site (\$M)	C-720 Southeast Site (\$M)	Oil Landfarm (\$M)
<b>Unescalated Cost</b>			
Capital cost	\$5.7	\$5.7	\$15.5
O&M	\$1.2	\$1.2	\$1.2
<b>Total</b>	<b>\$6.9</b>	<b>\$6.9</b>	<b>\$16.7</b>
<b>Escalated Cost</b>			
Capital cost	\$5.9	\$5.9	\$16.0
O&M	\$1.2	\$1.2	\$1.2
<b>Total</b>	<b>\$7.1</b>	<b>\$7.1</b>	<b>\$17.2</b>
<b>Present Worth<sup>2</sup></b>			
Capital cost	\$5.7	\$5.7	\$15.5
O&M	\$0.8	\$0.8	\$0.8
<b>Total</b>	<b>\$6.5</b>	<b>\$6.5</b>	<b>\$16.3</b>

<sup>1</sup>Includes general and administrative fee and 15% contingency.

<sup>2</sup>Present worth costs are based on an assumption that outyear costs will be financed by investments made in year 0 and are provided for purposes of comparison only. Escalated costs are used by DOE for planning and budgeting.



#### **4.3.6 Alternative 6—*In situ* Source Treatment Using LAI with Interim LUCs**

##### **4.3.6.1 Overall protection of human health and the environment**

Alternative 6 would meet this threshold criterion. Monitoring and interim LUCs would remain in use until final remedy selection as part of subsequent OUs that would address the relevant media. Interim LUCs will provide notice and warning of environmental contamination for any residual or remaining VOC and non-VOC contamination that is not treated by this remedial action and has concentrations that prevent unrestricted use/unlimited exposure in the Southwest Plume Source areas. The Southwest Plume sites are located more than one mile from any current residential population, and effects on outlying communities would be negligible because the PGDP Water Policy (not part of this action) continues to provide water to residents, access restrictions, and groundwater use restrictions in the PGDP area, which eliminate groundwater exposure risks.

This alternative would reduce the VOC mass, including PTW, in source areas in the UCRS, by treating the source area soils that are contaminated with VOCs above RGs *in situ*. Alternative 6 would be capable of treating all phases of contamination present (i.e., vapor, sorbed, dissolved, and DNAPL) through high pressure injection of an amendment into the UCRS. A limitation of the LAI technology is the inability to inject at depths less than 12 ft bgs; however, the E/PP program will protect workers pending remedy selection as part of subsequent OUs that addresses relevant media.

RAO #1 would be met through *in situ* treatment of soils. RAO #2a would be met by treating VOCs to levels below the worker protection RG. RAO #2b would be met by implementation of interim LUCs, including the existing E/PP program and warning signs, pending remedy selection.

RAO #3 would be met by implementing this alternative. A treatment efficiency of up to 90% would be likely based on results of previous implementation elsewhere (Table 4.10). The mass of VOCs leaching into the RGA would be reduced by the injection of an amendment into the subsurface using LAI.

##### **4.3.6.2 Compliance with ARARs**

Alternative 6 would meet this threshold criterion. Table 4.2 summarizes compliance with ARARs for Alternative 6.

##### **4.3.6.3 Long-term effectiveness and permanence**

The long-term effectiveness and permanence of Alternative 6 is moderate. Protection of human health is expected to be reliably maintained until final remedy selection as part of subsequent OUs that would address the relevant media due to implementation of interim LUCs and reduction in contamination from active treatment. Interim LUCs will provide notice and warning of environmental contamination for any residual or remaining VOC and non-VOC contamination that is not treated by this remedial action and has concentrations that prevent unrestricted use/unlimited exposure in the Southwest Plume Source areas. Overall treatment efficiency for Alternative 6 is estimated at up to 90%, based on reports for previous applications (see Table 4.10). Residual VOC contamination remaining after completion of the remedial action would continue to be reduced by groundwater that would encounter residual reagent in the saturated zone. The upper 12 ft bgs would not be treated as part of this alternative.

The time required to reach TCE groundwater protection RGs following completion of this remedial alternative at the C-720 Northeast and Southeast Sites is estimated at 52 years, assuming a 25 year half-life for TCE, as reported in Appendix C. This timeline may be reduced by remedial actions implemented as part of subsequent OUs that would address relevant media. Non-VOC concentrations would not be

**Table 4.10. Case Study Evaluation—Jet-Assisted Injection**

Case Study Evaluation—Jet-assisted Injection								
Case Study	% Efficiency Removal	General Lithology	Homogeneous or Heterogeneous	Saturated or Unsaturated conditions	Initial Soil Concentrations	Final Soil Concentrations	Area of Influence	Comments
NAVFAC: MCLB Albany	99	Clay & silt overlaying chalky limestone	Likely homogeneous	Saturated	5,000-6,500 ug/L	<5 ug/L, initially, but rebound within 1 yr.	Area of influence from injection up to 50 ft.	
White Oak Navy Facility, MD	99	Silty sand & gravel underlain by weathered saprolite		Saturated	535 ug/L	~0 ug/L		
Navy: Hunters Point Shipyard, CA	99	Artificial fill over bedrock		Saturated	88,000 ug/L (mean 27,000 ug/L)	31 ug/L (mean 220 ug/L)	No significant rebound w/in 3 mo. Area of influence from injection 35-40 ft	Actions included pneumatic fracturing before injection
Goodyear Superfund Site, AZ	82-96	Sandy silt, clay		Saturated	510 ug/L	93 ug/L	ZVI nano-scale Area of influence up to 30 ft	
DOD TN	93			Saturated (?)	40,800 ppb		Area of influence 25 ft	
OK Facility	Up to 100%	Clay, silt clay & fine-grained sands interbedded with cemented sandstone	Heterogeneous	Saturated	1,100 ug/L			Actions included pneumatic fracturing before injection
Manufacturing facility, SC	90	Silty clay	Heterogeneous	Unsaturated				Emulsified ZVI (vegetable oil)

reduced; however, the interim LUCs (E/PP program and warning signs) will limit exposures pending remedy selection as part of subsequent OUs that addresses relevant media. Five-year reviews and monitoring would be required as long as concentrations of contaminants in soil remained above RGs.

#### **4.3.6.4 Reduction of toxicity, mobility, or volume through treatment**

This alternative would treat (i.e., oxidize or reduce) VOCs to innocuous byproducts. Overall removal efficiency is estimated at up to 90%. LAI would reduce VOC mass in the UCRS by fracturing low permeability soils and injecting a reagent into the fractures, or mixing a reagent at depths with higher permeability. The distribution of reagent in the subsurface is limited in low permeability soils to the fracture-pathways caused by the pneumatic fracturing process. The resulting estimation of the treatment efficiency is, therefore, more uncertain than with a soil mixing process that does not rely on fracture pathways. Infiltration through the treated areas could potentially continue to reduce VOC mass by coming into contact with residual reagent.

Overall removal efficiency is estimated at up to 90% based on reports for previous applications (Table 4.10). Depending on the reagent utilized during the soil mixing process, non-VOC contamination such as metals potentially could be mobilized (oxidant reagents) or precipitated (ZVI reagent). The LAI RD would include remediating source areas “outward in” and “bottom up,” inherently limiting the potential for contaminant migration outside the source area. PCBs and other SVOCs, metals, and radionuclides potentially present at the Oil Landfarm would be expected to remain in the soils and would not be treated by injection of a reagent. Secondary wastes would include reagent that potentially could daylight through fractures produced during LAI, PPE, and decontamination fluids. For cost-estimating purposes, reagent, PPE, and decontamination fluids were assumed to require containerization, dewatering, and testing prior to off-site disposal of as mixed low-level waste. Actual dispositioning requirements would be determined during RD and by sampling of containerized materials.

Wastes produced as a result of LAI process are estimated to be approximately 1-2 drums of spoils generated per site by the potential day-lighting of reagent through fractures. These spoils would be containerized, sampled, and disposed of at an appropriate on-site or off-site disposal facility.

Secondary wastes would include drill cuttings produced during monitoring well installation, PPE, and decontamination fluids. For cost-estimating purposes, drill cuttings, PPE, and decontamination fluids were assumed to require containerization, dewatering, and testing prior to off-site disposal as mixed waste. Actual dispositioning requirements would be determined during RD and by sampling of containerized soils.

#### **4.3.6.5 Short-term effectiveness**

Short-term effectiveness of Alternative 6 is moderate. Short-term effectiveness would be established quickly through implementation of interim LUCs. Implementation of Alternative 6 has relatively low potential for remediation worker exposure to soil contamination during the *in situ* injection process. Exposure to contaminated surface soils, subsurface soils, and groundwater during environmental sampling is also low. Potential exposure pathways include inhalation of dust containing surficial soils, and dermal contact with surficial and subsurface soils. Estimated risks associated with these exposures are greater than Alternative 1, considerably less than excavation due to the *in situ* nature of treatment, and slightly less than deep soil mixing due to the generation of less spoils. The risks are considered manageable because of the combination of interim LUCs (E/PP Program) and measures taken for protection of site workers. Installation and operation of the LAI equipment and injection events would be conducted by trained personnel in accordance with appropriate procedures and safe work practices to minimize injury or exposure risks. Wastes generated as a result of remedial activities would be managed

in accordance with a waste characterization plan and waste management plan prepared during the RD/RAWP. Site preparation and LAI equipment operation is expected to require approximately one month.

Monitoring and LAI process controls would be protective of the public throughout construction and implementation of the remedy. The Southwest Plume sites are not located near any residential population, and effects on outlying communities would be negligible because of the continued access restrictions which would eliminate the exposure risks.

Five-year reviews and monitoring would be required as long as concentrations of contaminants in soil remained above RGs. The time required to reach TCE groundwater protection RGs following completion of this remedial alternative is estimated at 52 years at the C-720 Northeast and Southeast Sites, assuming a 25 year half-life for TCE, as reported in Appendix C. Warning signs and the E/PP program would protect workers pending remedy selection as part of subsequent OUs that addresses relevant media.

No ecological impacts at the Oil Landfarm are anticipated under this alternative. The Southwest Plume Source Areas are located at an active operational facility already disturbed by construction and operational activities and do not support any unique or significant ecological resources. No known archaeological or historical sites or T&E species would be impacted by this alternative. Although standard construction techniques would be utilized to prevent contaminated materials from migrating to the nearby drainageways, risk assessment and mitigation for ecological receptors in nearby drainage ditches are within the scope of the Surface Water OU.

#### **4.3.6.6 Implementability**

Overall implementability of Alternative 6 is moderate to low. Existing surfaces and infrastructure would be affected to a certain extent, including the storm water lines and sanitary water lines present beneath the C-720 Southeast Site. These utilities most likely would need to be located and rerouted. In addition, a distance of approximately 10 ft would be required between LAI points and the RCW line present at the C-720 Northeast Site. In addition, the LAI points will be maintained at least 15 ft from any buildings. Equipment, personnel, and services required to implement this alternative are commercially available. No additional development of these technologies would be required. Contractors possessing the required skills and experience are available.

#### **4.3.6.7 Cost**

Estimated construction and O&M costs for Alternative 6 are summarized in Table 4.11. O&M costs for 30 years following completion of the remedial action are included in the summary. O&M costs for 30 years include groundwater monitoring activities. Unescalated, escalated, and present value analyses are provided.

### **4.3.7 Alternative 7—*In situ* Soil Flushing and Source Treatment Using Multiphase Extraction with Interim LUCs**

#### **4.3.7.1 Overall protection of human health and the environment**

Alternative 7 would meet this threshold criterion. Monitoring and interim LUCs would remain in use until final remedy selection as part of subsequent OUs that would address the relevant media. Interim LUCs will provide notice and warning of environmental contamination for any residual or remaining VOC and non-VOC contamination that is not treated by this remedial action and has concentrations that prevent unrestricted use/unlimited exposure in the Southwest Plume Source areas. The Southwest Plume

sites are located more than one mile from any current residential population, and effects on outlying communities would be negligible because the PGDP Water Policy (not part of this action) continues to provide water to residents, access restrictions, and groundwater use restrictions in the PGDP area, which eliminate groundwater exposure risks.

**Table 4.11. Summary of Estimated Costs for Alternative 6**

Cost element <sup>1</sup>	C-720 Northeast Site (\$M)	C-720 Southeast Site (\$M)
<b>Unescalated Cost</b>		
Capital cost	\$2.6	\$2.6
O&M	\$1.2	\$1.2
<b>Subtotal</b>	<b>\$3.7</b>	<b>\$3.7</b>
<b>Escalated Cost</b>		
Capital cost	\$2.6	\$2.6
O&M	\$1.2	\$1.2
<b>Subtotal</b>	<b>\$3.8</b>	<b>\$3.8</b>
<b>Present Worth<sup>2</sup></b>		
Capital cost	\$2.6	\$2.6
O&M	\$0.8	\$0.8
<b>Subtotal</b>	<b>\$3.3</b>	<b>\$3.3</b>

<sup>1</sup>Includes general and administrative fee and 15% contingency.

<sup>2</sup>Present worth costs are based on an assumption that outyear costs will be financed by investments made in year 0 and are provided for purposes of comparison only. The discount rate used for calculation of Present worth was 2.7%. Escalated costs are used by DOE for planning and budgeting.

Multiphase extraction would further reduce VOC source mass by removal of all phases of VOC contamination present in the UCRS. Multiphase extraction also would increase the rate of drainage of water of the formation by applying a pressure gradient in addition to the elevation head gradient created by groundwater pumping. Multiphase extraction also would remove water vapor and thereby reduce the soil moisture content. This would further reduce the unsaturated hydraulic conductivity in the unsaturated portions of the treatment areas, resulting in reduced seepage of infiltration to the RGA. Multiphase extraction would increase volatilization rates from DNAPL, sorbed, and aqueous phase VOCs.

RAO #1 would be met by removal of PTW and destroying the VOC contamination *ex situ*. RAO #2a would be met by treating VOCs to levels below the worker protection RG. RAO #2b would be met by the E/PP program until final disposition through the Soils OU.

RAO #3 would be met by VOC removal. Up to 95% of the VOCs present likely would be removed in approximately two years using multiphase extraction, based on results of previous implementation elsewhere (see Table 4.12).

#### **4.3.7.2 Compliance with ARARs**

Alternative 4 would meet this threshold criterion. Table 4.2 summarizes compliance with ARARs for Alternative 4.

#### **4.3.7.3 Long-term effectiveness and permanence**

The long-term effectiveness and permanence of Alternative 4 is moderate to high, because most of the VOCs in the UCRS at the Oil Landfarm source area and the C-720 Northeast and Southeast Sites would

**Table 4.12. Case Study Evaluation–Multiphase Extraction**

Case Study Evaluation : Multiphase Extraction								
Case Study	% Efficiency Removal	General Lithology	Homogeneous or Heterogeneous	Saturated or Unsaturated conditions	Initial Soil Concentrations	Final Soil Concentrations	Ancillary Technologies	Comments
Defense Supply Center, VA	98	Silty clay grading to fine grained sand with interlayered gravel	Heterogeneous	Saturated	890 ug/L	<5ug/L	Dual-phase. No surfactant	
328 Site, Santa Clara, CA	40% from soil 1 <sup>st</sup> month	Tight silty clay	Homogeneous	Both	46 mg/kg soil; 37,000 ug/L groundwater	800 ug/L groundwater	Dual-phase. No surfactant	Soil technology included pneumatic fracturing. Significant soil extraction drop off after 1 <sup>st</sup> month.
Alameda Point Naval Air Station, CA	95% (goal)	Sand & clayey sand	Homogeneous	Both	Soil 70-40,970 (ave. 12,000) mg/kg			
DOE-Paducah	99 (column study)	Thick clayey silts, silt/clay layers with sand & gravel interbeds	Heterogeneous	Unsaturated	225,000 ug/kg		Only column study	
Commercial Dry Cleaning Facility	Unknown; cleaned to regulatory requirement	Below building on silt-clay layer	Homogeneous	Unsaturated	11-27 ppm in soil	Regulatory requirement		

be removed by multiphase extraction and destroyed during the *ex situ* treatment process (Figure 3.14). Protection of human health is expected to be reliably maintained until final remedy selection as part of subsequent OUs that would address the relevant media due to implementation of interim LUCs, and reduction of contamination from active treatment. Interim LUCs will provide notice and warning of environmental contamination for any residual or remaining VOC and non-VOC contamination that is not treated by this remedial action and has concentrations that prevent unrestricted use/unlimited exposure in the Southwest Plume Source areas. Overall removal efficiency for Alternative 7 is estimated at up to 95% over approximately two years, based on reports for previous applications (Table 4.12).

The time required to reach TCE groundwater protection RGs at the C-720 Northeast and Southeast Sites is estimated at 39 years, assuming a 25 year half-life for TCE, as reported in Appendix C. This timeline may be reduced by remedial actions implemented as part of subsequent OUs that would address relevant media. Non-VOC concentrations potentially would be removed during the multiphase extraction and treated by the *ex situ* treatment process (Figure 3.14). The interim LUCs (E/PP program and warning signs) would limit exposures to non-VOC contamination following completion of this remedial alternative, pending remedy selection as part of subsequent OUs that addresses relevant media. Five-year reviews and monitoring would be required as long as concentrations of contaminants in soil remained above RGs.

#### **4.3.7.4 Reduction of toxicity, mobility, or volume through treatment**

This alternative would remove most of the VOCs and thus reduce the mass of VOCs present in the UCRS. Overall removal efficiency is estimated at up to 95% over approximately two years, based on reports for previous applications (Table 4.12). PCBs and other SVOCs, metals, and radionuclides potentially present at the C-720 Northeast and Southeast Sites potentially would be removed in the extracted groundwater. Secondary wastes would include co-produced groundwater, drill cuttings produced during multiphase well installation, PPE, and decontamination fluids. For cost-estimating purposes, drill cuttings, PPE, and decontamination fluids were assumed to require containerization, dewatering, and testing prior to off-site disposal. Actual dispositioning requirements would be determined during RD and by sampling of containerized soils. Coproduced groundwater was assumed to require on-site treatment prior to disposal. Actual treatment requirements would be determined during RD and by sampling and analyzing coproduced groundwater.

#### **4.3.7.5 Short-term effectiveness**

Short-term effectiveness of Alternative 7 is moderate to high. Short-term effectiveness would be established quickly through implementation of interim LUCs. Installation of multiphase wells, groundwater MWs, subsurface piping at C-720 Northeast and Southeast Sites, piezometers, and neutron probe access tubes would encounter contaminated soils. Direct-push equipment would be used to the extent feasible to minimize returns of contaminated soils to the surface and thereby minimize risks to workers. Soil returns produced during installation of multiphase extraction wells would be managed in accordance a waste characterization plan, and a waste management plan, prepared during the RD/RAWP. Work would be conducted by trained personnel in accordance with appropriate procedures such as standard radiological engineering operational procedures, and safe work practices to minimize injury or exposure risks. The E/PP program would protect workers pending remedy selection as part of subsequent OUs that addresses relevant media.

The multiphase extraction wells and groundwater and vapor treatment systems would be operated until concentrations remained asymptotic during pulsed operation. Operation time was estimated to require approximately two years. Five-year reviews and monitoring would be required as long as concentrations of contaminants in soil remained above RGs. The time required to reach TCE groundwater protection

RGs at the C-720 sites is estimated at 39 years, assuming a 25 year half-life for TCE, as reported in Appendix C.

Monitoring, the E/PP program, and multiphase extraction process controls would be protective of the public throughout construction and implementation of the remedy. The Southwest Plume sites are located more than one mile from any residential population, and effects on outlying communities would be negligible because the continued access restrictions and groundwater use restrictions in the area from the PGDP Water Policy would eliminate the exposure risks.

No ecological impacts at the Oil Landfarm are anticipated under this alternative. The Southwest Plume Source Areas are located at an active operational facility already disturbed by construction and operational activities and do not support any unique or significant ecological resources. No known archaeological or historical sites or T&E species would be impacted by this alternative. Although standard construction techniques would be utilized to prevent contaminated materials from migrating to the nearby drainageways, risk assessment and mitigation for ecological receptors in nearby drainage ditches are within the scope of the Surface Water OU.

#### **4.3.7.6 Implementability**

Overall implementability of Alternative 4 is moderate to low. Ongoing operations and subsurface infrastructure at the C-720 Building would constrain implementation at the C-720 Northeast and Southeast Sites. Lining, repair, or replacement of water lines and installation of water meters would remove the lines from service for the duration of construction. Installation of multiphase wells and soil moisture monitoring equipment would require utility location and clearance.

Multiphase extraction wells and groundwater MWs would require periodic submersible pump replacement and potential redevelopment, if the well filter packs became plugged with fines or if screens became iron fouled. The groundwater and vapor treatment systems would require maintenance depending on the specific unit selected, including replacement of the catalytic bed, heat exchanger, and other components. Electricity and natural gas would be ongoing utility requirements for the duration of operation.

Equipment, personnel, and services required to implement this alternative are readily commercially available. No additional development of these technologies, beyond initial air permeability testing, would be required. In general, standard construction practices would be used to implement this alternative, and a sufficient number of contractors possessing the required skills and experience are available.

Administrative feasibility for Alternative 7 is relatively high. Multiphase wells, groundwater MWs, soil gas drive points, piezometers, and neutron probe access tubes would be constructed according to Commonwealth of Kentucky rules and abandoned after completion of the project.

#### **4.3.7.7 Cost**

Estimated construction and O&M costs for Alternative 7 are summarized in Table 4.13. O&M costs for 30 years following completion of the remedial action are included in the summary. O&M costs for 30 years include groundwater monitoring activities. Unescalated, escalated, and present value analyses are provided.



**Table 4.13. Summary of Estimated Costs for Alternative 7**

<b>Cost element<sup>1</sup></b>	<b>C-720 Northeast Site (\$M)</b>	<b>C-720 Southeast Site (\$M)</b>
<b>Unescalated Cost</b>		
Capital cost	\$2.4	\$2.4
O&M	\$1.9	\$1.9
<b>Subtotal</b>	<b>\$4.3</b>	<b>\$4.3</b>
<b>Escalated Cost</b>		
Capital cost	\$2.5	\$2.5
O&M	\$1.9	\$1.9
<b>Subtotal</b>	<b>\$4.4</b>	<b>\$4.4</b>
<b>Present Worth<sup>2</sup></b>		
Capital cost	\$2.4	\$2.4
O&M	\$1.5	\$1.5
<b>Subtotal</b>	<b>\$3.9</b>	<b>\$3.9</b>

<sup>1</sup>Includes general and administrative fee and 15% contingency.

<sup>2</sup>Present worth costs are based on an assumption that outyear costs will be financed by investments made in year 0 and are provided for purposes of comparison only. The discount rate used for calculation of Present worth was 2.7%. Escalated costs are used by DOE for planning and budgeting.

#### **4.3.8 Alternative 8—*In situ* Source Treatment Using EISB with Interim LUCs**

##### **4.3.8.1 Overall protection of human health and the environment**

Alternative 8 would meet this threshold criterion. Monitoring and interim LUCs would remain in use until final remedy selection as part of subsequent OUs that would address the relevant media. Interim LUCs will provide notice and warning of environmental contamination for any residual or remaining VOC and non-VOC contamination that is not treated by this remedial action and has concentrations that prevent unrestricted use/unlimited exposure in the Southwest Plume Source areas. The Southwest Plume sites are located more than one mile from any current residential population, and effects on outlying communities would be negligible because the PGDP Water Policy (not part of this action) continues to provide water to residents, access restrictions, and groundwater use restrictions in the PGDP area, which eliminate groundwater exposure risks.

EISB would reduce VOC source mass by *in situ* treatment of contamination present in soils and groundwater in the UCRS. Alternative 8 would potentially address all phases of contamination present (i.e., vapor, sorbed, dissolved, and DNAPL) through the addition of a bioamendment throughout the entire depth of contamination present in the UCRS.

RAO #1 would be met by treatment VOCs, including PTW, using EISB. RAO #2a would be met by treating VOCs to levels below the worker protection RG. RAO #2b would be met by the E/PP program until final disposition through the Soils OU.

RAO #3 would be met by the addition of a bioamendment into the subsurface at various intervals of contamination present in the UCRS. Alternative 8 would reduce the amount of VOCs leaching into the RGA by reducing the VOC contamination present in the UCRS. Approximately 60% of the VOCs present likely would be removed during EISB based on results of previous implementation elsewhere (Table 4.14).

**Table 4.14. Case Study Evaluation–Bioremediation**

Case Study Evaluation—Bioremediation									
Case Study	% Efficiency Removal	General Lithology	Homogeneous or Heterogeneous	Saturated or Unsaturated Conditions	Initial Soil Concentrations	Final Soil Concentrations	Contaminant(s)	Amendment	Aerobic or Anaerobic
Accelerated Anaerobic Bioremediation at Area 6 of the Dover Air Force Base, Dover, Delaware	All TCE and DCE in groundwater were converted to ethane	Sand with varying amounts of clay, silt, and gravel (Groundwater starting at 10-12 ft bgs)	Varying coarseness of sand	Saturated	(7,500 ug/L TCE in groundwater)		TCE (and PCE, DCE, and VC)	Nonindigenous bacteria, nutrients, lactate	Anaerobic reductive dechlorination (cometabolic and direct)
Cometabolic Bioventing at Building 719, Dover Air Force Base, Dover, Delaware		Sand with varying amounts of clay, silt, and gravel (Groundwater starting at 6-10 ft bgs)	Varying coarseness of sand	Unsaturated	In vadose zone, up to 250 mg/kg TCE, 10-1,000 mg/kg TCA, 1-20 mg/kg DCE  (Up to 19,000 ug/L TCE in groundwater)	<0.25 mg/kg TCE, <0.5 mg/kg TCA, <0.25 mg/kg DCE	TCE; 1,1,1-TCA; <i>cis</i> -1,2-DCE	Oxygen and propane;  Also bioventing	Aerobic oxidation (cometabolic and direct)
Biostimulation and Bioaugmentation : Launch Complex 34 in Cape Canaveral Air Force Station, Florida	98.5% total TCE (and >99% of TCE-DNAPL)	Aquifer 16-24 ft bgs		Saturated?	8,000 mg/kg	<300 mg/kg (indicating no DNAPL)	TCE-DNAPL (and DCE and VC)	Ethanol, KB-1 culture (dechlorinating bacteria)	Anaerobic?
Methane Enhanced Bioremediation Using Horizontal Wells at Savannah River Site, Aiken, SC		Sand, clay, and gravel (Groundwater starting 120-135 ft bgs)	Heterogeneous ?	Saturated (injected in saturated zone, extracted in vadose zone)	0.67-6.29 mg/kg TCE and 0.44-1.05 mg/kg PCE in sediment (10-1,031 ug/L TCE and 3-124 ug/L PCE in groundwater)	Below detectable limits in sediments (below 5 ppb in groundwater)	TCE, PCE	Nutrients, oxygen, and methane	Aerobic oxidation (cometabolic and direct)

#### **4.3.8.2 Compliance with ARARs**

Alternative 8 would meet this threshold criterion. Table 4.2 summarizes compliance with ARARs for Alternative 8.

#### **4.3.8.3 Long-term effectiveness and permanence**

The long-term effectiveness and permanence of Alternative 8 is moderate. Protection of human health is expected to be reliably maintained until final remedy selection as part of subsequent OUs that would address the relevant media due to implementation of interim LUCs and reduction in contamination from active EISB. Interim LUCs will provide notice and warning of environmental contamination for any residual or remaining VOC and non-VOC contamination that is not treated by this remedial action and has concentrations that prevent unrestricted use/unlimited exposure in the Southwest Plume Source areas. Overall treatment efficiency for Alternative 8 at the Oil Landfarm is estimated at up to 60%, based on reports for previous applications (Table 4.14). Residual VOC contamination remaining after completion of the remedial action would continue to be reduced to by groundwater that would encounter residual bioamendment.

The time required to reach TCE groundwater protection RGs at the Oil Landfarm is estimated at 93 years, assuming a 25-year half-life for TCE, as reported in Appendix C. This timeline may be reduced by remedial actions implemented as part of subsequent OUs that would address relevant media. Non-VOC concentrations would not be reduced; however, the interim LUCs (E/PP program and warning signs) will limit exposures pending remedy selection as part of subsequent OUs that addresses relevant media. Five-year reviews and monitoring would be required as long as concentrations of contaminants in soil remained above RGs.

#### **4.3.8.4 Reduction of toxicity, mobility, or volume through treatment**

Alternative 8 includes degradation of VOC contamination present in the saturated and unsaturated portions of the UCRS. Although conditions relatively unfavorable to bio-degradation potentially could exist within the UCRS, the design of the delivery system is meant to provide engineering solutions to these scenarios, to the extent possible. For instance, at the Oil Landfarm, the bioamendment would be introduced at the location that the original source of VOC contamination was allowed to infiltrate into the UCRS. This increases the potential for the bioamendment to follow the same migration pathways as the DNAPL. For this reason, EISB potentially could be implemented with more efficiency at the Oil Landfarm than other source areas at the PGDP (e.g., the C-720 Northeast and Southeast Sites). In addition, by adding enough saturated mixture to several depths within the UCRS, the uncertainty of degradation within the aerobic, unsaturated conditions is reduced. Overall removal efficiency is estimated at 60% based on reports for previous applications (Table 4.14).

Secondary wastes would include drill cuttings produced during MW installation, PPE, and decontamination fluids. For cost-estimating purposes, drill cuttings, PPE, and decontamination fluids were assumed to require containerization, dewatering, and testing prior to off-site disposal as mixed waste. Actual dispositioning requirements would be determined during RD and by sampling of containerized soils.

#### **4.3.8.5 Short-term effectiveness**

The short-term effectiveness of Alternative 8 is moderate to low. Short-term effectiveness would be established quickly through implementation of interim LUCs. Implementation of Alternative 8 has relatively low potential for remediation worker exposure to soil contamination during the EISB process.

Exposure to contaminated surface soils, subsurface soils, and groundwater during environmental sampling is also low. Potential exposure pathways include inhalation of dust containing surficial soils, and dermal contact with surficial and subsurface soils. While estimated risks associated with these exposures are greater than Alternative 1, they are much less than excavation, due to the *in situ* nature of treatment, and are considered manageable because interim LUCs (E/PP Program) provide measures for protection of site workers. The EISB process and groundwater monitoring activities would be conducted by trained personnel in accordance with appropriate procedures and safe work practices to minimize injury or exposure risks. Site preparation and the active EISB remediation are expected to require approximately 2 years.

Monitoring would be protective of the public throughout construction and implementation of the remedy. The Southwest Plume sites are not located near any residential population, and effects on outlying communities would be negligible because of the continued access restrictions that would eliminate the exposure risks.

Five-year reviews and monitoring would be required as long as concentrations of contaminants in soil remained above RGs. The time required to reach TCE groundwater protection RGs at the Oil Landfarm following completion of this remedial alternative is estimated at 93 years, assuming a 25 year half-life for TCE, as reported in Appendix C. Warning signs and the E/PP program would protect workers pending remedy selection as part of subsequent OUs that addresses relevant media.

No ecological impacts at the Oil Landfarm are anticipated under this alternative. The Southwest Plume Source Areas are located at an active operational facility already disturbed by construction and operational activities and do not support any unique or significant ecological resources. No known archaeological or historical sites or T&E species would be impacted by this alternative. Although standard construction techniques would be utilized to prevent contaminated materials from migrating to the nearby drainageways, risk assessment and mitigation for ecological receptors in nearby drainage ditches are within the scope of the Surface Water OU.

#### **4.3.8.6 Implementability**

Overall implementability of Alternative 8 is moderate to high at the Oil Landfarm. The alternative consists of demonstrated technologies, standard construction methods, materials, and equipment that are available from vendors and contractors.

#### **4.3.8.7 Cost**

Estimated construction and O&M costs for Alternative 8 are summarized in Table 4.15. O&M costs for 30 years following completion of the remedial action are included in the summary. O&M costs for 30 years include groundwater monitoring activities. Unescalated, escalated, and present value analyses are provided.

**Table 4.15. Summary of Estimated Costs for Alternative 8**

<b>Cost element<sup>1</sup></b>	<b>Oil Landfarm (\$M)</b>
<b>Unescalated Cost</b>	
Capital cost	\$3.4
O&M	\$2.5
<b>Total</b>	<b>\$5.9</b>
<b>Escalated Cost</b>	
Capital cost	\$3.5
O&M	\$2.6
<b>Total</b>	<b>\$6.1</b>
<b>Present Worth<sup>2</sup></b>	
Capital cost	\$3.4
O&M	\$2.1
<b>Total</b>	<b>\$5.5</b>

<sup>1</sup>Includes general and administrative fee and 25% contingency.

<sup>2</sup>Present worth costs are based on an assumption that outyear costs will be financed by investments made in year 0 and are provided for purposes of comparison only. The discount rate used for calculation of Present worth was 2.7%. Escalated costs are used by DOE for planning and budgeting.

## 5. COMPARATIVE ANALYSIS

The PGDP Southwest Plume source area remedial action alternatives, which were developed in Section 3 and analyzed in detail in Section 4, are compared in this section. The comparative analysis identifies the relative advantages and disadvantages of each alternative, so that the key tradeoffs that risk managers must balance can be identified. The comparative analysis provides a measure of the relative performance of the alternatives against each evaluation criterion.

Alternatives are compared based on two of the three CERCLA categories including threshold criteria and primary balancing criteria. The third category, modifying criteria, including state and community acceptance, will not be addressed until the Proposed Plan has been issued for public review. These modifying criteria will be addressed in the responsiveness summary and the ROD, which will be prepared following the public comment period.

Sections 5.1 and 5.2 present the remedial alternative comparisons relative to each evaluation criterion. Table 3.2 summarizes the relative performance of each alternative for each evaluation criterion.

### 5.1 THRESHOLD CRITERIA

Threshold criteria are of greatest importance in the comparative analysis because they reflect the key statutory mandates of CERCLA, as amended. The threshold criteria that any viable alternative must meet are as follows:

- Overall protection of human health and the environment and
- Compliance with ARARs.

Southwest Plume source area remedial alternatives are evaluated with respect to the threshold criteria in this section. A summary discussion is provided in Table 3.2.

#### 5.1.1 Overall Protection of Human Health and the Environment

This threshold criterion evaluates the ability of an alternative to provide adequate protection of human health and the environment. The overall evaluation primarily draws from assessments of long-term effectiveness and permanence, short-term effectiveness, and compliance with ARARs.

For Alternatives 2 through 8, the use of monitoring and interim LUCs, would assure that risks to workers and off-site residents were controlled until final remedy selection as part of subsequent OUs that would address the relevant media. The Southwest Plume sites are located more than one mile from any current residential population, and effects on outlying communities would be negligible because the PGDP Water Policy (not part of this action) continues to provide water to residents, access restrictions, and groundwater use restrictions in the PGDP area, which eliminate groundwater exposure risks.

Alternatives 3 through 8 would meet the threshold criterion through treatment of VOCs in soil including PTW. The E/PP program and warning signs would protect workers and the public. The mass of non-VOCs would not be reduced by Alternatives 1, 2, 3, 5, 6, or 8; however, interim LUCs (warning signs and E/PP program) would limit exposures pending remedy selection as part of subsequent OUs that addresses relevant media. Non-VOCs would be removed in the excavated material removed during implementation of Alternative 4 and potential extraction and removal of metals during filtration could potentially occur as a result of Alternative 7.

Alternative 1 would not meet the threshold criterion of overall protection of human health and the environment. Alternative 1 would provide no treatment or removal of PTW other than by natural processes, no protection for excavation workers, and no reduction in migration of VOCs to the RGA. Over 100 years would be required to attain MCLs and groundwater protection RGs at the C-720 Northeast and Southeast Sites and at the Oil Landfarm, based on modeling results for a TCE half-life of 25 years.

### **5.1.2 Compliance with ARARs**

Alternative 1 does not meet ARARs, while Alternatives 2 through 8 meet the threshold criterion. Alternatives 2 through 8 also would meet location- and action-specific ARARs through design and planning during preparation of the RD/RAWP.

Although no chemical-specific ARARs were identified, the MCL for TCE and the associated breakdown products was used to develop groundwater protection RGs for site soils.

## **5.2 BALANCING CRITERIA**

The Southwest Plume source area alternatives are compared with respect to the balancing criteria in the following discussion. The primary balancing criteria to which relative advantages and disadvantages of the alternatives are compared include the following:

- Long-term effectiveness and permanence;
- Reduction of toxicity, mobility, and volume through treatment;
- Short-term effectiveness;
- Implementability; and
- Cost.

The first and second balancing criteria address the statutory preference for treatment as a principal element of the remedy and the bias against off-site land disposal of untreated material. Together with the third and fourth criteria, they form the basis for determining the general feasibility of each potential remedy. The final criterion addresses whether the costs associated with a potential remedy are proportional to its overall effectiveness, considering both the cleanup period and O&M requirements during and following cleanup, relative to other alternatives. Key tradeoffs among alternatives will most frequently relate to one or more of the balancing criteria.

### **5.2.1 Long-term Effectiveness and Permanence**

Long-term effectiveness and permanence is the anticipated ability of the alternatives to maintain reliable protection of human health and the environment, once RAOs are met. The overall ranking of Oil Landfarm alternatives with respect to long-term effectiveness and permanence, highest to lowest, is 4, 5, 3, 8, 2, 1. The overall ranking of the C-720 Northeast and Southeast Site alternatives with respect to long-term effectiveness and permanence, highest to lowest, is 5, 7, 6, 2, 1.

Alternatives developed and evaluated for potential implementation at the Oil Landfarm and C-720 Northeast and Southeast Sites provide varying degrees of treatment efficiencies. The treatment efficiencies used to simulate each alternative within the model are based on results of previous implementation elsewhere and are summarized in Appendix C.

Long-term effectiveness and permanence has been evaluated for Alternatives developed for potential implementation at the Oil Landfarm. Alternative 4 or 5 would provide the best long-term effectiveness and permanence for the Oil Landfarm, because groundwater protection RGs could be attained and RAOs met in approximately 38 or 39 years, respectively. Alternative 3 would rank behind Alternatives 4 and 5 with an expected duration of 68 years until groundwater protection RGs could be attained. Alternatives 8 and 2 would provide the least long-term effectiveness, apart from no action, and permanence for the Oil Landfarm due to the length of time until groundwater protection RGs would potentially be met (93 years and greater than 100 years, respectively). Non-VOC concentrations would be reduced by excavation, but not by any other alternatives developed for the Oil Landfarm; however, the E/PP program will limit exposures pending remedy selection as part of subsequent OUs that addresses relevant media.

Long-term effectiveness and permanence has been evaluated for Alternatives developed for potential implementation at the C-720 Northeast and Southeast Sites. Alternative 5 would provide the best long-term effectiveness and permanence for the C-720 Northeast or Southeast Sites, because groundwater protection RGs could be attained and RAOs met in approximately 20 years. Alternative 7 would rank behind Alternative 5 with an expected duration of 39 years until groundwater protection RGs could be attained. Alternative 6 would provide some long-term effectiveness and permanence, but is not as effective as Alternatives 5 or 7. The estimated time until groundwater protection RGs would be met following implementation of Alternative 6 is approximately 52 years. As with the Oil Landfarm, Alternatives 8 and 2 would provide the least long-term effectiveness, apart from no action, and permanence for the C-720 Northeast and Southeast Sites due to the length of time until groundwater protection RGs would potentially be met (81 years and greater than 97 years, respectively). Non-VOC concentrations would not be reduced by Alternatives 2, 5, or 6; however, the E/PP program will limit exposures pending remedy selection as part of subsequent OUs that addresses relevant media. Potential extraction and removal of metals during filtration could potentially occur as a result of Alternative 7.

Alternative 1 would provide no long-term effectiveness or permanence, nor would Alternative 1 provide measures to control risks to workers, off-site residents, or the environment. Attainment of RGs would take over 100 years.

### **5.2.2 Reduction of Toxicity, Mobility, and Volume through Treatment**

The degree to which the alternatives employ treatment or recycling that reduces toxicity, mobility, or volume was assessed in Section 4. The overall ranking of Oil Landfarm alternatives with respect to reduction of toxicity, mobility, and volume through treatment, highest to lowest, is 4, 5, 3, 8, 2, 1. The overall ranking of the C-720 Northeast and Southeast Site alternatives with respect to reduction of toxicity, mobility, and volume through treatment, highest to lowest, is 5, 7, 6, 2, 1.

Alternative 4 would most likely accomplish the greatest reduction of toxicity, mobility, and volume at the Oil Landfarm using LDA excavation and *in situ* treatment of the “buffer zone.” The excavation process would be designed to remove 100% of the contamination present above the “buffer zone.” Alternative 5 would also result in a significant reduction in toxicity, mobility, and volume with an estimated treatment efficiency of 98%. Alternative 3 would accomplish less reduction of VOC mass than Alternatives 4 or 5, with an estimated treatment efficiency of 91%; however, the reduction in VOC mobility would be significant. The estimated treatment efficiency of Alternative 8 is 60% at the Oil Landfarm. Neither Alternative 1 nor 2 would implement active treatment, and reductions in concentrations would only occur through natural processes.

At the C-720 Northeast and Southeast Sites Alternative 5 would accomplish the greatest reduction of toxicity, mobility, and volume using the *in situ* ERH process. A treatment efficiency of 98% was estimated for Alternative 5 at the C-720 Northeast and Southeast Sites. Alternative 7 would also result in



a significant reduction in toxicity, mobility, and volume with an estimated treatment efficiency of 95%. Alternative 6 would accomplish less reduction of VOC mass than Alternatives 5 or 7, with an estimated treatment efficiency of 90%. Neither Alternative 1 nor 2 would implement active treatment, and reductions in concentrations would occur only through natural processes.

### 5.2.3 Short-Term Effectiveness

No added risks to the public or the environment would result from implementing any of the alternatives (risks to off-site residents would be controlled through the use of interim LUCs until the remedial action is implemented); therefore, only worker risks during remedy implementation and the time required to meet soil RGs are considered in this evaluation. All worker risks and hazards could be mitigated by worker protection programs, which would increase the cost and complexity of the alternatives. The E/PP program would protect workers until final disposition through the Soils OU.

The overall ranking of Oil Landfarm alternatives with respect to short-term effectiveness, highest to lowest, is 3, 5, 4, 8, 2, 1. The overall ranking of the C-720 Northeast and Southeast Site alternatives with respect to short-term effectiveness, highest to lowest, is 5, 7, 6, 2, 1.

Alternative 3 would provide the highest short-term effectiveness for the Oil Landfarm. Although the potential for worker exposure during the soil mixing process exists, the *in situ* nature of the treatment coupled with a relatively short duration until groundwater protection RGs would be met, provides high short term efficiency. In addition, the soil mixing process is estimated to take approximately 4 months of active remediation, less than that required for Alternatives 4, 5, or 8. Alternative 5 would rank behind Alternative 3. Although the time until VOC RGs would be attained is less than Alternative 3, the worker exposure risks are greater. Worker exposure risks would exist while drilling and installing electrode/vapor recovery wells in contaminated soil areas, and also would result in thermal and electrical hazards. The associated increase in requirements for safety analysis, hazard identification and control would result in increased complexity and cost for implementation; however, all of these issues were successfully resolved for the C-400 ERH Treatability Study. The short-term efficiency of Alternative 4 ranks behind Alternatives 3 and 5. The *ex situ* waste management, characterization, and disposal included in Alternative 4, pose significant health and safety challenges associated with the potential for worker exposure to contaminated media. Although minimal potential for worker exposures to contaminated media exist during implementation of Alternatives 8 and 2, these alternatives provide the least short-term efficiency due to the significant amount of time required to attain groundwater protection RGs (93 years and greater than 100 years, respectively).

At the C-720 Northeast and Southeast Sites, Alternatives 5 and 7 would provide the highest short-term effectiveness. Although the potential for worker exposure exists during the ERH and multiphase extraction processes, the relatively short durations until groundwater protection RGs would be met provides high short term efficiency (20 years and 39 years, respectively). Worker exposure risks associated with implementation of Alternative 5 would include those described in the previous paragraph for the Oil Landfarm. Alternative 7 would result in worker chemical exposure risks during multiphase and groundwater monitoring well installation, requiring on-site industrial hygienist coverage during drilling, in addition to appropriate monitoring, PPE, and procedures. Alternative 6 ranks behind Alternatives 5 and 7 due to the length of time required for VOC concentrations to meet groundwater protection RGs (approximately 52 years). The LAI process most likely would pose less health and safety exposure risks than Alternatives 5 or 7 due to the minimal amount of time required for active remediation (approximately 1 month). Although minimal potential for worker exposures to contaminated media exist during implementation of Alternative 2, this alternative provides the least short-term efficiency due to the significant amount of time required to attain groundwater protection RGs (approximately 97 years).

Alternative 1 has the lowest short-term effectiveness, because it would require the longest time for attainment of RGs.

#### **5.2.4 Implementability**

The ease or difficulty of implementing each of the alternatives was assessed in Section 4. The overall ranking of Oil Landfarm alternatives with respect to implementability, highest to lowest, is 1, 2, 8, 3, 5, 4. The overall ranking of the C-720 Northeast and Southeast Site alternatives with respect to implementability, highest to lowest, is 1, 2, 6, 7, 5.

Alternative 1 would be the most readily implementable alternative, because no action would be taken. Alternative 2 ranks high in implementability as well, because no active treatment is included.

For the Oil Landfarm, Alternative 8 ranks the next highest after Alternative 2. Alternative 8 requires installation of a trench and injection wells within the boundaries of the source area; however, Alternative 8 uses readily available industry equipment and services and is less intrusive or worker intensive than Alternatives 3, 4, or 5. Alternative 3 ranks behind Alternatives 1, 2, or 8, but ranks higher in implementability than Alternatives 4 or 5. The amount of *ex situ* waste management required during Alternative 3 is significantly less than Alternatives 4 or 5, and the amount of time required to implement deep soil mixing is less than Alternatives 4 or 5. Implementability of Alternative 4 is relatively low due to the worker protection issues discussed previously under short-term effectiveness. Implementability constraints for Alternative 5 would include the technical complexity of the alternative, relatively few vendors offering the technology, and the worker protection issues discussed previously under short-term effectiveness; however, these constraints were resolved for the C-400 ERH Treatability Study. No O&M would be required after completion of the ERH treatment; however, long-term groundwater monitoring and five-year reviews would be required as long as VOC concentrations in soil remained above RGs.

For the C-720 Northeast and Southeast Sites, Alternative 6 ranks the highest in implementability after Alternatives 1 and 2. The ability to implement this alternative within a highly industrialized area is greater than with Alternatives 5 or 7. No wells would require installation within the boundaries of the source areas, and the duration of active treatment (approximately 1 month) is less than the time required for Alternatives 5 or 7. An implementability constraint associated with the LAI process is that relatively few vendors offer this technology (or equivalent). Implementability constraints for Alternative 5 are the same as those described above for the Oil Landfarm. Alternative 7 could be implemented using readily available industry equipment and services; however, the longer period of O&M relative to Alternatives 6 or 5 reduces the overall implementability. Treatment of off-gas and co-produced groundwater, and soil vapor and soil moisture monitoring would be required for the estimated 2 year duration of operation.

#### **5.2.5 Cost**

A summary of the total project costs for each alternative are provided in Table 5.1. The overall ranking of Oil Landfarm alternatives with respect to cost, highest to lowest, is 1, 2, 8, 3, 4, 5. The overall ranking of the C-720 Northeast and Southeast Site alternatives with respect to cost, highest to lowest, is 1, 2, 7, 6.

### **5.3 SUMMARY OF THE COMPARATIVE ANALYSIS OF ALTERNATIVES**

The relative rankings of the alternatives with respect to the evaluation criteria are summarized in Table ES.3. The comparative analysis presented in Section 5 identifies the relative advantages and disadvantages of each alternative, so that the key tradeoffs that risk managers must balance can be identified. The comparative analysis provides a measure of the relative performance of the alternatives

**Table 5.1. Summary of Alternative Costs (Total Escalated Values)**

<b>Alternative*</b>	<b>C-720 Northeast Site (\$M)</b>	<b>C-720 Southeast Site (\$M)</b>	<b>Oil Landfarm (\$M)</b>
<b>Alternative 1</b> —No further action	\$0	\$0	\$0
<b>Alternative 2</b> —Long-term monitoring	\$2.2	\$2.2	\$2.2
<b>Alternative 3</b> — <i>In situ</i> source treatment using deep soil mixing	\$0	\$0	\$9.7
<b>Alternative 4</b> —Source removal and <i>in situ</i> chemical source treatment	\$0	\$0	\$12.1
<b>Alternative 5</b> — <i>In situ</i> thermal source treatment	\$7.1	\$7.1	\$17.2
<b>Alternative 6</b> — <i>In situ</i> source treatment using LAI	\$3.8	\$3.8	\$0
<b>Alternative 7</b> — <i>In situ</i> soil flushing and source treatment using multiphase extraction	\$4.4	\$4.4	\$0
<b>Alternative 8</b> — <i>In situ</i> source treatment using EISB	\$0	\$0	\$6.1

\*Alternatives 2 through 8 include use of interim LUCs.  
n/a = not applicable

against each evaluation criterion. With the exception of no further action, all alternatives would include implementation of interim LUCs maintained until final remedy selection as part of subsequent OUs that would address the relevant media. Five-year reviews would be required to document progress and would be required as long as concentrations of contaminants in soil remained above RGs.

For the Oil Landfarm Site, the evaluation of alternative effectiveness is significantly driven by the fact that the half-life of TCE is a controlling factor in the speed of groundwater remediation. As demonstrated by Table 4.4, the time to reach RGs is more-greatly affected by the half-life estimation than by the relative effectiveness of the competing alternatives. For example, none of the alternatives for the Oil Landfarm will meet groundwater protection RGs in less than 38 years with an assumed TCE degradation half-life of 25 years. All but Alternative 2 will meet groundwater protection RGs in less than 38 years with an assumed TCE degradation half-life of 5 years. Thus, the relative difference in effectiveness between alternatives will not have a major impact on time to achieve the groundwater MCL for the VOC concentrations estimated to be present at the Oil Landfarm relative to the time it will take for the RGA groundwater beneath the PGDP Site to meet MCLs at all locations

Overall, for the Oil Landfarm, Alternative 8 offers the least costly solution with higher programmatic risk and more uncertainty potentially associated with site conditions, implementation, and overall effectiveness. The delivery mechanisms associated with Alternative 8 are designed to limit, to the extent possible, the project risk associated with the potentially unfavorable conditions at the Oil Landfarm. Sufficient quantities of bioamendment would be introduced into the subsurface to overcome the natural aerobic conditions of the formation; the addition of a saturated bioamendment solution at several depth intervals is designed to provide an engineered solution to the variably unsaturated conditions of the formation; the horizontal trench and “herring-bone” pipelines essentially provide an engineered solution to the heterogeneity of the formation by allowing the bioamendment to follow similar migration pathways as the DNAPL; and a lactate reductant potentially could be utilized to more efficiently imitate the DNAPL and follow similar migration pathways.

Alternative 3 poses less programmatic risk and uncertainty, but at a higher cost. Active remediation associated with Alternative 3 most likely would be completed in approximately four months

Approximately two years of active remediation would be associated with Alternative 8. In total, the impacts of these uncertainties are small relative to the impacts of the half-life determination on the relative ranking of the alternatives. Based on a 25-year half-life, Alternative 8 would achieve groundwater protection RGs in approximately 93 years (compare to 35 years based on a 5-year half-life); Alternative 3 would achieve groundwater protection RGs in approximately 68 years (compare to 25 years based on a 5-year half-life).

A limited RDSI would be performed to confirm the VOC source mass and concentration extent. The concentration profile confirmed in the RDSI would be used with the modeling performed in this FFS to optimize the implementation of the selected alternative. As the VOC source mass decreases, the relative effectiveness of Alternative 8 increases as the lower residual concentrations reduce the time to achieve RGs.

For the C-720 Northeast and Southeast Sites, Alternative 7 offers the highest effectiveness and implementability at relatively moderate cost. Alternative 7 would involve approximately two years of treatment system operation. Alternative 7 utilizes well understood technologies that have been proven at many sites with similar characteristics. An RDSI would be performed to confirm the VOC source mass estimate and bound the treatment area. The concentration profile confirmed in the RDSI would be used with the modeling performed in this FFS to confirm the suitability of the selected alternative.

**THIS PAGE INTENTIONALLY LEFT BLANK**

## 6. REFERENCES

- Abriola, L. M. and S. A. Bradford 1998 "Experimental Investigations of the Entrapment and Persistence of Organic Liquid Contaminants in the Subsurface Environment," *Environmental Health Perspectives*, Volume 106, Supplement 4, August.
- AFCEE 2000, "Remediation of Chlorinated Solvent Contamination on Industrial and Airfield Sites," Air Force Center for Environmental Excellence, 2000, U.S. Air Force Environmental Restoration Program.
- ARS 2009, ARS Pneumatic Fracturing and Injection Field Services, accessed at [http://www.arstechnologies.com/pneumatic\\_fracturing.html](http://www.arstechnologies.com/pneumatic_fracturing.html).
- BJC 2006. *Cultural Resources Management Plan for the Paducah Gaseous Diffusion Plant, Paducah, Kentucky*, BJC/PAD-691/R1, March.
- Butler *et al.* 2000. "Direct-push Hydraulic Profiling in an Unconsolidated Alluvial Aquifer," James J. Butler, Jr., Alyssa A. Lanier, John M. Healey, and Stephen M. Sellwood Kansas Geological Survey, University of Kansas, and Wesley McCall and Elizabeth Garnett Geoprobe Systems, Inc., KGS Open File Report 2000-62 presentation by Lanier *et al.*, at the Geological Society of America Annual Meeting and Exposition, Reno, NV, November 14.
- Cal/EPA 1994. *Intermedia Transfer Factors for Contaminants Found at Hazardous Waste Sites, Trichloroethene*, Risk Science Program, Department of Environmental Toxicology University of California, Davis, CA, prepared for The Office of Scientific Affairs, The Department of Toxic Substances Control and the California Environmental Protection Agency in Support of the Cal TOX model, December.
- CDM 1994. *Investigation of Sensitive Ecological Resources Inside the Paducah Gaseous Diffusion Plant, Paducah, Kentucky*, Doc. No. 716-003-FR-BBRY, Paducah, KY, August 19.
- CH2M HILL 1991. *Results of the Site Investigation, Phase I, at the Paducah Gaseous Diffusion Plant, Paducah, Kentucky*, KY/ER-4, CH2M HILL, Southeast, Inc., Oak Ridge, TN, March.
- CH2M HILL 1992. *Results of the Site Investigation, Phase II, at the Paducah Gaseous Diffusion Plant, Paducah, Kentucky*, KY/SUB/13B-97777CP-03/1991/1, April.
- CH2M HILL NDA. *Results from Two Pilot Tests Using Pneumatic Fracturing and Chemical Oxidant Injection Technologies*, prepared by Thomas Palai, CH2M HILL, Denver, CO, and Craig L. Sprinkle, Atlanta, GA.
- Clausen, J. L. *et al.* 1997, *Evaluation of Natural Attenuation Processes for Trichloroethylene and Technetium-99 in the Northeast and Northwest Plumes at the Paducah Gaseous Diffusion Plant, Paducah, KY*, KY/EM-113, November 1997.
- COE (U.S. Army Corps of Engineers) 1994. *Environmental Investigations at the Paducah Gaseous Diffusion Plant and Surrounding Area, McCracken County, Kentucky*, Volumes 1-5, United States Army Corps of Engineers, Nashville, TN, May.

- COE 1995. U.S. Army Corps of Engineers, Louisville District, Louisville, KY, letter from Ronny J. Sadri, Project Manager, to Jimmie C. Hodges, Site Manager, U.S. Department of Energy, Paducah, KY, December 14.
- Deuren, J. V., T. Lloyd, S. Chhetry, R. Liou, and J. Peck 2002. *Remediation Technologies Screening Matrix and Reference Guide*, 4<sup>th</sup> Edition, United States Army Environmental Center, SFIM-AEC-ET-CR-97053, January.
- DOD (U.S. Department of Defense) 2007. *Field Demonstration and Validation of a New Device for Measuring Water and Solute Fluxes*, ESTCP Cost and Performance Report ER-0114, Environmental Security Technology Certification Program, U.S. Department of Defense, April.
- DOE (U.S. Department of Energy) 1994. *Secretarial Policy on the National Environmental Policy Act*, U.S. Department of Energy, June.
- DOE 1996a. *Feasibility Study for the Waste Area Group 23 and Solid Waste Management Unit 1 of Waste Area Group 27 at the Paducah Gaseous Diffusion Plant, Paducah, Kentucky*, DOE/OR/06-1423&D2, U.S. Department of Energy, Paducah, KY.
- DOE 1996b. "In Situ Enhanced Soil Mixing," Innovative Technology Summary Report, U.S. Department of Energy, Office of Environmental Management, Office of Science and Technology, DOE/EM-0289, February.
- DOE 1997. *Data Summary and Interpretation Report for Interim Remedial Design at Solid Waste Management Unit 2 of Waste Area Grouping 22 at the Paducah Gaseous Diffusion Plant, Paducah, Kentucky*, DOE/OR/07-1549&D1, U.S. Department of Energy, Paducah, KY, February.
- DOE 1998a. *Final Remedial Action Report for Waste Area Grouping (WAG) 23 and Solid Waste Management Unit 1 of WAG 27 at the Paducah Gaseous Diffusion Plant, Paducah, Kentucky*, DOE/OR/07-1737&D0, Primary Document, U.S. Department of Energy, Paducah, KY, June.
- DOE 1998b. *Record of Decision for Remedial Action at Solid Waste Management Unit 91 of Waste Area Group 27 at the Paducah Gaseous Diffusion Plant, Paducah, Kentucky*, December.
- DOE 1999a. *Remedial Investigation Report for Waste Area Grouping 27 at the Paducah Gaseous Diffusion Plant, Paducah, Kentucky*, DOE/OR/07-1777&D2, U.S. Department of Energy, Paducah, KY, June.
- DOE 1999b. *Remedial Investigation Report for Waste Area Grouping 6 at the Paducah Gaseous Diffusion Plant, Paducah, Kentucky*, DOE/OR-07-1727&D2, U.S. Department of Energy, Paducah, KY, May.
- DOE 1999c. *Bench Scale In-Situ Chemical Oxidation Studies of Trichloroethene in Waste Area Grouping 6 at the Paducah Gaseous Diffusion Plant, Paducah, Kentucky*, DOE/OR/07-1788&D1, Secondary Document, February.
- DOE 2000a. *Remedial Investigation Report for Waste Area Grouping 3 at the Paducah Gaseous Diffusion Plant, Paducah, Kentucky*, DOE/OR/07-1895&D1, U.S. Department of Energy, Paducah, KY, September.

- DOE 2000b. *Data Report for the Sitewide Remedial Evaluation for Source Areas Contributing to Off-Site Groundwater Contamination at the Paducah Gaseous Diffusion Plant, Paducah, Kentucky*, DOE/OR/07-1845/D1, U.S. Department of Energy, January. (also known as Data Gaps document).
- DOE 2000c. *Innovative Technology Summary Report, In situ Redox Manipulation*, Subsurface Contaminants Focus Area, DOE/EM-99, January.
- DOE 2001a. *Methods for Conducting Risk Assessments and Risk Evaluations at the Paducah Gaseous Diffusion Plant, Paducah, Kentucky, Volume I. Human Health and Volume II. Ecological*, DOE/OR/07-1506&D2/V1&V2/R0, U.S. Department of Energy, Paducah, KY, December.
- DOE 2001b. *Feasibility Study for the Groundwater Operable Unit at Paducah Gaseous Diffusion Plant, Paducah, Kentucky*, DOE/OR/07-1857&D2, U.S. Department of Energy, Paducah, Kentucky, August.
- DOE 2002a. *Final Remedial Action Report for Lasagna Phase IIB In situ Remediation of Solid Waste Management Unit 91 at the Paducah Gaseous Diffusion Plant, Paducah, Kentucky*, DOE/OR/07-2037&D1, September.
- DOE 2002b. *Final Technical Report Research and Development EarthSaw<sup>TM</sup> In situ Containment of Pits and Trenches*, U.S. Department of Energy Technology Laboratory, September.
- DOE 2003. *Final Report, Six-Phase Heating Treatability Study at the Paducah Gaseous Diffusion Plant, Paducah, Kentucky*, DOE/OR/07-2113&D1, Secondary Document, U.S. Department of Energy, Paducah, KY, December.
- DOE 2004. *Work Plan for the Southwest Plume at the Paducah Gaseous Diffusion Plant, Paducah, Kentucky*, DOE/OR/07-2094&D2, U.S. Department of Energy, Paducah, KY, February.
- DOE 2007. *Site Investigation Report for the Southwest Groundwater Plume at the Paducah Gaseous Diffusion Plant, Paducah, Kentucky*, DOE/OR/07-2180&D2/R1, U.S. Department of Energy, Paducah, KY, June.
- DOE 2008. *Land Use Control Implementation Plan: Interim Remedial Action for the Groundwater Operable Unit for the Volatile Organic Compound Contamination at the C-400 Cleaning Building at the Paducah Gaseous Diffusion Plant, Paducah, Kentucky*, DOE/OR/07-2151&D2/R2, February.
- DOE 2010a. *Focused Feasibility Study for the Southwest Groundwater Plume Volatile Organic Compound Sources (Oil Landfarm and C-720 Northeast and Southeast Sites) at the Paducah Gaseous Diffusion Plant, Paducah, Kentucky*, DOE/LX/07-0186&D2/R2, U.S. Department of Energy, Paducah, KY, July.
- DOE 2010b. *Site Management Plan, Paducah Gaseous Diffusion Plant, Paducah, Kentucky, Annual Revision-FY 2010*.
- DOE 2010c. *Methods for Conducting Risk Assessments and Risk Evaluations at the Paducah Gaseous Diffusion Plant, Paducah, Kentucky*, DOE/LX/07-0107&D1/V1, U.S. Department of Energy, Paducah, KY, July.



- Dwyer, B. P. 1994. "Feasibility of Permeation Grouting for Constructing Subsurface Barriers," SAND94-0786, Sandia National Laboratories, April.
- EPA (U.S. Environmental Protection Agency) 1986, *Guidelines for Ground-Water Classification Under the EPA Ground-Water Protection Strategy*, U. S. Environmental Protection Agency, November.
- EPA 1987. *Design, Construction and Maintenance of Covers Systems for Hazardous Waste, An Engineering Guidance Document*, EPA/600/2-87/039, NTIS PB 87-191656, U.S. Environmental Protection Agency, May.
- EPA 1988. *Guidance for Conducting Remedial Investigations and Feasibility Studies Under CERCLA*, EPA/540/G-89/004, U.S. Environmental Protection Agency, Office of Emergency and Remedial Response, Washington, DC, October.
- EPA 1996. *Presumptive Response Strategy and Ex Situ Treatment Technologies for Contaminated Groundwater at CERCLA Sites, Final Guidance*, U.S. Environmental Protection Agency, EPA/540/R-96/023, October.
- EPA 1998a. *Federal Facility Agreement for the Paducah Gaseous Diffusion Plant*, U.S. Environmental Protection Agency, Region 4, Atlanta, GA, February 13.
- EPA 1998b. *Technical Protocol for Evaluating Natural Attenuation of Chlorinated Solvents in Groundwater*, EPA/600/R-98/128, U.S. Environmental Protection Agency, Washington DC, September.
- EPA 1999a. "Subsurface Containment and Monitoring Systems: Barriers and Beyond (Overview Report)," U.S. Environmental Protection Agency Office of Solid Waste and Emergency Response, Technology Innovation Office, Washington, DC, March. Accessed at <http://www.clu-in.org>.
- EPA 1999b. *Monitored Natural Attenuation of Chlorinated Solvents*, U.S. Environmental Protection Agency, EPA/600/F-98/022, May.
- EPA 2003. "Site Technology Capsule: MatCon Modified Asphalt for Waste Containment," EPA/540/R-03/505A, U.S. Environmental Protection Agency, June.
- EPA 2004a. *Handbook of Groundwater Protection and Cleanup Policies for RCRA Corrective Action*, EPA/530/R-04/030, Office of Solid Waste and Emergency Response, Washington, DC, April.
- EPA 2004b. *How to Evaluate Alternative Cleanup Technologies for Underground Storage Tanks Sites*, EPA/510-R-04-002, Solid Waste and Emergency Response, May.
- EPA 2005. *Steam Enhanced Remediation Research for DNAPL in Fractured Rock*, Loring Air Force Base, Limestone, ME, U.S. Environmental Protection Agency, Office of Research and Development, Cincinnati, OH, August.
- EPA 2006. *Off-Gas Treatment Technologies for Soil Vapor Extraction Systems: State of the Practice*, EPA-542-R-05-028, Office of Superfund Remediation and Technology Innovation, Office of Solid Waste and Emergency Response, March.

- EPA 2007. *Presumptive Remedies: Policy and Procedures*, U.S. Environmental Protection Agency, last updated on Tuesday, July 17, 2007, Accessed July 14, 2008, at <http://www.epa.gov/superfund/policy/remedy/presump/pol.htm>.
- EPA 2008a. "Resolution of the Environmental Protection Agency Letter of Non-Concurrence for the Site Investigation Report for the Southwest Plume at the Paducah Gaseous Diffusion Plant, Paducah, Kentucky (DOE/OR/07-2180&D2) and Notice of Informal Dispute Dated November 30, 2007, McCracken County, Kentucky KY 8-890-008-982."
- EPA CLU-IN 2008. "Contaminant Focus: DNAPLs," Accessed at [http://www.clu-in.org/contaminantfocus/default.focus/sec/Dense\\_Nonaqueous\\_Phase\\_Liquids\\_\(DNAPLs\)/cat/Treatment\\_Technologies/p/5](http://www.clu-in.org/contaminantfocus/default.focus/sec/Dense_Nonaqueous_Phase_Liquids_(DNAPLs)/cat/Treatment_Technologies/p/5).
- EPA 2010. *Memorandum of Agreement for Resolution of Informal Dispute for the Focused Feasibility Study for the Southwest Plume Volatile Organic Compound Sources Oil Landfarm and C-720 Northeast and Southeast Sites) at the Paducah Gaseous Diffusion Plant, Paducah, KY, DOE/LX/07-0186&D2*, May 20.
- FRTR 2008. *Remediation Technologies Screening Matrix and Reference Guide*, Version 4.0, Federal Remediation Technologies Roundtable at [http://www.frtr.gov/matrix2/top\\_page.html](http://www.frtr.gov/matrix2/top_page.html).
- GSI 2004. "Final Report for Full-Scale Mulch Wall Treatment of Chlorinated Hydrocarbon-Impacted Groundwater," Offutt Air Force Base, Nebraska, Building 301, prepared for Air Force Center for Environmental Excellence, Brooks City-Base, TX, April 13. Accessed at <http://www.dtic.mil/cgi-bin/GetTRDoc?AD=ADA422621&Location=U2&doc=GetTRDoc.pdf>.
- Hightower, *et al.* 2001. *Innovative Treatment and Remediation Demonstration*, Paducah Groundwater Project Innovative Technology Review, March.
- ISF (*In situ* Fixation, Inc.) Accessed September 2008, at <http://www.insitufixation.com/services/index.shtml>.
- IRTC (Interstate Technology Regulatory Council) 2002. *Passive Diffusion Bag (PDB) Samplers*, Frequently Asked Questions, February.
- ITRC 2005. *Overview of In Situ Bioremediation of Chlorinated Ethene DNAPL Source Zones*, Interstate Technology & Regulatory Council, Bioremediation of DNAPLs Team, 444 North Capitol Street, Northwest, Suite 445, Washington, DC 20001, October 2005. Accessed at <http://www.itrcweb.org/Documents/BioDNAPL-1.pdf>.
- Jacobs EM Team, 1997. *Groundwater Conceptual Model for the Paducah Gaseous Diffusion Plant, Paducah, Kentucky*, DOE/OR/06-1628&D0, Jacobs EM Team, Kevil, Kentucky, August.
- Jacobs, J. A. and Testa S. M. 2003. *Design Considerations for In Situ Chemical Oxidation Using High Pressure Jetting Technology*, [http://www.ebsinfo.com/chemical\\_oxidation.pdf](http://www.ebsinfo.com/chemical_oxidation.pdf), preprint for an article to be featured in Association for Environmental Health and Science, April.
- Johnson, P. C. and R. A. Ettinger 1991. "Heuristic Model for Predicting the Intrusion Rate of Contaminant Vapors into Buildings," *Environmental Science and Technology*, 25, 1445-1452.

- KDAQ (Kentucky Division of Air Quality) 2008. *Fiscal Year 2008 Annual Report*, Kentucky Division for Air Quality, Frankfort, KY.
- Kram, M. L., A. Keller, J. Rossabi, and L. Everett 2001. *DNAPL Characterization Methods and Approaches, Part 1: Performance Comparisons*, Groundwater Monitoring Review, Fall.
- KRCEE (Kentucky Research Consortium for Energy and Environment) 2005, *Evaluation of Groundwater Management/Remediation Technologies for Application to the Paducah Gaseous Diffusion Plant*, UK/KRCEE Doc #: P7.1 2005, KRCEE, September.
- KRCEE 2008. *PGDP Trichloroethene Biodegradation Investigation Summary Report, Regional Gravel Aquifer & Northwest Plume*, prepared by TCE Fate and Transport Project Team through University of Kentucky Research Consortium for Energy and Environment, September.
- KSNPC 1991. *Biological Inventory of the Jackson Purchase Region*, Kentucky State Nature Preserves Commission, Frankfort, KY.
- LMES (Lockheed Martin Energy Systems) 1997. *Evaluation of Natural Attenuation Processes for Trichloroethylene and Technetium-99 in the Northeast and Northwest Plumes at the Paducah Gaseous Diffusion Plant, Paducah, Kentucky*, KY/EM-113.
- McMillan-McGee Corp., 2009. *ET-DSP™ Technical Description*, accessed at: <http://www.mcmillan-mcgee.com/mcmillan-mcgee/papers/ETDSP-Technical-Description.pdf>.
- MK Corporation 1999. "Summary of Estimated Costs for Ozone Sparging Using the C-Sparge Process, Paducah ITRD Project, Paducah, KY," [http://www.nwer.sandia.gov/itrd/Cost/c\\_sparge.pdf](http://www.nwer.sandia.gov/itrd/Cost/c_sparge.pdf).
- MMES (Martin Marietta Energy Systems) 1992. *Report of the Paducah Gaseous Diffusion Plant Groundwater Investigation Phase III*, KY/E-150, Martin Marietta Energy Systems, Inc., Paducah, KY, November.
- NOAA (National Oceanic and Atmospheric Administration) 2004. *NOAA Atlas 14: Precipitation-Frequency Atlas of the United States, Volume 2*, Version 3.0. National Oceanic and Atmospheric Administration, Silver Spring, MD.
- NRC (National Research Council) 2004. "Contaminants in the Subsurface, Source Zone Assessment and Remediation," National Research Council of the National Academies, National Academies Press, Washington, DC.
- OCETA (Ontario Centre for Environmental Technology Advancement) 2003. "Pressure Pulse Technology (PPT) for Recovery of Nonaqueous Phase Liquids," *OCETA Environmental Technology Profiles*, available at [http://www.oceta.on.ca/profiles/Wavefront/PPT\\_tech.html](http://www.oceta.on.ca/profiles/Wavefront/PPT_tech.html). Accessed September 25, 2008.
- OMB 2009, OMB Circular No. A-94, "Guidelines and Discount Rates for Benefit-Cost Analysis of Federal Programs 2010 Discount Rates of OMB, Circular No. A-94," Office of Management and Budget, Washington D.C., December 2009.
- Payne, F. C., J. A. Quinnan, and S. T. Potter 2008. *Remediation Hydraulics*, CRC Press, Boca Raton, FL.

- Pettit, P. J., D. E. Ridenour, D. Harris, and J. Jalovec 1996. "Success in Horizontal Barrier Developments," FEMP-2491, CONF-960212-92, U.S. Department of Energy, Fernald Environmental Management Project, Presented at Waste Management 1996, Tucson, AZ, February 25-29.
- PRS (Paducah Remediation Services, LLC) 2007. *Transportation Safety Document for On-Site Transport within the Paducah Gaseous Diffusion Plant Paducah, Kentucky*, PRS-WSD-0661, Paducah Remediation Services, LLC, Paducah, KY.
- Riha, B, J. Rossabi, C. Eddy-Dilek, and D. Jackson 1999. *DNAPL Characterization Using the Ribbon NAPL Sampler: Methods and Results*, Westinghouse Savannah River Company, Aiken, SC, December. [http://www.osti.gov/bridge/product.biblio.jsp?query\\_id=0&page=0&osti\\_id=15027](http://www.osti.gov/bridge/product.biblio.jsp?query_id=0&page=0&osti_id=15027).
- Sale, T., M. Petersen, and D. Gilbert 2005. "Final Report Electrically Induced Redox Barriers for Treatment of Groundwater," prepared for Environmental Security Technology Certification Program, March 2005.
- Sorenson, K. S., Jr., L. N. Peterson, R. L. Ely, and R. E. Hinchee 2000. *An Evaluation of Aerobic Trichloroethene Attenuation Using First-Order Rate Estimation*, Appendix E of the "Field Demonstration Report, Test Area North Final Groundwater Remediation, Operable Unit 1-07B" (DOE/ID-10718), Idaho National Engineering and Environmental Laboratory, March 27.
- TCT-St. Louis 1991. *Phase I Remedial Investigation at the Former Kentucky Ordnance Works, McCracken County, Kentucky*, 1321K.920818.006, U.S. Army Corps of Engineers, Nashville District, Nashville, TN, November.
- Terzaghi, K. T, R. B. Peck, and G. Mesri, 1996. *Soil Mechanics in Engineering Practice*, Third Edition, John Wiley & Sons, Inc., New York, NY.
- Tri-Agency 2002. "Evaluation of Permeable Reactive Barrier Performance," prepared for the Federal Remediation Technologies Roundtable (FRTR) by the Tri-Agency Permeable Reactive Barrier Initiative- Members: U.S. Department of Defense, U.S. Department of Energy, U.S. Environmental Protection Agency, and Interstate Technology and Regulatory Council, December 9.
- USDA (U.S. Department of Agriculture) 1976. *Soil Survey of Ballard and McCracken Counties, Kentucky*, USDA Soil Conservation Service and Kentucky Agricultural Experiment Station.

**THIS PAGE INTENTIONALLY LEFT BLANK**

## **APPENDIX A**

### **EVALUATION OF TECHNOLOGIES AND PROCESS OPTIONS**

**THIS PAGE INTENTIONALLY LEFT BLANK**

**Table A.1. Oil Landfarm and the C-720 Northeast and Southeast Sites Technology Screening**

<b>General Response Action</b>	<b>Technology Type</b>	<b>Process Options</b>	<b>Description</b>	<b>Technology Status</b>	<b>Screening Comments</b>
<b>Land Use Controls</b>	Institutional controls	E/PP program	Requires review and approval of any proposed intrusive activities to protect workers and remedy integrity.	Available	Technically implementable
	Physical controls	Warning signs	Provide notification to worker to prevent unauthorized access.	Available	Technically implementable
<b>Monitoring</b>	Soil monitoring	Soil cores	Collection of soil cores and appropriate analyses can be used to monitor the decreases in TCE concentrations in source areas (including DNAPL) to ensure the rate of decrease matches that expected from technical analyses. Continuous soil cores may be obtained using DPT, hollow-stem auger, or other drilling methods and analyzed. DNAPL TCE may be detected using field “shake tests,” UV fluorescence, or dyes.	Commercially available	Technically implementable
		Membrane interface probe	MIP sampling can be used to assess reductions in VOC concentrations in soils. MIP sampling uses a heating element and gas permeable membrane. The element heats the material surrounding the probe, causing the VOCs contained in the material to vaporize. Vapors enter the probe through a gas permeable membrane and are transported through tubing to the surface by an inert carrier gas. The sample then is analyzed in the field with equipment appropriate to the needs of the investigation.	Commercially available	Technically implementable
		Soil vapor sampling	Soil vapor sampling may be used to monitor reductions in concentrations of VOCs in soil pore space and indirectly determine decreases in the extent of NAPL TCE. Drive points connected to plastic or stainless steel tubing are driven or pushed to the desired depth and soil vapor extracted and analyzed.	Commercially available	Technically implementable



**Table A.1. Southwest Plume Source Areas Technology Screening (Continued)**

<b>General Response Action</b>	<b>Technology Type</b>	<b>Process Options</b>	<b>Description</b>	<b>Technology Status</b>	<b>Screening Comments</b>
<b>Monitoring (continued)</b>	Soil monitoring (continued)	Soil moisture sampling	Soil moisture sampling using suction lysimeters may be used to determine pore water concentrations of VOCs. Porous cups attached to plastic tubing are installed in silica flour in drilled or driven boreholes. Vacuum is applied to tubing causing water to flow into the porous cup. The collected water is then analyzed on- or off-site.	Commercially available	Technically implementable
		Gore-sorbers	Passive soil gas samplers are used to characterize saturated and unsaturated zone VOC contamination.	Commercially available	Technically implementable
		Raman spectroscopy	Implemented using CPT. Raman spectroscopy relies on the detection of light wavelength shifts from compounds of interest and is capable of direct identification of several chlorinated DNAPL.	Commercially available	Technically implementable
	Groundwater monitoring	Sampling and analysis	Groundwater samples can be obtained from wells completed in saturated zone using pumps, bailers, or passive samplers. Analysis can be performed on-site using field instrumentation or off-site at fixed-base laboratories.	Commercially available	Technically implementable
		Partitioning interwell tracer test (PITT)	The PITT uses surfactant techniques to measure the volume and describe the spatial distribution of subsurface DNAPL contamination zones.	Commercially available	Low technical implementability
		Diffusion bags	Diffusion bags are passive groundwater sampling devices that can be hung in wells to collect VOCs or other soluble contaminants. Semipermeable diffusion bags containing deionized water are allowed to equilibrate with surrounding groundwater and eventually reach the same concentrations of soluble constituents. The bags are sent to the vendor for analysis.	Commercially available	Technically implementable

**Table A.1. Southwest Plume Source Areas Technology Screening (Continued)**

<b>General Response Action</b>	<b>Technology Type</b>	<b>Process Options</b>	<b>Description</b>	<b>Technology Status</b>	<b>Screening Comments</b>
<b>Monitoring (continued)</b>	Groundwater monitoring (continued)	Borehole fluxmeter	Groundwater flows through the PFM deployed in a well under natural gradient conditions. The interior composition of the PFM is a matrix of hydrophobic and hydrophilic permeable sorbents that retain dissolved organic and/or inorganic contaminants present in fluid intercepted by the unit. The sorbent matrix is also impregnated with known amounts of one or more fluid soluble resident tracers, which are leached from the sorbent at rates proportional to fluid flux.	Innovative/emerging	Technically implementable
		Ribbon NAPL sampler	Direct sampling device that provides detailed depth discrete mapping of NAPLs in a borehole. The RNS has been deployed in the vadose and saturated zones.	Innovative/emerging	Technically implementable in UCRS only
		DNAPL interface probe	Direct sampling device that detects DNAPL-water interface in groundwater monitoring wells.	Commercially available	Technically implementable
<b>Monitored natural attenuation</b>	Monitoring and natural processes	Soil and groundwater monitoring; abiotic and biological processes	Natural processes including dilution, diffusion, dispersion, sorption, biodegradation, combined with monitoring.	Commercially available	Technically implementable
<b>Removal</b>	Excavators	Backhoes, trackhoes	Tracked excavators with conventional 13.7-m (45-ft) arms are limited to approximately 9.14 m (30 ft) bgs for soil removal.	Commercially available	Technically implementable
		Vacuum excavation, remote excavator	Commercial vacuum excavators may be used for potholing and excavation in environments where tracked excavators with operators would not be used based on health and safety considerations or other technical criteria..	Commercially available	Technically implementable
		Crane and clamshell	Used where excavation capability at depths greater than 30 ft is desired, and where large volumes of soil and debris are to be removed.	Commercially available	Technically implementable

**Table A.1. Southwest Plume Source Areas Technology Screening (Continued)**

<b>General Response Action</b>	<b>Technology Type</b>	<b>Process Options</b>	<b>Description</b>	<b>Technology Status</b>	<b>Screening Comments</b>
<b>Removal (Continued)</b>		Large diameter auger	Excavation at depths up to 90 ft bgs. Conventionally used for source removal where standard heavy equipment is not feasible	Commercially available	Technically implementable
<b>Containment</b>	Hydraulic containment	Recharge controls	Recharge controls can reduce facility discharges to the UCRS, promote surface water run-off, and reduce recharge of the UCRS in the Southwest Plume TCE source areas, thereby limiting leaching of TCE from NAPL source areas and migration to the RGA.	Implements best management practices and equipment/materials	Technically implementable
		Groundwater extraction	Groundwater pumping wells create a localized hydraulic gradient and corresponding cone of depression in the potentiometric surface, causing flow to the well and thereby a capture zone.	Commercially available	Suitable for extraction of dissolved-phase contamination in transmissive hydrologic environments (e.g. RGA). Yields of wells in the UCRS are too low to be technically implementable; retained only as a secondary technology for other treatments
	Surface barriers	RCRA Subtitle C cover	Multilayered cover incorporating compacted clay and geosynthetics, used for RCRA hazardous waste landfill closures.	Commercially available	Technically implementable
		Concrete-based cover	Concrete cover systems may consist of a single layer of concrete pavement over a prepared subgrade to isolate contaminated soils, reduce infiltration, and provide a trafficable surface.	Commercially available	Technically implementable
		Conventional asphalt cover	Asphalt cover systems may consist of a single layer of bituminous pavement over a prepared subgrade to isolate contaminated soils, reduce infiltration, and provide a trafficable surface. Must be sealed and/or combined with a low-permeability membrane to effectively reduce permeability.	Commercially available	Technically implementable

**Table A.1. Southwest Plume Source Areas Technology Screening (Continued)**

General Response Action	Technology Type	Process Options	Description	Technology Status	Screening Comments
Containment (Continued)		MatCon asphalt	MatCon™ asphalt has been used for RCRA Subtitle C-equivalent closures of landfills and soil contamination sites. MatCon™ is produced using a mixture of a proprietary binder and a specified aggregate in a conventional hot-mix asphalt plant.	Commercially available	Technically implementable
	Surface barriers (continued)	Flexible membrane	Single layers of low permeability polymeric plastic (HDPE and others) laid out in rolls or panels and welded together. The resulting membrane cover is essentially impermeable to transmission of water unless breached. Flexible membranes can be sealed around surface infrastructure using waterproof sealants.	Commercially available	Technically implementable
	Subsurface horizontal barriers	Freeze walls	Constructed by artificially freezing the soil pore water, resulting in decreased permeability and formation of a low-permeability barrier. The frozen soil restricts contaminant migration by reducing groundwater flow through the frozen soil matrix.	Commercially available	Technically implementable
		Jet grouting	Grouts are injected through drill rods to reduce infiltration of water. The jetted grout mixes with the soil form a column or panel.	Commercially available	No demonstrated technical implementability
		Permeation grouting	Low-viscosity grout is injected vertically or directionally at multiple locations into soil.	Commercially available	Not technically implementable. Establishing and verifying a continuous, effective subsurface barrier is difficult or impossible in heterogeneous and/or low-permeability soils or in the presence of subsurface infrastructure.

**Table A.1. Southwest Plume Source Areas Technology Screening (Continued)**

<b>General Response Action</b>	<b>Technology Type</b>	<b>Process Options</b>	<b>Description</b>	<b>Technology Status</b>	<b>Screening Comments</b>
<b>Containment (continued)</b>	Subsurface vertical barriers	Slurry walls	Vertically excavated trenches that are kept open backfilled with a slurry, generally bentonite and water. Soil (often excavated material) then is mixed with bentonite and water to create a low-permeability soil-bentonite backfill.	Commercially available	Technically implementable
	Subsurface vertical barriers (continued)	Sheet pilings	Long [e.g., 18.3 m (60 ft)] structural steel sections with a vertical interlocking system that are driven into the ground to create a continuous subsurface wall. After the sheet piles have been driven to the required depth, they are cut off at the surface. The subsurface soils must be relatively homogenous (i.e., no boulders) to allow for a uniform installation.	Commercially available	Technically implementable
		Permeable reactive barrier	Permeable reactive barriers (PRBs) are designed and constructed to permit the passage of water while immobilizing or destroying contaminants through the use of various reactive agents.	Commercially available	Technically implementable
<b>Treatment</b>	Biological	Anaerobic reductive dechlorination- <i>in situ</i>	ARD occurs when microbes utilize chloroethenes as terminal electron acceptors in metabolic processes. Saturated conditions are required.	Commercially available	Technically implementable
		Aerobic cooxidation- <i>in situ</i>	Aerobic cooxidation of TCE occurs when a microbe using a different organic compound as a carbon and energy source produces enzymes that fortuitously degrade a second compound without deriving energy or carbon for growth from that compound. Saturated conditions are required.	Commercially available	Technically implementable
		Phytoremediation- <i>in situ</i>	Phytoremediation exploits plant processes including transpiration and rhizosphere enzymatic activity to uptake water and dissolved-phase contaminants or to transform contaminants.	Commercially available	Not technically implementable due to depth of VOC contamination. Phytoremediation is limited to the surface area and depth occupied by the roots of the plants.

**Table A.1. Southwest Plume Source Areas Technology Screening (Continued)**

<b>General Response Action</b>	<b>Technology Type</b>	<b>Process Options</b>	<b>Description</b>	<b>Technology Status</b>	<b>Screening Comments</b>
<b>Treatment (continued)</b>	Physical/chemical	Soil vapor extraction- <i>in situ</i>	Removal of unsaturated zone air and vapor by applying vacuum.	Commercially available	Technically implementable
		Multiphase extraction- <i>in situ</i>	Application of high vacuum to pump various phases of contaminated groundwater, DNAPL, and vapor from the subsurface.	Commercially available	Technically implementable
	Physical/chemical (continued)	Air sparging- <i>in situ</i>	Promotes volatilization of VOCs in saturated zone by injecting air. Can be combined with SVE.	Commercially available	Technically implementable
		Soil flushing- <i>in situ</i>	Promotes dissolution or desorption of VOCs in soil, may mobilize NAPLs by reducing interfacial tension. Can be applied <i>in situ</i> or <i>ex situ</i> .	Commercially available	Technically implementable
		Electrokinetics- <i>in situ</i>	Applied <i>in situ</i> as Lasagna™ process.	Commercially available	Technically implementable
		Air stripping- <i>ex situ</i>	Applied <i>ex situ</i> for secondary waste treatment.	Commercially available	Technically implementable
		Ion exchange- <i>ex situ</i>	Applied <i>ex situ</i> for removal of cations or anions from aqueous secondary wastes.	Commercially available	Technically implementable
		Granular activated carbon- <i>ex situ</i>	Applied <i>ex situ</i> for secondary aqueous waste or off-gas treatment.	Commercially available	Technically implementable
		Vapor condensation- <i>in situ</i>	Applied <i>ex situ</i> for secondary waste off-gas treatment.	Commercial availability uncertain	Technical implementability uncertain
		Soil fracturing- <i>in situ</i>	Potential adjunct technology for some <i>in situ</i> treatment, containment, or removal technologies.	Commercially available	Technically implementable
		Soil mixing- <i>in situ</i>	Potential adjunct technology for some <i>in situ</i> treatment, containment, or removal technologies.	Commercially available	Technically implementable
Liquid atomized injection- <i>in situ</i>	A proprietary delivery mechanism that injects a reagent into the subsurface in an aerosolized state. Pneumatically fracture low permeability formations.	Commercially available	Technically implementable		
<b>Treatment</b>	Thermal	Catalytic oxidation- <i>ex situ</i>	Applied <i>ex situ</i> for secondary vapor treatment.	Commercially available	Technically implementable

**Table A.1. Southwest Plume Source Areas Technology Screening (Continued)**

General Response Action	Technology Type	Process Options	Description	Technology Status	Screening Comments
(continued)		Electrical resistance heating- <i>in situ</i>	Saturated or unsaturated soils are heated by applying current in subsurface, resulting in <i>in situ</i> steam stripping. VOCs and steam are recovered by SVE wells and treated. Can be implemented as 3-phase or 6-phase heating.	Commercially available	Technically implementable
		Thermal desorption- <i>ex situ</i>	Soils are heated to volatilize VOCs, which are then treated. Applied <i>ex situ</i> for excavated waste treatment.	Commercially available	Technically implementable
	Thermal (continued)	Steam stripping- <i>in situ</i>	<i>In situ</i> injection of steam.	Commercially available	Technically implementable
	Chemical	Permanganate- <i>in situ</i>	Injection of permanganate species in subsurface to oxidize VOCs.	Commercially available	Technically implementable. Does not act directly on NAPLs.
		Fenton's reagent- <i>in situ</i>	Injection of hydrogen peroxide and ferrous iron in subsurface to oxidize VOCs.	Commercially available	Technically implementable. Does not act directly on NAPLs.
		<i>ZVI-in situ</i>	Dechlorination of chloroethenes by elemental iron. Applied <i>in situ</i> as permeable reactive treatment zone or barrier.	Commercially available	Technically implementable
		Ozonation- <i>in situ</i>	Injection of ozone gas in saturated zone to oxidize VOCs.	Commercially available	Technically implementable. Does not act directly on NAPLs.
		Persulfate- <i>in situ</i>	Injection of sodium persulfate in soils to oxidize VOCs. Most effective when ferrous iron is added as a catalyst or when heated.	Commercially available	Technically implementable
	Redox manipulation- <i>in situ</i>	Dithionite injection, others to promote oxidation or reduction in saturated zone.	Commercially available	Technically implementable. Does not act directly on NAPLs.	

**Table A.1. Southwest Plume Source Areas Technology Screening (Continued)**

<b>General Response Action</b>	<b>Technology Type</b>	<b>Process Options</b>	<b>Descriptions</b>	<b>Technology Status</b>	<b>Screening Comments</b>
<b>Disposal</b>	Land disposal	Off-site or on-site permitted commercial disposal facility	Shallow land burial site for LLW, MLLW, and HW disposal option.	Commercially available	Technically implementable if WAC are met.
	Discharge to water	Discharge to groundwater	Discharges within area of contamination allowed under CERCLA after treatment.	Available on-site; injection wells required	Technically implementable
		Discharge to surface water	Discharges to existing permitted outfalls for treated liquid effluents.	Available on-site	Technically implementable



**Table A.2. Evaluation of Southwest Plume Source Area Process Options**

General Response Action	Technology Type	Process Option	Effectiveness			Implementability		Relative Cost	
			Long-term effectiveness	Short-term effectiveness	Demonstrated effectiveness and reliability	Technical	Administrative	Capital	O&M
Land Use Controls	Institutional controls	E/PP program	High-effective at preventing potential worker exposures for as long as necessary, if implemented appropriately	High-effective at preventing potential worker and off-site resident exposures	High	High	High	Low	Low
	Physical controls	Warning signs	Low-Effective at preventing exposures, but does not reduce contamination level	High-effective at preventing public and worker exposures	High	High	High	Low	Low
Monitoring	Soil monitoring	Soil cores	High-effective at determining total TCE concentrations for compliance monitoring - does not reduce contamination level	Moderate-less effective for determining DNAPL distribution	Moderate for locating DNAPL	High	High	Moderate – Dependent on requirements of monitoring plan	NA
Monitoring (Continued)		Membrane interface probe	Moderate-limited usefulness for compliance monitoring depending on cleanup level and monitoring plan requirements due to limits on detection	High-effective for assessing changes in NAPL distribution	Moderate	High	High	Low	NA

**Table A.2. Evaluation of Southwest Plume Source Area Process Options (Continued)**

General Response Action	Technology Type	Process Option	Effectiveness			Implementability		Relative Cost	
			Long-term effectiveness	Short-term effectiveness	Demonstrated effectiveness and reliability	Technical	Administrative	Capital	O&M
		Soil vapor sampling	High-effective in determining progress of remedy	High-effective for assessing changes in NAPL distribution	Moderate	High	High	Moderate	NA
		Soil moisture sampling	High-can measure actual TCE pore water concentrations – useful for assessing changes in contaminant levels in water	High-effective for determining NAPL distribution – useful for assessing changes in contaminant levels in water	Moderate	High	High	Low	Low

**Table A.2. Evaluation of Southwest Plume Source Area Process Options (Continued)**

General Response Action	Technology Type	Process Option	Effectiveness			Implementability		Relative Cost	
			Long-term effectiveness	Short-term effectiveness	Demonstrated effectiveness and reliability	Technical	Administrative	Capital	O&M
Monitoring (continued)		Gore-sorbers	Low-not useful for compliance monitoring	High-effective for determining NAPL distribution	Moderate	High	High	Low	NA
		Raman spectroscopy	Low-not useful for compliance monitoring	High-effective for determining NAPL distribution	High for locating NAPL	Moderate	High	High	NA
	Groundwater monitoring	Sampling and analysis	High-commonly used for compliance monitoring	High-effective effective for determining NAPL distribution	High	High	High	Moderate – dependent on requirements of monitoring plan	High
		Diffusion bags	High-may be useful for compliance monitoring	High-effective in assessing changes in contaminant levels in water	Moderate	High	High	Moderate	NA
		Borehole fluxmeter	Low-not useful for compliance monitoring	High-effective for determining NAPL distribution	Low	High	High	Moderate	NA
		Ribbon NAPL Sampler	Low-not useful for compliance monitoring	High-effective for determining NAPL distribution	Low	High	High	High-FLUTE liner installation required	NA

**Table A.2. Evaluation of Southwest Plume Source Area Process Options (Continued)**

General Response Action	Technology Type	Process Option	Effectiveness			Implementability		Relative Cost	
			Long-term effectiveness	Short-term effectiveness	Demonstrated effectiveness and reliability	Technical	Administrative	Capital	O&M
<b>Monitoring (continued)</b>		DNAPL interface probe	High-may be useful for compliance monitoring	High-useful for determining effects of treatment on DNAPL mobilization	High	High	High	Low	Low
<b>Monitored natural attenuation</b>	Monitoring and natural processes	Soil and groundwater monitoring; abiotic and biological processes	Potentially high for NAPL and dissolved-phase VOCs	High	Potentially high for NAPL and dissolved-phase VOCs	High	High	Low	Moderate
<b>Removal</b>	Excavators	Backhoes, trackhoes	High-remove source to 9.14 to 12.2 m (30-40 ft) bgs	Moderate-risks to workers in excavation	High	High	High	Low	Low
		Vacuum excavation, remote excavator	High-remove source to 9.14 to 12.2 m (30-40 ft) bgs	High-low risk to workers at surface	High	High	High	Moderate	Moderate
		Crane and clamshell	High-remove source to > 30 m (100 ft) bgs	Moderate-more technically complex; hoisting and rigging concerns	High	Moderate	Moderate	High	High

**Table A.2. Evaluation of Southwest Plume Source Area Process Options (Continued)**

General Response Action	Technology Type	Process Option	Effectiveness			Implementability		Relative Cost	
			Long-term effectiveness	Short-term effectiveness	Demonstrated effectiveness and reliability	Technical	Administrative	Capital	O&M
<b>Removal (Continued)</b>		Large diameter auger	VOCs in excavated area eliminated; "Buffer zone" required for RGA to prevent potential for heaving of aquifer material under lithostatic pressure	Moderate	High	Low	Low	High	Low
	Groundwater extraction	Pumping wells	Low for DNAPL, but high for dissolved-phase contamination	High for groundwater control during implementation	Low for DNAPL	Low in UCRS	Moderate-discharge or reinjection required	High-well installation costs	High-continuous operating costs
<b>Containment</b>	Hydraulic containment	Recharge controls	High – reduces mass flux to groundwater, but increases time over which leaching occurs	High - reduces mass flux to groundwater	Potentially high	High	High	Low	Low

**Table A.2. Evaluation of Southwest Plume Source Area Process Options (Continued)**

General Response Action	Technology Type	Process Option	Effectiveness			Implementability		Relative Cost	
			Long-term effectiveness	Short-term effectiveness	Demonstrated effectiveness and reliability	Technical	Administrative	Capital	O&M
<b>Containment (Continued)</b>		Groundwater extraction	Low in UCRS for DNAPL and dissolved-phase VOCs due to heterogeneity, variable saturation, and downward hydraulic gradient	Moderate for DNAPL and dissolved-phase VOCs due to heterogeneity, variable saturation, and downward hydraulic gradient	Low in UCRS	Low in UCRS	Moderate-discharge or reinjection required	High-well installation costs	High-continuous operating costs
	Surface barriers	RCRA Subtitle C cover	High-reduces mass flux to groundwater, but increases time over which leaching occurs	High - reduces mass flux to groundwater	Moderate	Low	High	High-complex construction	Moderate-ongoing maintenance and monitoring required
		Concrete-based cover	Low-prone to cracking	High - reduces mass flux to groundwater	Low-prone to cracking	Moderate	High	High	High
		Conventional asphalt cover	Low-relatively permeable	High - reduces mass flux to groundwater	Low-relatively permeable	High	High	Low	Moderate
		Low-permeability asphalt	High - reduces mass flux to groundwater, but increases time over which leaching occurs	High- reduces mass flux to groundwater	High	Moderate	High	Moderate	Moderate

**Table A.2. Evaluation of Southwest Plume Source Area Process Options (Continued)**

General Response Action	Technology Type	Process Option	Effectiveness			Implementability		Relative Cost	
			Long-term effectiveness	Short-term effectiveness	Demonstrated effectiveness and reliability	Technical	Administrative	Capital	O&M
Containment (Continued)		Flexible membrane	High - reduces mass flux to groundwater, but increases time over which leaching occurs	High - reduces mass flux to groundwater	Moderate - must be protected from damage	High	High	Moderate	Low
	Subsurface horizontal barriers	Freeze walls	Low - ineffective for environments with vertical hydraulic gradients unless combined with a cover.	Low - ineffective for environments with vertical hydraulic gradients unless combined with a cover	Low - few applications	Low	Moderate	High	High-energy and refrigerant costs
Treatment	Biological	Anaerobic reductive dechlorination	Uncertain for DNAPL; high for dissolved-phase VOCs	Moderate	Moderate	Low	Moderate		
		Aerobic cooxidation	Uncertain for DNAPL; high for dissolved-phase VOCs	Moderate	Moderate	Low	Moderate	Moderate	Moderate
	Physical/chemical	Soil vapor extraction <i>-in situ</i>	Moderate-high - presumptive remedy for VOCs in soil; treats all phases	High	Moderate	Moderate	Moderate	Moderate-extraction well installation	Moderate-ongoing energy costs, long duration
		Multiphase extraction <i>-in situ</i>	High	High	High	Moderate	Moderate	Moderate	Moderate

**Table A.2. Evaluation of Southwest Plume Source Area Process Options (Continued)**

General Response Action	Technology Type	Process Option	Effectiveness			Implementability		Relative Cost	
			Long-term effectiveness	Short-term effectiveness	Demonstrated effectiveness and reliability	Technical	Administrative	Capital	O&M
<b>Treatment (Continued)</b>		Air sparging- <i>in situ</i>	Moderate to high for dissolved-phase; must be combined with SVE	High	Moderate	High	High	High-extraction well installation	High-ongoing energy costs, long duration
		Soil flushing- <i>in situ</i>	Moderate – dependent on soil permeability	Moderate	Low	Low	Low-amendment injection required	High-formulation and injection of surfactants or other amendments	None
		Electrokinetics- <i>in situ</i>	High-demonstrated at PGDP	Low	High	Moderate	High	High	High, short duration
		Hydrofracturing- <i>in situ</i>	Moderate – dependent on soil characteristics and DNAPL distribution	Moderate - dependent on soil characteristics and DNAPL distribution	Low	Low	Moderate	Moderate	None
		Soil mixing- <i>in situ</i>	Moderate to high – dependent on soil characteristics and depth of contaminantion – suitable for NAPL and dissolved-phase contaminants	Moderate to high – dependent on soil characteristics and depth of contaminantion – suitable for NAPL and dissolved-phase contaminants	Low	Moderate	Moderate	High	Varies depending on application



**Table A.2. Evaluation of Southwest Plume Source Area Process Options (Continued)**

General Response Action	Technology Type	Process Option	Effectiveness			Implementability		Relative Cost	
			Long-term effectiveness	Short-term effectiveness	Demonstrated effectiveness and reliability	Technical	Administrative	Capital	O&M
Treatment (Continued)		Air stripping- <i>ex situ</i>	High	High	High	High	Moderate-air emissions	Moderate	Moderate-ongoing energy costs
		Ion exchange- <i>ex situ</i>	High	High	High	High	High	Low	Moderate-ongoing secondary waste treatment and disposal
		Granular activated carbon- <i>ex situ</i>	High	High	High	High	High	Low	High-ongoing carbon replacement costs
		Vapor condensation	High	High Low - few vendors available	Low	Low - few vendors available	High	High	High
		Liquid atomized injection- <i>in situ</i>	Moderate	Moderate	Moderate	Moderate	Moderate	High	Varies depending on application
	Thermal	Catalytic oxidation- <i>ex situ</i>	High	High	High	Moderate	High	High	Moderate-ongoing energy costs
		Electrical resistance heating- <i>in situ</i>	High-demonstrated at PGDP	High; <i>in situ</i> process	High	High	Moderate-air emissions	Moderate	High energy costs during implementation; none after completion
		Thermal desorption- <i>ex situ</i>	High	Moderate; soil must be excavated	High	High	Moderate-air emissions	High	High energy costs during implementation; none after completion

**Table A.2. Evaluation of Southwest Plume Source Area Process Options (Continued)**

General Response Action	Technology Type	Process Option	Effectiveness			Implementability		Relative Cost	
			Long-term effectiveness	Short-term effectiveness	Demonstrated effectiveness and reliability	Technical	Administrative	Capital	O&M
Treatment (continued)		Steam stripping- <i>in situ</i>	Moderate – dependent on soil permeability	Moderate – dependent on soil permeability	Moderate	Moderate	Moderate-air emissions	High	High energy costs during implementation; none after completion
	Chemical	Permanganate- <i>in situ</i>	Low – Does not act directly on DNAPLs	Low – Does not act directly on DNAPLs	Low - treatability study needed	Low in UCRS	Low-amendment injection required	Moderate	Low; primarily monitoring
		Fenton’s reagent- <i>in situ</i>	Low – Does not act directly on DNAPLs	Low – Does not act directly on DNAPLs-used in saturated zone on dissolved-phase contaminants	Low - treatability study needed	Low in UCRS	Low-amendment injection required	Moderate	Low; primarily monitoring
		ZVI- <i>in situ</i>	Moderate – dechlorination of chloroethenes by elemental iron	Moderate – dechlorination of chloroethenes by elemental iron	Moderate	Low in UCRS	Low-amendment injection required	High	Low; primarily monitoring
		Ozonation- <i>in situ</i>	Low – Does not act directly on DNAPLs	Low – Does not act directly on DNAPLs- used in saturated zone on dissolved-phase contaminants	Low - treatability study needed	Low in UCRS	Low-amendment injection required	Low	Moderate; continuing operation of sparge system and monitoring required

**Table A.2. Evaluation of Southwest Plume Source Area Process Options (Continued)**

General Response Action	Technology Type	Process Option	Effectiveness			Implementability		Relative Cost	
			Long-term effectiveness	Short-term effectiveness	Demonstrated effectiveness and reliability	Technical	Administrative	Capital	O&M
Treatment (continued)		Sodium persulfate- <i>in situ</i>	Low – Does not act directly on DNAPLs	Low – Does not act directly on DNAPLs - used in conjunction with ferrous iron as a catalyst	Low - treatability study needed	Low in UCRS	Low-amendment injection required	Moderate	Low; primarily monitoring
		Redox manipulation- <i>in situ</i>	Low – suitable for dissolved-phase VOC contamination in saturated zone	Low – suitable for dissolved-phase VOC contamination in saturated zone	Low - treatability study needed	Low in UCRS	Low-amendment injection required	High	High; longer term O&M
	Monitored natural attenuation	Monitoring and natural processes	Low for NAPL	High	Low for NAPL	High	Low-inadequate for DNAPL	Low	Moderate
Disposal	Land disposal	Off-site permitted commercial disposal facility	High	Moderate-long-distance transportation required	High	High	High	High	None
		On-site C-746-U Landfill	High	High	High	High	High	Low	None-long-term monitoring and maintenance not paid by program
	Discharge to groundwater	Within area of contamination after treatment	High	Moderate	Moderate	High	Low-groundwater injection required	Low	None
	Discharge to surface water	Permitted outfall after treatment	High	High	High	High	Moderate	Moderate	None

**Table A.2. Evaluation of Southwest Plume Source Area Process Options (Continued)**

ARD	anaerobic reductive dechlorination	E/PP	excavation/penetration permit	O&M	operation and maintenance	RNS	ribbon NAPL sampler
bgs	below ground surface	HDPE	high density polyethylene	PFM	passive fluxmeter	SVE	soil vapor extraction
CERCLA	Comprehensive Environmental Response, Compensation, and Liability Act	HW	hazardous waste	PGDP	Paducah Gaseous Diffusion Plant	TCE	trichloroethene
CPT	cone penetrometer	LLW	low-level waste	PITT	partitioning interwell tracer test	UCRS	Upper Continental Recharge System
DNAPL	dense nonaqueous-phase liquid	MIP	membrane interface probe	PRB	permeable reactive barriers	UV	ultraviolet
DPT	direct-push technology	MLLW	mixed low-level waste	RCRA	Resource Conservation and Recovery Act	VOC	volatile organic compound
		NAPL	nonaqueous-phase liquid	RGA	Regional Gravel Aquifer	ZVI	zero-valent iron

**THIS PAGE INTENTIONALLY LEFT BLANK**

**APPENDIX B**  
**COST ESTIMATES**

**THIS PAGE INTENTIONALLY LEFT BLANK**

## Introduction

The following introduction describes the organizational structure of Appendix B of the *Revised Focused Feasibility Study for Solid Waste Management Units 1, 211A, and 211B Volatile Organic Compound Sources for the Southwest Groundwater Plume at the Paducah Gaseous Diffusion Plan, Paducah, Kentucky*, and information on the process used to generate the escalated and present value costs. Feasibility level cost estimates for Alternatives 2 through 8 are included in this appendix. The following spreadsheets are organized by alternative and source area [i.e. Costs for each source area (i.e., C-720 Northeast, C-720 Southeast, and the Oil Landfarm). Each alternative and associated source area cost estimates include separate spreadsheets for the following categories:

- Construction costs: The construction costs are specific to each of the potential remedies for each source area site. These costs include all capital necessary for active implementation of the alternative.
- Operation and Maintenance (O&M) costs: The O&M costs included Regional Gravel Aquifer (RGA) groundwater sampling events for years 1-30. Alternative 7 and 8 have additional O&M costs that are associated with their specific treatment systems. The additional O&M is needed because the specific treatment systems are active for longer than one year. These additional O&M costs are used to calculate the present value.
- General costs: The general costs are similar for each of the alternatives and location. These costs include engineering labor, field labor, material charges, equipment charges, subcontractor charges and other direct charges associated with activities required before construction of an alternative could begin (e.g., remedial design costs, work plan costs, etc.)

The total cost for each category is summarized for each alternative and location in the cost summary table. This table displays the unescalated cost, escalated cost, and present value. An escalation rate of 3% is used and has been obtained from U.S. Department of Energy (DOE) document, "Escalation Rate Assumptions for DOE Projects" (November 27, 2009). The present value is used to determine the amount that should be set aside in the base year to assure that funds will be available in the future, as they are needed. The economic conditions assumed for present value analyses are a discount rate of 2.7% over a 30-year time frame. The general calculation used for present value is as follows:

$$\text{Total PV} = \text{Capital Cost} + \text{Annual Unit Rate} * (\text{P/A}, 2.7\%, 30\text{-years})$$

Where: PV = present value

P/A, 2.7%, 30-years = rate-of-return factor

The RGA groundwater sampling for the first 5 years is included in the general tasks breakdown, but is not distinct. The value for groundwater sampling for the first 5 years is estimated to be approximately \$168,557.



## Assumptions

### General Tasks (as appropriate, some are applicable to technology-specific assumption)

- General tasks are those tasks which are applicable to all technologies. They include Project Plans, Membrane Interface Probe (MIP) Sampling, Soil Cores and Sampling, RGA Wells, 30-year Monitoring.
- Twelve RGA monitoring wells, 53 soil corings, laboratory costs, and data management were included in the labor and equipment costs. General task costs initially were based on application of the technology across all three sites. These costs, level-of-effort, etc., were divided by 1/3 for estimated costs on a per site basis.
- Technical staff all from Columbus, OH. Radcon and escort staff are from Paducah.
- Travel costs:
  - Airfare: \$392/round trip (Columbus-Nashville)
  - Hotel: \$70/night
  - Per Diem: \$46/day
  - Rental car: \$90.63/day
  - Gas: \$2.85/gal; 274 miles Nashville-Paducah round trip + 30 mi/day at/to/from site; average car mileage 30 mi/gal
- Technical Staff: Minimum of two people at all times.
- When in the field Paducah based staff, Radcon, and escort present at all times in addition to technical and subcontractor (e.g., driller) staff:
  - Radcon – 1 person
  - Escort – 1 person for general tasks
- Plans: One set of plans prepared for SW Plume project. The plans will cover all three sites and all technologies used. Cost presented for a given technology at a given site is 1/3 the cost of the set of plans. Plans include the following:
  - Remedial Action Work Plan
  - Health & Safety Plan
  - Security Plan
  - QA Plan
  - Sampling & Analysis Plan
  - Waste Management Plan
- Number of and cost for permits is based on the LATA Kentucky baseline estimates.
- RGA monitoring wells to 70 ft.; will have a temporary decon pad; each well will take one week to complete.

- Soil corings are assumed to have a depth of approximately 60 ft.
- Wastes generated from sampling and well installation activities: 60% hazardous; 40% non-hazardous.
- Construction trailer and change trailer costs include delivery, set-up, furniture rental, and return; source from Williams Scotsman, Inc., Hamilton, OH.
- Waste Disposal:
  - Nonhazardous:
    - Use On-Site Landfill (C-746-U)
    - Disposal Cost and Waste Transportation: \$216/yd<sup>3</sup>
  - Hazardous:
    - Use Clean Harbors Lone Mountain Facility in Oklahoma
    - Disposal Cost: \$200.00/yd<sup>3</sup>
    - Transportation: \$3,000.00/truck load; truck load = 20 yd<sup>3</sup>
- Duration estimates based on work days, not calendar days.
- Materials are assumed to be provided by subcontractors for activities involving them. For example, labs provide preservatives, sampling containers, etc.
- RGA Well monitoring:
  - Duration—5 years
  - Frequency—2 times/year
  - Staff:
    - 2 technical
    - 1 Radcon
    - 1 escort
- Well Maintenance—During the 30-year monitoring period, each of the 12 RGA (4 per site) wells will require maintenance performed 6 times.

**Alternative 3 - *In Situ* Source Treatment using Deep Soil Mixing with Interim Land Use Controls**

- Mixing Area and Volume:
  - SWMU 1:
    - Area – 5,810 ft<sup>2</sup>
    - Depth – Consistent 60 ft.
    - Volume – 12,911 yds<sup>3</sup>
- Soil mixing with 4% overlap in columns.
- Soil mixing using a 6 ft diameter auger.
- Reagent: Zero Valent Iron (ZVI).

- ZVI added in from approximately 10 ft bgs to 60 ft bgs; concrete added in upper 10 ft of column of surface for stabilization; 1% Kaolinite bentonite by weight of soil added throughout column.
- Swell waste generated due to the addition of reagent, bentonite, and concrete 30% of volume is 3,680 yds<sup>3</sup>.
- Bench scale/field test for proper ZVI blend has not been performed. Assume no additional cost for the test.
- During soil mixing actions, 2 escorts needed at the site.
- For site restoration, 1 ft of clean fill; seed \$0.004129/ft<sup>2</sup>; soil deliver \$13/yd<sup>3</sup>; restoration performed by on-site union operator and laborer; equipment includes D5 dozer, roller, and seeder.
- Water available for mixing at/near site.

**Alternative 4 - *In Situ* Source Removal and *In Situ* Chemical Source Treatment with Interim Land Use Controls**

- Budgetary pricing provided by RECON (J. Lewis, Senior Geotechnical Advisor).
- Source area is 5,810 ft<sup>2</sup>.
- Source volume is 12,911 yd<sup>3</sup> based on maximum depth of 60 ft below ground surface.
- An excavation buffer zone of approximately 10 to 13 ft would be maintained between the completed borings and the top of the RGA. This portion of the UCRS would be treated *in situ*.
- Trichloroethene (TCE) concentrations (data from 2005) range from 22 ug/kg to 3,500 ug/kg.
- Sedimentation and erosion controls will be used to contain runoff from excavated soil, and backfill of soil storage areas and will consist of straw bales, silt fencing, and berm construction, as needed. Cost is included in subconsultant fee.
- Decontamination rinseates will be collected in a temporary storage tank (frac tank), sampled at the conclusion of the work, and disposed of properly (assume at no cost in an on-site treatment facility). Cost is included in the subconsultant fee.
- “Clean” overburden will be excavated from the Solid Waste Management Unit (SWMU) 1 footprint and stockpiled for later backfill use during the LDA excavation work. Assume the upper 5 ft of soil (1,075 yd<sup>3</sup>) will be excavated and reused later.
- Work will be performed by a single auger mixing rig (Delmag RH-190) using a 6 ft diameter auger, ZVI mixing and delivery equipment, and excavation equipment consisting of an excavator, small dozer, and wheel loader.
- Based on a 13 ft buffer zone at the base of the 60 ft maximum depth, soil will be removed from 5 ft below ground to 47 feet below ground (9,038 yd<sup>3</sup>).

- The lower 13 ft of the auger run will inject a mixture of ferrous iron reagent (such as ZVI) at a rate of 50% by weight per ft<sup>3</sup> of ZVI (actual treatment will be dependent on later bench scale testing).
- 103 tons of iron (with 25% waste allowance) will be used in the lower 13 ft of the excavated area.
- Iron filings will be delivered to the site in one-ton supersacks, handled by a forklift, and placed in the contractor's shear mixer so it is metered with water during delivery into the formation.
- A 10% overlap was figured in the excavation of the soil columns to ensure there are no windows in the removal of the impacted SWMU 1 soils.
- LDA excavation is estimated to take 2.5 months, with an additional 15 work days to include mobilization, setup, cleanup, and demobilization from the site. Costs are based on working six, 10-hour work days per week.
- Disposal of 9,038 yd<sup>3</sup> of TCE-impacted soil will be required.
- Placement of the original 1,075 yd<sup>3</sup> of stripped off surface soil, purchase of 215 yd<sup>3</sup> of topsoil (SWMU 1 area to a depth of 1 ft) and purchase of 8,823 cy of soil backfill will be necessary to restore the site to original grade. This is 11 20-yd<sup>3</sup> trucks of topsoil and 44 1 20-yd<sup>3</sup> trucks of soil borrow material for backfill.
- Disposal of soils will be at the on-site landfill (C-746-U) for nonhazardous and Clean Harbors Lone Mountain landfill if RCRA F-listed TCE soil is MLLW.
- Assume 60% of the excavated soils (60% x 9,038 yd<sup>3</sup> = 5,423 yd<sup>3</sup>) will be disposed of on-site at the on-site landfill at no cost for disposal, only transportation.
- Assume 40% of the excavated soil (3,615 yd<sup>3</sup>) will be disposed of at Clean Harbors Lone Mountain Facility in Oklahoma.
- 3,615 yd<sup>3</sup> of soil transported to Clean Harbors Lone Mountain Facility in Oklahoma will require 181 trucks each carrying 20 yd<sup>3</sup> of soil.
- Onsite disposal at C-746-U Landfill will require 271 truckloads of soil to be transported.

#### **Alternative 5 - *In Situ* Thermal treatment and Interim Land Use Controls**

- 272 total electrodes
- 68 electrode wells
- 24 UCRS wells
- 8 contingency wells
- 6 digital thermocouple temperature monitoring wells (MWs)
- 18 vacuum monitoring/digital thermocouple temperature MWs
- Well field piping
- Recovery of TCE from vapor using GAC and off-site regeneration
- Assumed similar installation design as C-400 project
- Estimated cost derived from the post review of the first phase of the C-400 project

### **Alternative 6 – *In Situ* Source Treatment Using Liquid Atomized Injections with Interim Land Use Controls**

- Five injection points with a radius of influence of approximately 10 ft at each of the C-720 Sites.
- Fine ZVI particles sourced from Hepure Technologies, Inc., or equivalent. The HCA 200 High Purity Cast Iron product (Fe 92 % to 98 %) is particularly suited for injection due to its small particle size of less than 100 micron, high iron content (minimal oxide layer), and abundance of surface catalytic sites for improved reactivity.
- Vertical injection intervals of 4 ft.
- Injection points would be positioned at least 15 ft from load-bearing columns, walls or structures.
- Storm sewer and sanitary water lines present at the C-720 Southeast Site would be rerouted, as necessary, so that no underground utility lines would be present horizontally within 10 ft of the injection points.
- Injection points at the C-720 Northeast Site would be positioned at least 10 ft horizontally from the recirculating cooling water line.

### **Alternative 7 – *In Situ* Soil Flushing and Source Treatment via Multiphase Extraction with Interim Land Use Controls**

- 2-year duration.
- 3 wells in each C-720 location.
- Injection of a surfactant has been included in the cost estimate for Alternative 7.
- 1 year of office support hours from LATA.
- 12 Sampling events (only for multiphase extraction trailer) spaced over a year (once a month after trailer is up and running).
  - Two samplers for each sampling event
- Sampling materials cost was estimated from previous experience.
- Two workers from LATA would be working on project on-site as oversight. (Costs are rolled into the site superintendent costs, and travel costs have been calculated in the appropriate location).

### **Alternative 8 - *In Situ* Source Treatment using Enhanced *In Situ* Bioremediation with Interim Land Use Controls**

- 6 deep wells (approximately 60 ft depth) within the SWMU 1 source area.
- 6 shallow wells (approximately 20-30 ft depth) within the SWMU 1 source area.
- “Herringbone” design infiltration trench—backfilled with gravel.
- Gravity feed of bioamendment mixture using trench, shallow wells, and deep wells.
- Possible to use wells as feeder wells and/or extraction wells, if necessary.

- Use wells to monitor the vertical distribution of the bioamendment from the trench.

**THIS PAGE INTENTIONALLY LEFT BLANK**

## **ALTERNATIVE COSTS SUMMARY**



**THIS PAGE INTENTIONALLY LEFT BLANK**

**Unescalated Cost**

<b>Alternative</b>	<b>C-720 NE Site (\$M)</b>	<b>C-720 SE Site (\$M)</b>	<b>Oil Landfarm (\$M)</b>
<b>Alternative 1</b> -No further action	\$0	\$0	\$0
<b>Alternative 2</b> -Long-term monitoring	\$2.1	\$2.1	\$2.1
<b>Alternative 3</b> - <i>In situ</i> source treatment using deep soil mixing	\$0	\$0	\$9.5
<b>Alternative 4</b> -Source removal and <i>in situ</i> chemical source treatment	\$0	\$0	\$11.8
<b>Alternative 5</b> - <i>In situ</i> thermal source treatment	\$6.9	\$6.9	\$16.7
<b>Alternative 6</b> - <i>In situ</i> source treatment using LAI	\$3.7	\$3.7	\$0
<b>Alternative 7</b> - <i>In situ</i> soil flushing and source treatment using multiphase extraction	\$4.3	\$4.3	\$0
<b>Alternative 8</b> - <i>In situ</i> source treatment using EISB	\$0	\$0	\$5.9

**Escalated Costs**

<b>Alternative</b>	<b>C-720 NE Site (\$M)</b>	<b>C-720 SE Site (\$M)</b>	<b>Oil Landfarm (\$M)</b>
<b>Alternative 1</b> -No further action	\$0	\$0	\$0
<b>Alternative 2</b> -Long-term monitoring	\$2.2	\$2.2	\$2.2
<b>Alternative 3</b> - <i>In situ</i> source treatment using deep soil mixing	\$0	\$0	\$9.7
<b>Alternative 4</b> -Source removal and <i>in situ</i> chemical source treatment	\$0	\$0	\$12.1
<b>Alternative 5</b> - <i>In situ</i> thermal source treatment	\$7.1	\$7.1	\$17.2
<b>Alternative 6</b> - <i>In situ</i> source treatment using LAI	\$3.8	\$3.8	\$0
<b>Alternative 7</b> - <i>In situ</i> soil flushing and source treatment using multiphase extraction	\$4.4	\$4.4	\$0
<b>Alternative 8</b> - <i>In situ</i> source treatment using EISB	\$0	\$0	\$6.1

**Present Value**

<b>Alternative</b>	<b>C-720 NE Site (\$M)</b>	<b>C-720 SE Site (\$M)</b>	<b>Oil Landfarm (\$M)</b>
<b>Alternative 1</b> -No further action	\$0	\$0	\$0
<b>Alternative 2</b> -Long-term monitoring	\$1.7	\$1.7	\$1.7
<b>Alternative 3</b> - <i>In situ</i> source treatment using deep soil mixing	\$0	\$0	\$9.1
<b>Alternative 4</b> -Source removal and <i>in situ</i> chemical source treatment	\$0	\$0	\$11.4
<b>Alternative 5</b> - <i>In situ</i> thermal source treatment	\$6.5	\$6.5	\$16.3
<b>Alternative 6</b> - <i>In situ</i> source treatment using LAI	\$3.3	\$3.3	\$0
<b>Alternative 7</b> - <i>In situ</i> soil flushing and source treatment using multiphase extraction	\$3.9	\$3.9	\$0
<b>Alternative 8</b> - <i>In situ</i> source treatment using EISB	\$0	\$0	\$5.5

**THIS PAGE INTENTIONALLY LEFT BLANK**

**ALTERNATIVE 2 – LONG-TERM MONITORING WITH INTERIM LAND  
USE CONTROLS**

**COSTS**

**THIS PAGE INTENTIONALLY LEFT BLANK**

**Los Alamos Technical Associates, Inc.**  
**DOE Document # DOE/LX/07-0362&D1**  
**Alternative 2 - Long-Term Monitoring with Interim Land Use Controls-Price Breakdown**  
**C-720 Northeast Site**

<b>ENGINEERING LABOR</b>								
Labor Hours/Price	Personnel	Sr Technology Leader	Sr Project Manager	Project Engineer	Engineer III/ Geologist	Engineer II	Site Sup./Health & Safety	Summary
Subtask/Rate		\$131.00	\$104.00	\$93.00	\$85.00	\$81.00	\$ 69.20	Hours
Remedial Action Work Plan		70	70	140	188			468
Health and Safety Plan		14	14	34	14			76
Security Plan		8	8	28				44
QA Plan		28	28	60	80			196
Sampling and Analysis Plan (RDSI)		28	28	54	70			180
Waste Management Plan		20	20	20	40			100
MIP (Membrane Interface Probe) Sampling (RDSI)		14	14					28
Soil Cores (RDSI)		4	4	8				16
Data Management (RDSI)		8	8	14		268		298
Install RGA Wells (RDSI)		4	4	14		14		36
Data Management (RDSI)						28		28
Site Restoration			8					8
Monitoring/sampling (2 rounds/yr)			34	34	34			102
5 Year Reviews			28	34	80	214		356
								0
	Total Office Hours	198	268	440	506	524	0	1936
	Total Labor PRICE	\$25,938	\$27,872	\$40,920	\$43,010	\$42,444	\$0	<b>\$180,184</b>

<b>FIELD LABOR</b>								
Labor Hours/Price	Personnel	Site Sup.	Laborer 1	Laborer 2	Operator	Radcon	Escort	Summary
Subtask/Rate		\$77.83	\$61.68	\$57.33	\$57.33	\$57.33	\$ 41.10	Hours
MIP Sampling (RDSI)		68	68			48	48	232
Soil Cores (RDSI)		104	104			72	72	352
Install RGA Wells (RDSI)		280			280	200	200	960
Site Restoration		56		40	40	40	80	256
Monitoring/sampling		188			188	134	134	644
								0
	Total Office Hours	696	172	40	508	494	534	2444
	Total Labor PRICE	\$54,170	\$10,609	\$2,293	\$29,124	\$28,321	\$21,947	<b>\$146,464</b>

<b>MATERIAL CHARGES</b>				
Description	Units	Rate	Cost	Comments
Fill (cy)	215	\$13	\$2,792.85	
Seed (sq ft)	5810	\$0	\$23.99	
Soil Delivery (cy)	215	\$12	\$2,580.00	
Well maintenance	4	\$5,000	\$20,000.00	4 wells in each site location.
			\$0.00	
	Subtotal		\$25,397	
	Material Multiplier		1.11	
	<b>Total Material Charges, with Profit:</b>		<b>\$28,190</b>	

**Los Alamos Technical Associates, Inc.**  
**DOE Document # DOE/LX/07-0362&D1**  
**Alternative 2 - Long-Term Monitoring with Interim Land Use Controls-Price Breakdown**  
**C-720 Northeast Site**

<b>EQUIPMENT CHARGES</b>				
Description	Units	Rate	Cost	Comments
Interim LUCs (E/PP Program and Warning signs)	50	\$900	\$45,000.00	
DPT - samples	2120	\$40	\$84,800.00	LATA-KY baseline estimates
Excava. permits - samples	36	\$360	\$12,960.00	LATA-KY baseline estimates
Miscellaneous Equipment	8	\$565	\$4,520.00	
Construction trailer (/month)	1	\$2,000	\$2,000.00	Includes cost of delivery, setup, furniture rental, and return (Williams Scotsman, Inc., Hamilton, Ohio). Cost distributed evenly between three site locations.
Change trailer (/month)	1	\$2,400	\$2,400.00	Includes cost of delivery, setup, furniture rental, and return (Williams Scotsman, Inc., Hamilton, Ohio). Cost distributed evenly between three site locations.
Dozer (/month)	0	\$500	\$0.00	
Roller (/month)	5	\$500	\$2,500.00	
Seeder (/month)	1	\$218	\$218.00	
			\$0.00	
Subtotal			\$154,398	
Material Multiplier			1.11	
<b>Total Material Charges, with Profit:</b>			<b>\$171,382</b>	

<b>SUBCONTRACTOR CHARGES</b>				
Description	Units	Rate	Cost	Comments
driller services	1	\$30,334	\$30,334.00	
surveyor services	59	\$282	\$16,638.00	LATA-KY baseline estimates
laboratory services	708	\$235	\$166,380.00	
RGA laboratory services	8	\$1,000	\$8,000.00	12 RGA monitoring wells.
RGA driller services	1	\$117,467	\$117,467.00	12 RGA monitoring wells. RGA monitoring wells to 70ft.
LT Monitoring laboratory services	50	\$1,000	\$50,000.00	
			\$0.00	
Subtotal			\$388,819	
Material Multiplier			1.11	
<b>Total Material Charges, with Profit:</b>			<b>\$431,589</b>	

<b>Other Direct Charges</b>				
Description	Units	Rate	Cost	Comments
mailing/copying	2	\$500	\$1,000.00	
airfare	23	\$392	\$9,016.00	Columbus to Nashville
hotel (/day)	140	\$70	\$9,800.00	
per diem	161	\$46	\$7,406.00	
car rental (/day)	84	\$91	\$7,612.92	
gas	1	\$500.00	\$500.00	Nashville to Paducah round trip + 30 mi/day; average car mileage 30 mi/gal.
			\$0.00	
Subtotal			\$35,335	
ODC Multiplier			1.11	
<b>Total Material Charges, with Profit:</b>			<b>\$39,222</b>	

<b>SUM OF GENERAL TASKS DETAILED COSTS</b>	<b>\$997,031</b>
15% Contingency	<b>\$149,554.65</b>
<b>TOTAL GENERAL TASKS DETAILED COSTS</b>	<b>\$1,146,586</b>

**Cost Summary Table**

Alternative 2 - Long-Term Monitoring with Interim Land Use Controls / C-720 Northeast

<b>Construction Costs</b>	<b>General Tasks* (Includes first 5 years of RGA groundwater sampling)</b>	<b>General Tasks (no RGA groundwater sampling)</b>
<b>\$0</b>	<b>\$997,031</b>	<b>\$828,474.02</b>

	<u>Unescalated Cost (1)</u>	<u>Escalated Cost (1)</u>	<u>Present Value (1.2)</u>
<b>Capital Costs</b> (Construction Costs and General Task Costs - No RGA groundwater sampling)	<b>\$828,474</b>	<b>\$853,328.24</b>	<b>\$828,474.02</b>
<b>RGA Groundwater Sampling - for first 5 years</b>	<b>\$168,557</b>	<b>\$173,613.71</b>	<b>\$168,557.00</b>
<b>RGA Groundwater Sampling Events (Years 1-30)</b>	<b>\$1,011,342.00</b>	<b>\$1,041,682.26</b>	<b>\$690,611.74</b>
<b>Total Cost</b>	<b>\$1,839,816.02</b>	<b>\$1,895,010.50</b>	<b>\$1,519,085.76</b>
<b>Total Cost with 15% Contingency</b>	<b>\$2,115,788.43</b>	<b>\$2,179,262.08</b>	<b>\$1,746,948.63</b>

1: Includes G&A and fee

2: Present worth costs are based on an assumption that outyear costs will be financed by investments made in year 0, and are provided for purposes of comparison only. Escalated costs are used by the DOE for planning and budgeting.

\*See General Tasks Price Breakdown for line items associated with costs

O&M = Operation and Maintenance

RGA = Regional Gravel Aquifer



**Los Alamos Technical Associates, Inc.**  
**DOE Document # DOE/LX/07-0362&D1**  
**Alternative 2 - Long-Term Monitoring with Interim Land Use Controls-Price Breakdown**  
**C-720 Southeast Site**

<b>ENGINEERING LABOR</b>								
Labor Hours/Price	Personnel	Sr Technology Leader	Sr Project Manager	Project Engineer	Engineer III/ Geologist	Engineer II	Site Sup./Health & Safety	Summary
Subtask/Rate		\$131.00	\$104.00	\$93.00	\$85.00	\$81.00	\$ 69.20	Hours
Remedial Action Work Plan		70	70	140	188			468
Health and Safety Plan		14	14	34	14			76
Security Plan		8	8	28				44
QA Plan		28	28	60	80			196
Sampling and Analysis Plan (RDSI)		28	28	54	70			180
Waste Management Plan		20	20	20	40			100
MIP (Membrane Interface Probe) Sampling (RDSI)		14	14					28
Soil Cores (RDSI)		4	4	8				16
Data Management (RDSI)		8	8	14		268		298
Install RGA Wells (RDSI)		4	4	14		14		36
Data Management (RDSI)						28		28
Site Restoration			8					8
Monitoring/sampling (2 rounds/yr)			34	34	34			102
5 Year Reviews			28	34	80	214		356
								0
	Total Office Hours	198	268	440	506	524	0	1936
	Total Labor PRICE	\$25,938	\$27,872	\$40,920	\$43,010	\$42,444	\$0	<b>\$180,184</b>

<b>FIELD LABOR</b>								
Labor Hours/Price	Personnel	Site Sup.	Laborer 1	Laborer 2	Operator	Radcon	Escort	Summary
Subtask/Rate		\$77.83	\$61.68	\$57.33	\$57.33	\$57.33	\$ 41.10	Hours
MIP Sampling (RDSI)		68	68			48	48	232
Soil Cores (RDSI)		104	104			72	72	352
Install RGA Wells (RDSI)		280			280	200	200	960
Site Restoration		56		40	40	40	80	256
Monitoring/sampling		188			188	134	134	644
								0
	Total Office Hours	696	172	40	508	494	534	2444
	Total Labor PRICE	\$54,170	\$10,609	\$2,293	\$29,124	\$28,321	\$21,947	<b>\$146,464</b>

<b>MATERIAL CHARGES</b>				
Description	Units	Rate	Cost	Comments
Fill (cy)	215	\$13	\$2,792.85	
Seed (sq ft)	5810	\$0	\$23.99	
Soil Delivery (cy)	215	\$12	\$2,580.00	
Well maintenance	4	\$5,000	\$20,000.00	4 wells in each site location.
			\$0.00	
	Subtotal		\$25,397	
	Material Multiplier		1.11	
	<b>Total Material Charges, with Profit:</b>		<b>\$28,190</b>	

**Los Alamos Technical Associates, Inc.**  
**DOE Document # DOE/LX/07-0362&D1**  
**Alternative 2 - Long-Term Monitoring with Interim Land Use Controls-Price Breakdown**  
**C-720 Southeast Site**

<b>EQUIPMENT CHARGES</b>				
Description	Units	Rate	Cost	Comments
Interim LUCs (E/PP Program and Warning signs)	50	\$900	\$45,000.00	
DPT - samples	2120	\$40	\$84,800.00	LATA-KY baseline estimates
Excava. permits - samples	36	\$360	\$12,960.00	LATA-KY baseline estimates
Miscellaneous Equipment	8	\$565	\$4,520.00	
Construction trailer (/month)	1	\$2,000	\$2,000.00	Includes cost of delivery, setup, furniture rental, and return (Williams Scotsman, Inc., Hamilton, Ohio). Cost distributed evenly between three site locations.
Change trailer (/month)	1	\$2,400	\$2,400.00	Includes cost of delivery, setup, furniture rental, and return (Williams Scotsman, Inc., Hamilton, Ohio). Cost distributed evenly between three site locations.
Dozer (/month)	0	\$500	\$0.00	
Roller (/month)	5	\$500	\$2,500.00	
Seeder (/month)	1	\$218	\$218.00	
			\$0.00	
Subtotal			\$154,398	
Material Multiplier			1.11	
<b>Total Material Charges, with Profit:</b>			<b>\$171,382</b>	

<b>SUBCONTRACTOR CHARGES</b>				
Description	Units	Rate	Cost	Comments
driller services	1	\$30,334	\$30,334.00	
surveyor services	59	\$282	\$16,638.00	LATA-KY baseline estimates
laboratory services	708	\$235	\$166,380.00	
RGA laboratory services	8	\$1,000	\$8,000.00	12 RGA monitoring wells.
RGA driller services	1	\$117,467	\$117,467.00	12 RGA monitoring wells. RGA monitoring wells to 70ft.
LT Monitoring laboratory services	50	\$1,000	\$50,000.00	
			\$0.00	
Subtotal			\$388,819	
Material Multiplier			1.11	
<b>Total Material Charges, with Profit:</b>			<b>\$431,589</b>	

<b>Other Direct Charges</b>				
Description	Units	Rate	Cost	Comments
mailing/copying	2	\$500	\$1,000.00	
airfare	23	\$392	\$9,016.00	Columbus to Nashville
hotel (/day)	140	\$70	\$9,800.00	
per diem	161	\$46	\$7,406.00	
car rental (/day)	84	\$91	\$7,612.92	
gas	1	\$500.00	\$500.00	Nashville to Paducah round trip + 30 mi/day; average car mileage 30 mi/gal.
			\$0.00	
Subtotal			\$35,335	
ODC Multiplier			1.11	
<b>Total Material Charges, with Profit:</b>			<b>\$39,222</b>	

<b>SUM OF GENERAL TASKS DETAILED COSTS</b>	<b>\$997,031</b>
15% Contingency	<b>\$149,554.65</b>
<b>TOTAL GENERAL TASKS DETAILED COSTS</b>	<b>\$1,146,586</b>

**Cost Summary Table**

Alternative 2 - Long-Term Monitoring with Interim Land Use Controls / C-720 Southeast

<b>Construction Costs</b>	<b>General Tasks* (Includes first 5 years of RGA groundwater sampling)</b>	<b>General Tasks (no RGA groundwater sampling)</b>
<b>\$0</b>	<b>\$997,031</b>	<b>\$828,474.02</b>

	<u>Unescalated Cost (1)</u>	<u>Escalated Cost (1)</u>	<u>Present Value (1.2)</u>
<b>Capital Costs</b> (Construction Costs and General Task Costs - No RGA groundwater sampling)	<b>\$828,474</b>	<b>\$853,328.24</b>	<b>\$828,474.02</b>
<b>RGA Groundwater Sampling - for first 5 years</b>	<b>\$168,557</b>	<b>\$173,613.71</b>	<b>\$168,557.00</b>
<b>RGA Groundwater Sampling Events (Years 1-30)</b>	<b>\$1,011,342.00</b>	<b>\$1,041,682.26</b>	<b>\$690,611.74</b>
<b>Total Cost</b>	<b>\$1,839,816.02</b>	<b>\$1,895,010.50</b>	<b>\$1,519,085.76</b>
<b>Total Cost with 15% Contingency</b>	<b>\$2,115,788.43</b>	<b>\$2,179,262.08</b>	<b>\$1,746,948.63</b>

1: Includes G&A and fee

2: Present worth costs are based on an assumption that outyear costs will be financed by investments made in year 0, and are provided for purposes of comparison only. Escalated costs are used by the DOE for planning and budgeting.

\*See General Tasks Price Breakdown for line items associated with costs

O&M = Operation and Maintenance

RGA = Regional Gravel Aquifer

**Los Alamos Technical Associates, Inc.**

DOE Document # DOE/LX/07-0362&D1

Alternative 2 - Long-term Monitoring with Interim Land Use Controls Cost Totals-Price Breakdown  
Oil Landfarm

ENGINEERING LABOR								
Labor Hours/Price	Personnel	Sr Technology Leader	Sr Project Manager	Project Engineer	Engineer III/ Geologist	Engineer II	Site Sup./Health & Safety	Summary
Subtask/Rate		\$131.00	\$104.00	\$93.00	\$85.00	\$81.00	\$ 69.20	Hours
Remedial Action Work Plan		70	70	140	188			468
Health and Safety Plan		14	14	34	14			76
Security Plan		8	8	28				44
QA Plan		28	28	60	80			196
Sampling and Analysis Plan (RDSI)		28	28	54	70			180
Waste Management Plan		20	20	20	40			100
MIP (Membrane Interface Probe) Sampling (RDSI)		14	14					28
Soil Cores (RDSI)		4	4	8				16
Data Management (RDSI)		8	8	14		268		298
Install RGA Wells (RDSI)		4	4	14		14		36
Data Management (RDSI)						28		28
Site Restoration			8					8
Monitoring/sampling (2 rounds/yr)			34	34	34			102
5 Year Reviews			28	34	80	214		356
								0
	Total Office Hours	198	268	440	506	524	0	1936
	Total Labor PRICE	\$25,938	\$27,872	\$40,920	\$43,010	\$42,444	\$0	<b>\$180,184</b>

FIELD LABOR								
Labor Hours/Price	Personnel	Site Sup.	Laborer 1	Laborer 2	Operator	Radcon	Escort	Summary
Subtask/Rate		\$77.83	\$61.68	\$57.33	\$57.33	\$57.33	\$ 41.10	Hours
MIP Sampling (RDSI)		68	68			48	48	232
Soil Cores (RDSI)		104	104			72	72	352
Install RGA Wells (RDSI)		280			280	200	200	960
Site Restoration		56		40	40	40	80	256
Monitoring/sampling		188			188	134	134	644
								0
	Total Office Hours	696	172	40	508	494	534	2444
	Total Labor PRICE	\$54,170	\$10,609	\$2,293	\$29,124	\$28,321	\$21,947	<b>\$146,464</b>

MATERIAL CHARGES				
Description	Units	Rate	Cost	Comments
Fill (cy)	215	\$13	\$2,792.85	
Seed (sq ft)	5810	\$0	\$23.99	
Soil Delivery (cy)	215	\$12	\$2,580.00	
Well maintenance	4	\$5,000	\$20,000.00	4 wells in each site location.
			\$0.00	
	Subtotal		\$25,397	
	Material Multiplier		1.11	
	<b>Total Material Charges, with Profit:</b>		<b>\$28,190</b>	

**Los Alamos Technical Associates, Inc.**

DOE Document # DOE/LX/07-0362&D1

Alternative 2 - Long-term Monitoring with Interim Land Use Controls Cost Totals-Price Breakdown  
Oil Landfarm

<b>EQUIPMENT CHARGES</b>				
Description	Units	Rate	Cost	Comments
Interim LUCs (E/PP Program and Warning signs)	50	\$900	\$45,000.00	
DPT - samples	2120	\$40	\$84,800.00	LATA-KY baseline estimates
Excava. permits - samples	36	\$360	\$12,960.00	LATA-KY baseline estimates
Miscellaneous Equipment	8	\$565	\$4,520.00	
Construction trailer (/month)	1	\$2,000	\$2,000.00	Includes cost of delivery, setup, furniture rental, and return (Williams Scotsman, Inc., Hamilton, Ohio). Cost distributed evenly between three site locations.
Change trailer (/month)	1	\$2,400	\$2,400.00	Includes cost of delivery, setup, furniture rental, and return (Williams Scotsman, Inc., Hamilton, Ohio). Cost distributed evenly between three site locations.
Dozer (/month)	0	\$500	\$0.00	
Roller (/month)	5	\$500	\$2,500.00	
Seeder (/month)	1	\$218	\$218.00	
			\$0.00	
Subtotal			\$154,398	
Material Multiplier			1.11	
<b>Total Material Charges, with Profit:</b>			<b>\$171,382</b>	

<b>SUBCONTRACTOR CHARGES</b>				
Description	Units	Rate	Cost	Comments
driller services	1	\$30,334	\$30,334.00	
surveyor services	59	\$282	\$16,638.00	LATA-KY baseline estimates
laboratory services	708	\$235	\$166,380.00	
RGA laboratory services	8	\$1,000	\$8,000.00	12 RGA monitoring wells.
RGA driller services	1	\$117,467	\$117,467.00	12 RGA monitoring wells. RGA monitoring wells to 70ft.
LT Monitoring laboratory services	50	\$1,000	\$50,000.00	
			\$0.00	
Subtotal			\$388,819	
Material Multiplier			1.11	
<b>Total Material Charges, with Profit:</b>			<b>\$431,589</b>	

<b>Other Direct Charges</b>				
Description	Units	Rate	Cost	Comments
mailing/copying	2	\$500	\$1,000.00	
airfare	23	\$392	\$9,016.00	Columbus to Nashville
hotel (/day)	140	\$70	\$9,800.00	
per diem	161	\$46	\$7,406.00	
car rental (/day)	84	\$91	\$7,612.92	
gas	1	\$500.00	\$500.00	Nashville to Paducah round trip + 30 mi/day; average car mileage 30 mi/gal.
			\$0.00	
Subtotal			\$35,335	
ODC Multiplier			1.11	
<b>Total Material Charges, with Profit:</b>			<b>\$39,222</b>	

<b>SUM OF GENERAL TASKS DETAILED COSTS</b>	<b>\$997,031</b>
15% Contingency	<b>\$149,554.65</b>
<b>TOTAL GENERAL TASKS DETAILED COSTS</b>	<b>\$1,146,586</b>

**Cost Summary Table**

Alternative 2 - Long-term Monitoring with Interim Land Use Controls / C-720 Oil Landfarm

Construction Costs	General Tasks* (Includes first 5 years of RGA groundwater sampling)	General Tasks (no RGA groundwater sampling)
\$0	\$997,031	\$828,474.02

	Unescalated Cost (1)	Escalated Cost (1)	Present Value (1,2)
<b>Capital Costs</b> (Construction Costs and General Task Costs - No RGA groundwater sampling included)	\$828,474	\$853,328.24	\$828,474.02
<b>RGA Groundwater Sampling - for first 5 years</b>	\$168,557	\$173,613.71	\$168,557.00
<b>RGA Groundwater Sampling Events (Years 1-30)</b>	\$1,011,342.00	\$1,041,682.26	\$690,611.74
<b>Total Cost</b>	\$1,839,816.02	\$1,895,010.50	\$1,519,085.76
<b>Total Cost with 15% Contingency</b>	\$2,115,788.43	\$2,179,262.08	\$1,746,948.63

1: Includes G&A and fee

2: Present worth costs are based on an assumption that outyear costs will be financed by investments made in year 0, and are provided for purposes of comparison only. Escalated costs are used by the DOE for planning and budgeting.

\*See General Tasks Price Breakdown for line items associated with costs

O&M = Operation and Maintenance

RGA = Regional Gravel Aquifer

**THIS PAGE INTENTIONALLY LEFT BLANK**

**ALTERNATIVE 3 – *IN SITU* SOURCE TREATMENT USING DEEP SOIL  
MIXING WITH INTERIM LAND USE CONTROLS**

**COSTS**



**THIS PAGE INTENTIONALLY LEFT BLANK**

**Los Alamos Technical Associates, Inc.**  
DOE Document # DOE/LX/07-0362&D1

Alternative 3 - *In Situ* Source Treatment Using Deep Soil Mixing with Interim Land Use Controls Construction-Price Breakdown  
Oil Landfarm

ENGINEERING LABOR							
Labor Hours/Price							Summary
Personnel	Sr Technology Leader	Sr Project Manager	Project Engineer	Engineer III/ Geologist	Engineer II	Site Sup./Health & Safety	Hours
Subtask/Rate	\$131.00	\$104.00	\$93.00	\$85.00	\$75.00	\$ 69.20	Total
Deep Soil Mixing	20	20	40				80
							0
Total Office Hours	20	20	40	0	0	0	80
Total Labor PRICE	\$2,620	\$2,080	\$3,720	\$0	\$0	\$0	<b>\$8,420</b>

FIELD LABOR							
Labor Hours/Price							Summary
Personnel	Site Sup.	Laborer 1	Laborer 2	Operator	Radcon	Escort	Hours
Subtask/Rate	\$77.83	\$61.68	\$57.33	\$57.33	\$57.33	\$ 41.10	Total
Deep Soil Mixing	672	672			480	480	2304
							0
							0
2 Radcon techs for 6 months							0
4 escorts for 6 months							0
Total Office Hours	672	672	0	0	480	480	2304
Total Labor PRICE	\$52,302	\$41,449	\$0	\$0	\$27,518	\$19,728	<b>\$140,997</b>

MATERIAL CHARGES				
Description	Units	Rate	Cost	Comments
			\$0.00	60% hazardous; 40% non-hazardous.
Hazardous Waste Disposal (cy)	2297	\$200	\$459,400.00	
Non-Hazardous Waste Disposal/Transportation (cy)	1532	\$216	\$330,912.00	
Hazardous Waste Transportation (/20cy truck load)	109	\$3,000	\$327,000.00	\$3,000/truck load to Lone Mountain, OK.
			\$0.00	
Shipping		\$0	\$0.00	
			\$0.00	
Subtotal			\$1,117,312	
Material Multiplier			1.11	
<b>Total Material Charges, with Profit:</b>			<b>\$1,240,216</b>	

EQUIPMENT CHARGES				
Description	Units	Rate	Cost	Comments
			\$0.00	
			\$0.00	
Subtotal			\$0	
Material Multiplier			1.11	
<b>Total Material Charges, with Profit:</b>			<b>\$0</b>	

**Los Alamos Technical Associates, Inc.**  
 DOE Document # DOE/LX/07-0362&D1  
 Alternative 3 - *In Situ* Source Treatment Using Deep Soil Mixing with Interim Land Use Controls Construction-Price Breakdown  
 Oil Landfarm

<b>SUBCONTRACTOR CHARGES</b>				
Description	Units	Rate	Cost	Comments
			\$0.00	
subconsultant (includes reagent and equipment costs)	1	\$4,469,830	\$4,469,830.00	60 ft. columns; 5,810 ft <sup>2</sup> surface area; ZVI added to bottom 50 ft. of the 60 ft. column; Cement Cap mixed in the top 10 ft of each column. Boring location and spacing assumes 4% overlap.
			\$0.00	
Subtotal			\$4,469,830	
Material Multiplier			1.11	
<b>Total Material Charges, with Profit:</b>			<b>\$4,961,511</b>	

<b>Other Direct Charges</b>				
Description	Units	Rate	Cost	Comments
airfare	20	\$392	\$7,840.00	Columbus to Nashville.
hotel (/day)	144	\$70	\$10,080.00	
per diem	168	\$46	\$7,728.00	
car rental (/day)	84	\$91	\$7,612.92	
gas	1	\$503.00	\$503.00	Nashville to Paducah round trip + 30 mi/day; average car mileage 30 mi/gal.
			\$0.00	
			\$0.00	
Subtotal			\$33,764	
ODC Multiplier			1.11	
<b>Total Material Charges, with Profit:</b>			<b>\$37,478</b>	

<b>SUM OF DSM DETAILED CONSTRUCTION COSTS</b>	<b>\$6,388,623</b>
15% Contingency	\$958,293
<b>TOTAL DSM DETAILED CONSTRUCTION COSTS</b>	<b>\$7,346,916</b>

**Los Alamos Technical Associates, Inc.**  
**DOE Document # DOE/LX/07-0362&D1**  
**Oil Landfarm General Tasks-Price Breakdown**

<b>ENGINEERING LABOR</b>							
Labor Hours/Price							Summary
Personnel	Sr Technolog y Leader	Sr Project Manager	Project Engineer	Engineer III/ Geologist	Engineer II	Site Sup./Health & Safety	Hours Total
Subtask/Rate	\$131.00	\$104.00	\$93.00	\$85.00	\$81.00	\$ 69.20	
Remedial Action Work Plan	70	70	140	188			468
Health and Safety Plan	14	14	34	14			76
Security Plan	8	8	28				44
QA Plan	28	28	60	80			196
Sampling and Analysis Plan (RDSI)	28	28	54	70			180
Waste Management Plan	20	20	20	40			100
MIP (Membrane Interface Probe) Sampling (RDSI)	14	14					28
Soil Cores (RDSI)	4	4	8				16
Data Management (RDSI)	8	8	14		268		298
Install RGA Wells (RDSI)	4	4	14		14		36
Data Management (RDSI)					28		28
Site Restoration		8					8
Monitoring/sampling (2 rounds/yr)		34	34	34			102
5 Year Reviews		28	34	80	214		356
							0
Total Office Hours	198	268	440	506	524	0	1468
Total Labor PRICE	\$25,938	\$27,872	\$40,920	\$43,010	\$42,444	\$0	<b>\$180,184</b>

<b>FIELD LABOR</b>							
Labor Hours/Price							Summary
Personnel	Site Sup.	Laborer 1	Laborer 2	Operator	Radcon	Escort	Hours Total
Subtask/Rate	\$77.83	\$61.68	\$57.33	\$57.33	\$57.33	\$ 41.10	
MIP Sampling (RDSI)	68	68			48	48	232
Soil Cores (RDSI)	104	104			72	72	352
Install RGA Wells (RDSI)	280			280	200	200	960
Site Restoration	56		40	40	40	80	256
Monitoring/sampling	188			188	134	134	644
							0
Total Office Hours	696	172	40	508	494	534	2444
Total Labor PRICE	\$54,170	\$10,609	\$2,293	\$29,124	\$28,321	\$21,947	<b>\$146,464</b>

**Los Alamos Technical Associates, Inc.**  
**DOE Document # DOE/LX/07-0362&D1**  
**Oil Landfarm General Tasks-Price Breakdown**

<b>MATERIAL CHARGES</b>				
Description	Units	Rate	Cost	Comments
Fill (cy)	215	\$13	\$2,792.85	
Seed (sq ft)	5810	\$0	\$23.99	
Soil Delivery (cy)	215	\$12	\$2,580.00	
Well maintenance	4	\$5,000	\$20,000.00	4 wells in each site location.
			\$0.00	
		Subtotal	\$25,397	
		Material Multiplier	1.11	
		<b>Total Material Charges, with Profit:</b>	<b>\$28,190</b>	

<b>EQUIPMENT CHARGES</b>				
Description	Units	Rate	Cost	Comments
Interim LUCs (E/PP Program and Warning signs)	50	\$900	\$45,000.00	
DPT - samples	2120	\$40	\$84,800.00	LATA-KY baseline estimates.
Excava. permits - samples	36	\$360	\$12,960.00	LATA-KY baseline estimates.
Miscellaneous Equipment	8	\$565	\$4,520.00	
Construction trailer (/month)	1	\$2,000	\$2,000.00	Includes cost of delivery, setup, furniture rental, and return (Williams Scotsman, Inc., Hamilton, Ohio). Cost distributed between three site locations.
Change trailer (/month)	1	\$2,400	\$2,400.00	Includes cost of delivery, setup, furniture rental, and return (Williams Scotsman, Inc., Hamilton, Ohio). Cost distributed between three site locations.
Dozer (/month)	5	\$500	\$2,500.00	
Roller (/month)	5	\$500	\$2,500.00	
Seeder (/month)	1	\$218	\$218.00	
			\$0.00	
		Subtotal	\$156,898	
		Material Multiplier	1.11	
		<b>Total Material Charges, with Profit:</b>	<b>\$174,157</b>	

**Los Alamos Technical Associates, Inc.**  
**DOE Document # DOE/LX/07-0362&D1**  
**Oil Landfarm General Tasks-Price Breakdown**

<b>SUBCONTRACTOR CHARGES</b>				
Description	Units	Rate	Cost	Comments
driller services	1	\$30,334	\$30,334.00	
surveyor services	59	\$282	\$16,638.00	LATA-KY baseline estimates.
laboratory services	708	\$235	\$166,380.00	
RGA laboratory services	8	\$1,000	\$8,000.00	12 RGA monitoring wells.
RGA driller services	1	\$117,467	\$117,467.00	12 RGA monitoring wells. RGA monitoring wells to 70ft.
LT Monitoring laboratory services	50	\$1,000	\$50,000.00	
			\$0.00	
Subtotal			\$388,819	
Material Multiplier			1.11	
<b>Total Material Charges, with Profit:</b>			<b>\$431,589</b>	

<b>Other Direct Charges</b>				
Description	Units	Rate	Cost	Comments
mailing/copying	2	\$500	\$1,000.00	
airfare	23	\$392	\$9,016.00	Columbus to Nashville.
hotel (/day)	140	\$70	\$9,800.00	
per diem	161	\$46	\$7,406.00	
car rental (/day)	84	\$91	\$7,612.92	
gas	1	\$500.00	\$500.00	Nashville to Paducah round trip + 30 mi/day; average car mileage 30 mi/gal.
			\$0.00	
Subtotal			\$35,335	
ODC Multiplier			1.11	
<b>Total Material Charges, with Profit:</b>			<b>\$39,222</b>	

<b>SUM OF GENERAL TASKS DETAILED COSTS</b>	<b>\$999,806</b>
15% Contingency	\$149,971
<b>TOTAL GENERAL TASKS DETAILED COSTS</b>	<b>\$1,149,777</b>

**Cost Summary Table**

Alternative 3 - *In Situ* Source Treatment Using Deep Soil Mixing with Interim Land Use Controls / Oil Landfarm

<b>Construction Costs</b>	<b>General Tasks* (Includes first 5 years of RGA groundwater sampling)</b>	<b>General Tasks (no RGA groundwater sampling)</b>
<b>\$6,388,623</b>	<b>\$999,806</b>	<b>\$831,249</b>

	<b><u>Unescalated Cost (1)</u></b>	<b><u>Escalated Cost (1)</u></b>	<b><u>Present Value (1,2)</u></b>
<b>Capital Costs</b> (Construction Costs and General Task Costs - No RGA groundwater sampling included)	<b>\$7,219,872</b>	<b>\$7,436,467.87</b>	<b>\$7,219,871.71</b>
<b>RGA Groundwater Sampling - for first 5 years</b>	<b>\$168,557</b>	<b>\$173,613.71</b>	<b>\$168,557.00</b>
<b>RGA Groundwater Sampling Events (Years 1-30)</b>	<b>\$1,011,342.00</b>	<b>\$1,041,682.26</b>	<b>\$690,611.74</b>
<b>Total Cost</b>	<b>\$8,231,213.71</b>	<b>\$8,478,150.13</b>	<b>\$7,910,483.45</b>
<b>Total Cost with 15% Contingency</b>	<b>\$9,465,895.77</b>	<b>\$9,749,872.64</b>	<b>\$9,097,055.97</b>

1: Includes G&A and fee

2: Present worth costs are based on an assumption that outyear costs will be financed by investments made in year 0, and are provided for purposes of comparison only. Escalated costs are used by the DOE for planning and budgeting.

\*See General Tasks Price Breakdown for line items associated with costs

O&M = Operation and Maintenance

RGA = Regional Gravel Aquifer

**ALTERNATIVE 4 – SOURCE REMOVAL AND *IN SITU* CHEMICAL  
SOURCE TREATMENT WITH INTERIM LAND USE CONTROLS**

**COSTS**



**THIS PAGE INTENTIONALLY LEFT BLANK**

**Los Alamos Technical Associates, Inc.**  
DOE Document # DOE/LX/07-0362&D1

Alternative 4 - Source Removal and In Situ Chemical Source Treatment with Interim Land Use Controls Construction -Price Breakdown  
Oil Landfarm

ENGINEERING LABOR							
Labor Hours/Price							Summary
Personnel	Sr Technology Leader	Sr Project Manager	Project Engineer	Engineer III/ Geologist	Engineer II	Site Sup./Health & Safety	Hours
Subtask/Rate	\$131.00	\$104.00	\$93.00	\$85.00	\$75.00	\$ 69.20	Total
Large Diameter Auger Excavation	20	20	40				80
							0
Total Office Hours	20	20	40	0	0	0	80
Total Labor PRICE	\$2,620	\$2,080	\$3,720	\$0	\$0	\$0	<b>\$8,420</b>

FIELD LABOR							
Labor Hours/Price							Summary
Personnel	Site Sup.	Laborer 1	Laborer 2	Operator	Radcon	Escort	Hours
Subtask/Rate	\$77.83	\$61.68	\$57.33	\$57.33	\$57.33	\$ 41.10	Total
LDA Excavation	893.76	893.76			638.4	1276.8	3702.72
							0
Total Office Hours	893.76	893.76	0	0	638.4	1276.8	3703
Total Labor PRICE	\$69,561	\$55,127	\$0	\$0	\$36,599	\$52,476	<b>\$213,764</b>

MATERIAL CHARGES				
Description	Units	Rate	Cost	Comments
Waste Disposal (60% haz/40% non-haz)	13557	\$0	\$0.00	
Hazardous Waste Disposal (cy)	8134.5	\$200	\$1,626,900.00	
Non-Hazardous Waste Disposal/Transportation (cy)	5422.5	\$216	\$1,171,260.00	
Hazardous Waste Transportation (/20cy truck load)	406.5	\$3,000	\$1,219,500.00	\$3,000/truck load to Lone Mountain, OK.
Soil Backfill (cy)		\$0	\$0.00	
Original material excavated (cy)	1075	\$0	\$0.00	
Purchased Clean borrow material (cy)	13234.5	\$13	\$172,048.50	Includes transportation and materials.
Shipping	0	\$0	\$0.00	
			\$0.00	
Subtotal			\$4,189,709	
Material Multiplier			1.11	
<b>Total Material Charges, with Profit:</b>			<b>\$4,650,576</b>	

EQUIPMENT CHARGES				
Description	Units	Rate	Cost	Comments
			\$0.00	
Subtotal			\$0	
Material Multiplier			1.11	
<b>Total Material Charges, with Profit:</b>			<b>\$0</b>	

**Los Alamos Technical Associates, Inc.**  
DOE Document # DOE/LX/07-0362&D1

Alternative 4 - Source Removal and In Situ Chemical Source Treatment with Interim Land Use Controls Construction -Price Breakdown  
Oil Landfarm

<b>SUBCONTRACTOR CHARGES</b>				
Description	Units	Rate	Cost	Comments
			\$0.00	
subconsultant (includes equipment costs)	1.33	\$2,357,330	\$3,135,248.90	60 ft. columns (will excavate to approximately 10 ft above top of RGA); 5,810 sf surface area; Boring spacing and locations assume overlap such that 100% of material in excavation zone removed.
	0	\$0.00	\$0.00	
			\$0.00	
Subtotal			\$3,135,249	
Material Multiplier			1.11	
<b>Total Material Charges, with Profit:</b>			<b>\$3,480,126</b>	

<b>Other Direct Charges</b>				
Description	Units	Rate	Cost	Comments
airfare	26.6	\$392	\$10,427.20	Columbus to Nashville.
hotel (/day)	191.52	\$70	\$13,406.40	
per diem	223.44	\$46	\$10,278.24	
car rental (/day)	111.72	\$91	\$10,125.18	
gas	2	\$503.00	\$1,006.00	Nashville to Paducah round trip + 30 mi/day; average car mileage 30 mi/gal.
			\$0.00	
			\$0.00	
Subtotal			\$45,243	
ODC Multiplier			1.11	
<b>Total Material Charges, with Profit:</b>			<b>\$50,220</b>	

<b>SUM OF DSM DETAILED CONSTRUCTION COSTS</b>	<b>\$8,403,107</b>
15% Contingency	\$1,260,466
<b>TOTAL DSM DETAILED CONSTRUCTION COSTS</b>	<b>\$9,663,573</b>

**Los Alamos Technical Associates, Inc.**  
**DOE Document # DOE/LX/07-0362&D1**  
**Oil Landfarm General Tasks-Price Breakdown**

<b>ENGINEERING LABOR</b>							
Labor Hours/Price							Summary
Personnel	Sr Technology Leader	Sr Project Manager	Project Engineer	Engineer III/ Geologist	Engineer II	Site Sup./Health & Safety	Hours
Subtask/Rate	\$131.00	\$104.00	\$93.00	\$85.00	\$81.00	\$ 69.20	Total
Remedial Action Work Plan	70	70	140	188			468
Health and Safety Plan	14	14	34	14			76
Security Plan	8	8	28				44
QA Plan	28	28	60	80			196
Sampling and Analysis Plan (RDSI)	28	28	54	70			180
Waste Management Plan	20	20	20	40			100
MIP (Membrane Interface Probe) Sampling (RDSI)	14	14					28
Soil Cores (RDSI)	4	4	8				16
Data Management (RDSI)	8	8	14		268		298
Install RGA Wells (RDSI)	4	4	14		14		36
Data Management (RDSI)					28		28
Site Restoration		8					8
Monitoring/sampling (2 rounds/yr)		34	34	34			102
5 Year Reviews		28	34	80	214		356
							0
Total Office Hours	198	268	440	506	524	0	1936
Total Labor PRICE	\$25,938	\$27,872	\$40,920	\$43,010	\$42,444	\$0	<b>\$180,184</b>

<b>FIELD LABOR</b>							
Labor Hours/Price							Summary
Personnel	Site Sup.	Laborer 1	Laborer 2	Operator	Radcon	Escort	Hours
Subtask/Rate	\$77.83	\$61.68	\$57.33	\$57.33	\$57.33	\$ 41.10	Total
MIP Sampling (RDSI)	68	68			48	48	232
Soil Cores (RDSI)	104	104			72	72	352
Install RGA Wells (RDSI)	280			280	200	200	960
Site Restoration	56		40	40	40	80	256
Monitoring/sampling	188			188	134	134	644
							0
Total Office Hours	696	172	40	508	494	534	2444
Total Labor PRICE	\$54,170	\$10,609	\$2,293	\$29,124	\$28,321	\$21,947	<b>\$146,464</b>

**Los Alamos Technical Associates, Inc.**  
**DOE Document # DOE/LX/07-0362&D1**  
**Oil Landfarm General Tasks-Price Breakdown**

<b>MATERIAL CHARGES</b>				
Description	Units	Rate	Cost	Comments
Fill (cy)	215	\$13	\$2,792.85	
Seed (sq ft)	5810	\$0	\$23.99	
Soil Delivery (cy)	215	\$12	\$2,580.00	
Well maintenance	4	\$5,000	\$20,000.00	4 wells in each site location.
			\$0.00	
Subtotal			\$25,397	
Material Multiplier			1.11	
<b>Total Material Charges, with Profit:</b>			<b>\$28,190</b>	

<b>EQUIPMENT CHARGES</b>				
Description	Units	Rate	Cost	Comments
Interim LUCs (E/PP Program and Warning signs)	50	\$900	\$45,000.00	
DPT - samples	2120	\$40	\$84,800.00	LATA-KY baseline estimates.
Excava. permits - samples	36	\$360	\$12,960.00	LATA-KY baseline estimates.
Miscellaneous Equipment	8	\$565	\$4,520.00	
Construction trailer (/month)	1	\$2,000	\$2,000.00	Includes cost of delivery, setup, furniture rental, and return (Williams Scotsman, Inc., Hamilton, Ohio). Cost distributed between three site locations.
Change trailer (/month)	1	\$2,400	\$2,400.00	Includes cost of delivery, setup, furniture rental, and return (Williams Scotsman, Inc., Hamilton, Ohio). Cost distributed between three site locations.
Dozer (/month)	5	\$500	\$2,500.00	
Roller (/month)	5	\$500	\$2,500.00	
Seeder (/month)	1	\$218	\$218.00	
			\$0.00	
Subtotal			\$156,898	
Material Multiplier			1.11	
<b>Total Material Charges, with Profit:</b>			<b>\$174,157</b>	

**Los Alamos Technical Associates, Inc.**  
**DOE Document # DOE/LX/07-0362&D1**  
**Oil Landfarm General Tasks-Price Breakdown**

<b>SUBCONTRACTOR CHARGES</b>				
Description	Units	Rate	Cost	Comments
driller services	1	\$30,334	\$30,334.00	
surveyor services	59	\$282	\$16,638.00	LATA-KY baseline estimates.
laboratory services	708	\$235	\$166,380.00	
RGA laboratory services	8	\$1,000	\$8,000.00	12 RGA monitoring wells.
RGA driller services	1	\$117,467	\$117,467.00	12 RGA monitoring wells. RGA monitoring wells to 70ft.
LT Monitoring laboratory services	50	\$1,000	\$50,000.00	
			\$0.00	
Subtotal			\$388,819	
Material Multiplier			1.11	
<b>Total Material Charges, with Profit:</b>			<b>\$431,589</b>	

<b>Other Direct Charges</b>				
Description	Units	Rate	Cost	Comments
mailing/copying	2	\$500	\$1,000.00	
airfare	23	\$392	\$9,016.00	Columbus to Nashville.
hotel (/day)	140	\$70	\$9,800.00	
per diem	161	\$46	\$7,406.00	
car rental (/day)	84	\$91	\$7,612.92	
gas	1	\$500.00	\$500.00	Nashville to Paducah round trip + 30 mi/day; average car mileage 30 mi/gal.
			\$0.00	
Subtotal			\$35,335	
ODC Multiplier			1.11	
<b>Total Material Charges, with Profit:</b>			<b>\$39,222</b>	

<b>SUM OF GENERAL TASKS DETAILED COSTS</b>	<b>\$999,806</b>
15% Contingency	\$149,971
<b>TOTAL GENERAL TASKS DETAILED COSTS</b>	<b>\$1,149,777</b>

**Cost Summary Table**

Alternative 4 - Source Removal and *In Situ* Chemical Source Treatment with Interim Land Use Controls / Oil Landfarm

<b>Construction Costs</b>	<b>General Tasks* (Includes first 5 years of RGA groundwater sampling)</b>	<b>General Tasks (no RGA groundwater sampling)</b>
<b>\$8,403,107</b>	<b>\$999,806</b>	<b>\$831,249</b>

	<u>Unescalated Cost (1)</u>	<u>Escalated Cost (1)</u>	<u>Present Value (1,2)</u>
<b>Capital Costs</b> (Construction Costs and General Task Costs - No RGA groundwater sampling included)	<b>\$9,234,356</b>	<b>\$9,511,386.58</b>	<b>\$9,234,355.90</b>
<b>RGA Groundwater Sampling - for first 5 years</b>	<b>\$168,557</b>	<b>\$173,613.71</b>	<b>\$168,557.00</b>
<b>RGA Groundwater Sampling Events (Years 1-30)</b>	<b>\$1,011,342.00</b>	<b>\$1,041,682.26</b>	<b>\$690,611.74</b>
<b>Total Cost</b>	<b>\$10,245,697.90</b>	<b>\$10,553,068.84</b>	<b>\$9,924,967.64</b>
<b>Total Cost with 15% Contingency</b>	<b>\$11,782,552.59</b>	<b>\$12,136,029.17</b>	<b>\$11,413,712.79</b>

1: Includes G&A and fee

2: Present worth costs are based on an assumption that outyear costs will be financed by investments made in year 0, and are provided for purposes of comparison only. Escalated costs are used by the DOE for planning and budgeting.

\*See General Tasks Price Breakdown for line items associated with costs

O&M = Operation and Maintenance

RGA = Regional Gravel Aquifer

**ALTERNATIVE 5 –*IN SITU* THERMAL TREATMENT AND INTERIM  
LAND USE CONTROLS**

**COSTS**



**THIS PAGE INTENTIONALLY LEFT BLANK**

**Los Alamos Technical Associates, Inc.**  
 DOE Document # DOE/LX/07-0362&D1  
 Alternative 5 - *In Situ* Thermal Treatment and Interim Land Use Controls Construction-Price Breakdown  
 C-720 Northeast Site

<b>ENGINEERING LABOR</b>							
Labor Hours/Price							Summary
Personnel	Sr Technology Leader	Sr Project Manager	Project Engineer	Engineer III/ Geologist	Engineer II	Site Sup./Health & Safety	Hours
Subtask/Rate	\$131.00	\$104.00	\$93.00	\$85.00	\$81.00	\$ 69.20	Total
ERH Construction	154.61	276.15	364.13	1289.74	110.87	543.81	2739.313333
ERH Start Up	44.17	66.35	122.67	181.39	10.89	125.87	551.3266667
ERH O&M	110.44	331.75	260.11	929.82	29.78	520.14	2182.036667
ERH Post OPS (Sampling & D&D)	88.33	1290.25	183.23	251.41	9.43	250.57	2073.226667
							0
							0
Total Office Hours	397.553333	1964.5	930.1266667	2652	160.9666667	1440.39667	7546
Total Labor PRICE	\$52,079	\$204,308	\$86,502	\$225,451	\$13,038	\$99,675	<b>\$681,054</b>

<b>FIELD LABOR</b>							
Labor Hours/Price							Summary
Personnel	Site Sup.	Laborer 1	Laborer 2	Operator	Radcon	Escort	Hours
Subtask/Rate	\$77.83	\$61.68	\$57.33	\$57.33	\$57.33	\$ 41.10	Total
ERH Construction	191.60	224.00	1424.74	1545.84	1009.04	973.24	5368.453333
ERH Start Up	54.73			221.04	50.44	77.08	403.2966667
ERH O&M	355.19		1652.19	1243.33	63.07	385.40	3699.18
ERH Post OPS (Sampling & D&D)	204.49		663.10	275.63	100.92	77.08	1321.216667
							0
							0
Total Office Hours	806.003333	224	3740.023333	3286	1223.48	1512.79667	10792
Total Labor PRICE	\$62,731	\$13,816	\$214,416	\$188,377	\$70,142	\$62,176	<b>\$611,659</b>

<b>MATERIAL CHARGES</b>				
Description	Units	Rate	Cost	Comments
Materials (Construction)	0.2	\$315,000	\$63,000.00	
Materials (Start Up)	0.2	\$25,000	\$5,000.00	
Materials (O&M)	0.2	\$50,000	\$10,000.00	
Materials (Post OPS)	0.2	\$4,000	\$800.00	
			\$0.00	
Shipping	1	\$0	\$0.00	
			\$0.00	
Subtotal			\$78,800	
Material Multiplier			1.11	
<i>Total Material Charges, with Profit:</i>			<b>\$87,468</b>	

<b>EQUIPMENT CHARGES</b>				
Description	Units	Rate	Cost	Comments
Rental (Construction)	0.2	\$443,000	\$88,600.00	
Rental (Start Up)	0.2	\$370,000	\$74,000.00	
Rental (O&M)	0.2	\$1,860,000	\$372,000.00	
Rental (Post OPS)	0.2	\$96,000	\$19,200.00	
			\$0.00	
			\$0.00	
Subtotal			\$553,800	
Material Multiplier			1.11	
<i>Total Material Charges, with Profit:</i>			<b>\$614,718</b>	

**Los Alamos Technical Associates, Inc.**  
 DOE Document # DOE/LX/07-0362&D1  
 Alternative 5 - *In Situ* Thermal Treatment and Interim Land Use Controls Construction-Price Breakdown  
 C-720 Northeast Site

<b>SUBCONTRACTOR CHARGES</b>				
Description	Units	Rate	Cost	Comments
<b>Construction</b>				
laboratory services	0.2	\$200,000	\$40,000	
driller services	0.2	\$2,400,000	\$480,000	
USEC	0.2	\$50,000	\$10,000	
design sub	0.2	\$60,000	\$12,000	
ERH subconsultant	0.2	\$1,285,000	\$257,000	
construction subcontractor	0.2	\$500,000	\$100,000	
transportation subcontractor	0.2	\$1,780,000	\$356,000	
waste treatment	0.2	\$310,000	\$62,000	
<b>Start Up</b>				
laboratory services	0.2	\$25,000	\$5,000	
USEC	0.2	\$10,000	\$2,000	
design sub	0.2	\$10,000	\$2,000	
ERH subconsultant	0.2	\$68,000	\$13,600	
construction subcontractor	0.2	\$100,000	\$20,000	
<b>O&amp;M</b>				
laboratory services	0.2	\$200,000	\$40,000	
USEC	0.2	\$50,000	\$10,000	
ERH subconsultant	0.2	\$1,808,000	\$361,600	
<b>Post OPS (Sampling &amp; D&amp;D)</b>				
laboratory services	0.2	\$395,220	\$79,044	
ERH subconsultant	0.2	\$760,200	\$152,040	
			\$0.00	
			\$0.00	
Subtotal			\$2,002,284	
Material Multiplier			1.11	
<b>Total Material Charges, with Profit:</b>			<b>\$2,222,535</b>	

<b>Other Direct Charges</b>				
Description	Units	Rate	Cost	Comments
airfare		\$392	\$0.00	
hotel (/day)		\$70	\$0.00	
per diem		\$46	\$0.00	
car rental (/day)		\$91	\$0.00	
gas		\$503.00	\$0.00	
			\$0.00	
			\$0.00	
Subtotal			\$0	
ODC Multiplier			1.11	
<b>Total Material Charges, with Profit:</b>			<b>\$0</b>	

<b>SUM OF ERH DETAILED CONSTRUCTION COSTS</b>	<b>\$4,217,433</b>
15% Contingency	\$632,615
<b>TOTAL ERH DETAILED CONSTRUCTION COSTS</b>	<b>\$4,850,048</b>

**Los Alamos Technical Associates, Inc.**  
**DOE Document # DOE/LX/07-0362&D1**  
**C-720 Northeast Site General Tasks-Price Breakdown**

<b>ENGINEERING LABOR</b>								
Labor Hours/Price	Personnel	Sr Technology Leader	Sr Project Manager	Project Engineer	Engineer III/Geologist	Engineer II	Site Sup./Health & Safety	Summary Hours
Subtask/Rate		\$131.00	\$104.00	\$93.00	\$85.00	\$81.00	\$ 69.20	Total
Remedial Action Work Plan			45.33		62.67	47.26		155.3
Health and Safety Plan			4.67		10.00			14.7
Security Plan			2.67					2.7
QA Plan			16.67		33.02		7.80	57.5
Sampling and Analysis Plan (RDSI)			16.67		73.45			90.1
Waste Management Plan			13.33		13.33	8.47		35.1
MIP (Membrane Interface Probe) Sampling (RDSI)	14		14					28
Soil Cores (RDSI)	4		4	8				16
Data Management (RDSI)	8		8	14		268		298
Install RGA Wells (RDSI)	4		4	14		14		36
Data Management (RDSI)						28		28
Site Restoration			8					8
Monitoring/sampling (2 rounds/yr)			34	34	34			102
5 Year Reviews			28	34	80	214		356
								0
Total Office Hours	30	199.3333333	104	306	579.7266667	7.8033333		1072
Total Labor PRICE	\$3,930	\$20,731	\$9,672	\$26,050	\$46,958	\$540		<b>\$107,880</b>

<b>FIELD LABOR</b>								
Labor Hours/Price	Personnel	Site Sup.	Laborer 1	Laborer 2	Operator	Radcon	Escort	Summary Hours
Subtask/Rate		\$77.83	\$61.68	\$57.33	\$57.33	\$57.33	\$ 41.10	Total
MIP Sampling (RDSI)		68	68			48	48	232
Soil Cores (RDSI)		104	104			72	72	352
Install RGA Wells (RDSI)		280			280	200	200	960
Site Restoration		56		40	40	40	80	256
Monitoring/sampling		188			188	134	134	644
								0
Total Office Hours	696	172	40	508	494	534		2444
Total Labor PRICE	\$54,170	\$10,609	\$2,293	\$29,124	\$28,321	\$21,947		<b>\$146,464</b>

<b>MATERIAL CHARGES</b>				
Description	Units	Rate	Cost	Comments
Well maintenance (/well)	4	\$5,000	\$20,000.00	4 wells in each site location.
			\$0.00	
			\$20,000	
			1.11	
			<b>\$22,200</b>	

Subtotal  
Material Multiplier  
**Total Material Charges, with Profit:**

**Los Alamos Technical Associates, Inc.**  
**DOE Document # DOE/LX/07-0362&D1**  
**C-720 Northeast Site General Tasks-Price Breakdown**

<b>EQUIPMENT CHARGES</b>				
Description	Units	Rate	Cost	Comments
Interim LUCs (E/PP Program and Warning signs)	50	\$900	\$45,000.00	
DPT - samples	2120	\$40	\$84,800.00	LATA-KY baseline estimates.
Excava. permits - samples	36	\$360	\$12,960.00	LATA-KY baseline estimates.
Miscellaneous Equipment	8	\$565	\$4,520.00	
Construction trailer (/month)	1	\$2,000	\$2,000.00	Includes cost of delivery, setup, furniture rental, and return (Williams Scotsman, Inc., Hamilton, Ohio). Cost distributed between three site locations.
Change trailer (/month)	1	\$2,400	\$2,400.00	Includes cost of delivery, setup, furniture rental, and return (Williams Scotsman, Inc., Hamilton, Ohio). Cost distributed between three site locations.
Dozer (/month)	5	\$500	\$2,500.00	
Roller (/month)	5	\$500	\$2,500.00	
Seeder (/month)	1	\$218	\$218.00	
			\$0.00	
Subtotal			\$156,898	
Material Multiplier			1.11	
<b>Total Material Charges, with Profit:</b>			<b>\$174,157</b>	

<b>SUBCONTRACTOR CHARGES</b>				
Description	Units	Rate	Cost	Comments
driller services	1	\$30,334	\$30,334.00	
surveyor services	59	\$282	\$16,638.00	LATA-KY baseline estimates.
laboratory services	708	\$235	\$166,380.00	
RGA laboratory services	8	\$1,000	\$8,000.00	12 RGA monitoring wells.
RGA driller services	1	\$117,467	\$117,467.00	12 RGA monitoring wells. RGA monitoring wells to 70ft.
LT Monitoring laboratory services	50	\$1,000	\$50,000.00	
			\$0.00	
Subtotal			\$388,819	
Material Multiplier			1.11	
<b>Total Material Charges, with Profit:</b>			<b>\$431,589</b>	

<b>Other Direct Charges</b>				
Description	Units	Rate	Cost	Comments
mailing/copying	2	\$500	\$1,000.00	
airfare	23	\$392	\$9,016.00	Columbus to Nashville.
hotel (/day)	140	\$70	\$9,800.00	
per diem	161	\$46	\$7,406.00	
car rental (/day)	84	\$91	\$7,612.92	
gas	1	\$500.00	\$500.00	Nashville to Paducah round trip + 30 mi/day; average car mileage 30 mi/gal.
			\$0.00	
Subtotal			\$35,335	
ODC Multiplier			1.11	
<b>Total Material Charges, with Profit:</b>			<b>\$39,222</b>	

<b>SUM OF GENERAL TASKS DETAILED COSTS</b>	<b>\$921,512</b>
--	------------------

15% Contingency	\$138,227
-----------------	-----------

<b>TOTAL GENERAL TASKS DETAILED COSTS</b>	<b>\$1,059,739</b>
---	--------------------

**Cost Summary Table**

Alternative 5 -In Situ Thermal Treatment and Interim Land Use Controls / C-720 Northeast

<b>Construction Costs</b>	<b>General Tasks* (Includes first 5 years of RGA groundwater sampling)</b>	<b>General Tasks (no RGA groundwater sampling)</b>
<b>\$4,217,433</b>	<b>\$921,512</b>	<b>\$752,955</b>

		<b><u>Unescalated Cost (1)</u></b>	<b><u>Escalated Cost (1)</u></b>	<b><u>Present Value (1,2)</u></b>
<b>Capital Costs</b>	(Construction Costs and General Task Costs - No RGA groundwater sampling included)	<b>\$4,970,388</b>	<b>\$5,119,500.05</b>	<b>\$4,970,388.40</b>
<b>RGA Groundwater Sampling - for first 5 years</b>		<b>\$168,557</b>	<b>\$173,613.71</b>	<b>\$168,557.00</b>
<b>RGA Groundwater Sampling Events (Years 1-30)</b>		<b>\$1,011,342.00</b>	<b>\$1,041,682.26</b>	<b>\$690,611.74</b>
<b>Total Cost</b>		<b>\$5,981,730.40</b>	<b>\$6,161,182.31</b>	<b>\$5,661,000.14</b>
<b>Total Cost with 15% Contingency</b>		<b>\$6,878,989.96</b>	<b>\$7,085,359.66</b>	<b>\$6,510,150.16</b>

1: Includes G&A and fee

2: Present worth costs are based on an assumption that outyear costs will be financed by investments made in year 0, and are provided for purposes of comparison only. Escalated costs are used by the DOE for planning and budgeting.

\*See General Tasks Price Breakdown for line items associated with costs

O&M = Operation and Maintenance

RGA = Regional Gravel Aquifer

**Los Alamos Technical Associates, Inc.**  
 DOE Document # DOE/LX/07-0362&D1  
 Alternative 5 - *In Situ* Thermal Treatment and Interim Land Use Controls Construction-Price Breakdown  
 C-720 Southeast Site

ENGINEERING LABOR							
Labor Hours/Price							Summary
Personnel	Sr Technology Leader	Sr Project Manager	Project Engineer	Engineer III/ Geologist	Engineer II	Site Sup./Health & Safety	Hours
Subtask/Rate	\$131.00	\$104.00	\$93.00	\$85.00	\$81.00	\$ 69.20	Total
ERH Construction	154.61	276.15	364.13	1289.74	110.87	543.81	2739.313333
ERH Start Up	44.17	66.35	122.67	181.39	10.89	125.87	551.3266667
ERH O&M	110.44	331.75	260.11	929.82	29.78	520.14	2182.036667
ERH Post OPS (Sampling & D&D)	88.33	1290.25	183.23	251.41	9.43	250.57	2073.226667
							0
							0
							0
Total Office Hours	397.553333	1964.5	930.1266667	2652	160.9666667	1440.39667	7546
Total Labor PRICE	\$52,079	\$204,308	\$86,502	\$225,451	\$13,038	\$99,675	<b>\$681,054</b>

FIELD LABOR							
Labor Hours/Price							Summary
Personnel	Site Sup.	Laborer 1	Laborer 2	Operator	Radcon	Escort	Hours
Subtask/Rate	\$77.83	\$61.68	\$57.33	\$57.33	\$57.33	\$ 41.10	Total
ERH Construction	191.60	224.00	1424.74	1545.84	1009.04	973.24	5368.453333
ERH Start Up	54.73			221.04	50.44	77.08	403.2966667
ERH O&M	355.19		1652.19	1243.33	63.07	385.40	3699.18
ERH Post OPS (Sampling & D&D)	204.49		663.10	275.63	100.92	77.08	1321.216667
							0
							0
Total Office Hours	806.003333	224	3740.023333	3286	1223.48	1512.79667	10792
Total Labor PRICE	\$62,731	\$13,816	\$214,416	\$188,377	\$70,142	\$62,176	<b>\$611,659</b>

MATERIAL CHARGES				
Description	Units	Rate	Cost	Comments
Materials (Construction)	0.2	\$315,000	\$63,000.00	
Materials (Start Up)	0.2	\$25,000	\$5,000.00	
Materials (O&M)	0.2	\$50,000	\$10,000.00	
Materials (Post OPS)	0.2	\$4,000	\$800.00	
			\$0.00	
Shipping	0	\$0	\$0.00	
			\$0.00	
Subtotal			\$78,800	
Material Multiplier			1.11	
<b>Total Material Charges, with Profit:</b>			<b>\$87,468</b>	

EQUIPMENT CHARGES				
Description	Units	Rate	Cost	Comments
Rental (Construction)	0.2	\$443,000	\$88,600.00	
Rental (Start Up)	0.2	\$370,000	\$74,000.00	
Rental (O&M)	0.2	\$1,860,000	\$372,000.00	
Rental (Post OPS)	0.2	\$96,000	\$19,200.00	
			\$0.00	
			\$0.00	
Subtotal			\$553,800	
Material Multiplier			1.11	
<b>Total Material Charges, with Profit:</b>			<b>\$614,718</b>	

**Los Alamos Technical Associates, Inc.**  
 DOE Document # DOE/LX/07-0362&D1  
 Alternative 5 - *In Situ* Thermal Treatment and Interim Land Use Controls Construction-Price Breakdown  
 C-720 Southeast Site

<b>SUBCONTRACTOR CHARGES</b>				
Description	Units	Rate	Cost	Comments
<b>Construction</b>				
laboratory services	0.2	\$200,000	\$40,000	
driller services	0.2	\$2,400,000	\$480,000	
USEC	0.2	\$50,000	\$10,000	
design sub	0.2	\$60,000	\$12,000	
ERH subconsultant	0.2	\$1,285,000	\$257,000	
construction subcontractor	0.2	\$500,000	\$100,000	
transportation subcontractor	0.2	\$1,780,000	\$356,000	
waste treatment	0.2	\$310,000	\$62,000	
<b>Start Up</b>				
laboratory services	0.2	\$25,000	\$5,000	
USEC	0.2	\$10,000	\$2,000	
design sub	0.2	\$10,000	\$2,000	
ERH subconsultant	0.2	\$68,000	\$13,600	
construction subcontractor	0.2	\$100,000	\$20,000	
<b>O&amp;M</b>				
laboratory services	0.2	\$200,000	\$40,000	
USEC	0.2	\$50,000	\$10,000	
ERH subconsultant	0.2	\$1,808,000	\$361,600	
<b>Post OPS (Sampling &amp; D&amp;D)</b>				
laboratory services	0.2	\$395,220	\$79,044	
ERH subconsultant	0.2	\$760,200	\$152,040	
			\$0.00	
			\$0.00	
			\$2,002,284	
			Material Multiplier	1.11
<b>Total Material Charges, with Profit:</b>				<b>\$2,222,535</b>

<b>Other Direct Charges</b>				
Description	Units	Rate	Cost	Comments
airfare		\$392	\$0.00	
hotel (/day)		\$70	\$0.00	
per diem		\$46	\$0.00	
car rental (/day)		\$91	\$0.00	
gas		\$503.00	\$0.00	
			\$0.00	
			\$0.00	
			\$0	
			ODC Multiplier	1.11
<b>Total Material Charges, with Profit:</b>				<b>\$0</b>

<b>SUM OF ERH DETAILED CONSTRUCTION COSTS</b>	<b>\$4,217,433</b>
15% Contingency	\$632,615
<b>TOTAL ERH DETAILED CONSTRUCTION COSTS</b>	<b>\$4,850,048</b>



**Los Alamos Technical Associates, Inc.**  
**DOE Document # DOE/LX/07-0362&D1**  
**C-720 Southeast Site General Tasks-Price Breakdown**

<b>ENGINEERING LABOR</b>								
Labor Hours/Price	Personnel	Sr Technology Leader	Sr Project Manager	Project Engineer	Engineer III/Geologist	Engineer II	Site Sup./Health & Safety	Summary Hours
Subtask/Rate	\$131.00	\$104.00	\$93.00	\$85.00	\$81.00	\$ 69.20		Total
Remedial Action Work Plan		45.33		62.67	47.26			155.3
Health and Safety Plan		4.67		10.00				14.7
Security Plan		2.67						2.7
QA Plan		16.67		33.02		7.80		57.5
Sampling and Analysis Plan (RDSI)		16.67		73.45				90.1
Waste Management Plan		13.33		13.33	8.47			35.1
MIP (Membrane Interface Probe) Sampling (RDSI)	14	14						28
Soil Cores (RDSI)	4	4	8					16
Data Management (RDSI)	8	8	14		268			298
Install RGA Wells (RDSI)	4	4	14		14			36
Data Management (RDSI)					28			28
Site Restoration		8						8
Monitoring/sampling (2 rounds/yr)		34	34	34				102
5 Year Reviews		28	34	80	214			356
								0
Total Office Hours	30	199.333333	104	306	579.726667	7.8033333		1072
Total Labor PRICE	\$3,930	\$20,731	\$9,672	\$26,050	\$46,958	\$540		<b>\$107,880</b>

<b>FIELD LABOR</b>								
Labor Hours/Price	Personnel	Site Sup.	Laborer 1	Laborer 2	Operator	Radcon	Escort	Summary Hours
Subtask/Rate	\$77.83	\$61.68	\$57.33	\$57.33	\$57.33	\$ 41.10		Total
MIP Sampling (RDSI)	68	68				48	48	232
Soil Cores (RDSI)	104	104				72	72	352
Install RGA Wells (RDSI)	280				280	200	200	960
Site Restoration	56		40	40	40	80		256
Monitoring/sampling	188				188	134	134	644
								0
Total Office Hours	696	172	40	508	494	534		2444
Total Labor PRICE	\$54,170	\$10,609	\$2,293	\$29,124	\$28,321	\$21,947		<b>\$146,464</b>

<b>MATERIAL CHARGES</b>				
Description	Units	Rate	Cost	Comments
Well maintenance (/well)	4	\$5,000	\$20,000.00	4 wells in each site location.
			\$0.00	
			\$20,000	
			1.11	
			<b>\$22,200</b>	

Subtotal  
Material Multiplier  
**Total Material Charges, with Profit:**

**Los Alamos Technical Associates, Inc.**  
**DOE Document # DOE/LX/07-0362&D1**  
**C-720 Southeast Site General Tasks-Price Breakdown**

<b>EQUIPMENT CHARGES</b>				
Description	Units	Rate	Cost	Comments
Interim LUCs (E/PP Program and Warning signs)	50	\$900	\$45,000.00	
DPT - samples	2120	\$40	\$84,800.00	LATA-KY baseline estimates.
Excava. permits - samples	36	\$360	\$12,960.00	LATA-KY baseline estimates.
Miscellaneous Equipment	8	\$565	\$4,520.00	
Construction trailer (/month)	1	\$2,000	\$2,000.00	Includes cost of delivery, setup, furniture rental, and return (Williams Scotsman, Inc., Hamilton, Ohio). Cost distributed between three site locations.
Change trailer (/month)	1	\$2,400	\$2,400.00	Includes cost of delivery, setup, furniture rental, and return (Williams Scotsman, Inc., Hamilton, Ohio). Cost distributed between three site locations.
Dozer (/month)	5	\$500	\$2,500.00	
Roller (/month)	5	\$500	\$2,500.00	
Seeder (/month)	1	\$218	\$218.00	
			\$0.00	
Subtotal			\$156,898	
Material Multiplier			1.11	
<b>Total Material Charges, with Profit:</b>			<b>\$174,157</b>	

<b>SUBCONTRACTOR CHARGES</b>				
Description	Units	Rate	Cost	Comments
driller services	1	\$30,334	\$30,334.00	
surveyor services	59	\$282	\$16,638.00	LATA-KY baseline estimates.
laboratory services	708	\$235	\$166,380.00	
RGA laboratory services	8	\$1,000	\$8,000.00	12 RGA monitoring wells.
RGA driller services	1	\$117,467	\$117,467.00	12 RGA monitoring wells. RGA monitoring wells to 70ft.
LT Monitoring laboratory services	50	\$1,000	\$50,000.00	
			\$0.00	
Subtotal			\$388,819	
Material Multiplier			1.11	
<b>Total Material Charges, with Profit:</b>			<b>\$431,589</b>	

<b>Other Direct Charges</b>				
Description	Units	Rate	Cost	Comments
mailing/copying	2	\$500	\$1,000.00	
airfare	23	\$392	\$9,016.00	Columbus to Nashville.
hotel (/day)	140	\$70	\$9,800.00	
per diem	161	\$46	\$7,406.00	
car rental (/day)	84	\$91	\$7,612.92	
gas	1	\$500.00	\$500.00	Nashville to Paducah round trip + 30 mi/day; average car mileage 30 mi/gal.
			\$0.00	
Subtotal			\$35,335	
ODC Multiplier			1.11	
<b>Total Material Charges, with Profit:</b>			<b>\$39,222</b>	

<b>SUM OF GENERAL TASKS DETAILED COSTS</b>	<b>\$921,512</b>
15% Contingency	\$138,227
<b>TOTAL GENERAL TASKS DETAILED COSTS</b>	<b>\$1,059,739</b>

**Cost Summary Table**

Alternative 5 -In Situ Thermal Treatment and Interim Land Use Controls / C-720 Southeast

<b>Construction Costs</b>	<b>General Tasks* (Includes first 5 years of RGA groundwater sampling)</b>	<b>General Tasks (no RGA groundwater sampling)</b>
<b>\$4,217,433</b>	<b>\$921,512</b>	<b>\$752,955</b>

	<b><u>Unescalated Cost (1)</u></b>	<b><u>Escalated Cost (1)</u></b>	<b><u>Present Value (1,2)</u></b>
<b>Capital Costs</b> (Construction Costs and General Task Costs - No RGA groundwater sampling included)	<b>\$4,970,388</b>	<b>\$5,119,500.05</b>	<b>\$4,970,388.40</b>
<b>RGA Groundwater Sampling - for first 5 years</b>	<b>\$168,557</b>	<b>\$173,613.71</b>	<b>\$168,557.00</b>
<b>RGA Groundwater Sampling Events (Years 1-30)</b>	<b>\$1,011,342.00</b>	<b>\$1,041,682.26</b>	<b>\$690,611.74</b>
<b>Total Cost</b>	<b>\$5,981,730.40</b>	<b>\$6,161,182.31</b>	<b>\$5,661,000.14</b>
<b>Total Cost with 15% Contingency</b>	<b>\$6,878,989.96</b>	<b>\$7,085,359.66</b>	<b>\$6,510,150.16</b>

1: Includes G&A and fee

2: Present worth costs are based on an assumption that outyear costs will be financed by investments made in year 0, and are provided for purposes of comparison only. Escalated costs are used by the DOE for planning and budgeting.

\*See General Tasks Price Breakdown for line items associated with costs

O&M = Operation and Maintenance

RGA = Regional Gravel Aquifer

**Los Alamos Technical Associates, Inc.**  
 DOE Document # DOE/LX/07-0362&D1  
 Alternative 5 - *In Situ* Thermal Treatment and Interim Land Use Controls Construction-Price Breakdown  
 Oil Landfarm

ENGINEERING LABOR							
Labor Hours/Price							Summary
Personnel	Sr Technology Leader	Sr Project Manager	Project Engineer	Engineer III/ Geologist	Engineer II	Site Sup./Health & Safety	Hours
Subtask/Rate	\$131.00	\$104.00	\$93.00	\$85.00	\$81.00	\$ 69.20	Total
ERH Construction	463.83	828.46	1092.38	3869.23	332.6	1631.44	8217.94
ERH Start Up	132.5	199.04	368	544.16	32.67	377.61	1653.98
ERH O&M	331.33	995.25	780.32	2789.45	89.33	1560.43	6546.11
ERH Post OPS (Sampling & D&D)	265	3870.75	549.68	754.24	28.3	751.71	6219.68
							0
							0
							0
Total Office Hours	1192.66	5893.5	2790.38	7957	482.9	4321.19	22638
Total Labor PRICE	\$156,238	\$612,924	\$259,505	\$676,352	\$39,115	\$299,026	<b>\$2,043,161</b>

FIELD LABOR							
Labor Hours/Price							Summary
Personnel	Site Sup.	Laborer 1	Laborer 2	Operator	Radcon	Escort	Hours
Subtask/Rate	\$77.83	\$61.68	\$57.33	\$57.33	\$57.33	\$ 41.10	Total
ERH Construction	574.79	672	4274.21	4637.53	3027.12	2919.71	16105.36
ERH Start Up	164.2			663.12	151.33	231.24	1209.89
ERH O&M	1065.56		4956.56	3730	189.22	1156.2	11097.54
ERH Post OPS (Sampling & D&D)	613.46		1989.3	826.88	302.77	231.24	3963.65
							0
							0
Total Office Hours	2418.01	672	11220.07	9858	3670.44	4538.39	32376
Total Labor PRICE	\$188,194	\$41,449	\$643,247	\$565,132	\$210,426	\$186,528	<b>\$1,834,976</b>

MATERIAL CHARGES				
Description	Units	Rate	Cost	Comments
Materials (Construction)	0.6	\$315,000	\$189,000.00	
Materials (Start Up)	0.6	\$25,000	\$15,000.00	
Materials (O&M)	0.6	\$50,000	\$30,000.00	
Materials (Post OPS)	0.6	\$4,000	\$2,400.00	
			\$0.00	
Shipping	0	\$0	\$0.00	
			\$0.00	
Subtotal			\$236,400	
Material Multiplier			1.11	
<b>Total Material Charges, with Profit:</b>			<b>\$262,404</b>	

EQUIPMENT CHARGES				
Description	Units	Rate	Cost	Comments
Rental (Construction)	0.6	\$443,000	\$265,800.00	
Rental (Start Up)	0.6	\$370,000	\$222,000.00	
Rental (O&M)	0.6	\$1,860,000	\$1,116,000.00	
Rental (Post OPS)	0.6	\$96,000	\$57,600.00	
			\$0.00	
			\$0.00	
Subtotal			\$1,661,400	
Material Multiplier			1.11	
<b>Total Material Charges, with Profit:</b>			<b>\$1,844,154</b>	

**Los Alamos Technical Associates, Inc.**  
 DOE Document # DOE/LX/07-0362&D1  
 Alternative 5 - *In Situ* Thermal Treatment and Interim Land Use Controls Construction-Price Breakdown  
 Oil Landfarm

<b>SUBCONTRACTOR CHARGES</b>				
Description	Units	Rate	Cost	Comments
<b>Construction</b>				
laboratory services	0.6	\$200,000	\$120,000	
driller services	0.6	\$2,400,000	\$1,440,000	
USEC	0.6	\$50,000	\$30,000	
design sub	0.6	\$60,000	\$36,000	
ERH subconsultant	0.6	\$1,285,000	\$771,000	
construction subcontractor	0.6	\$500,000	\$300,000	
transportation subcontractor	0.6	\$1,780,000	\$1,068,000	
waste treatment	0.6	\$310,000	\$186,000	
<b>Start Up</b>				
laboratory services	0.6	\$25,000	\$15,000	
USEC	0.6	\$10,000	\$6,000	
design sub	0.6	\$10,000	\$6,000	
ERH subconsultant	0.6	\$68,000	\$40,800	
construction subcontractor	0.6	\$100,000	\$60,000	
<b>O&amp;M</b>				
laboratory services	0.6	\$200,000	\$120,000	
USEC	0.6	\$50,000	\$30,000	
ERH subconsultant	0.6	\$1,808,000	\$1,084,800	
<b>Post OPS (Sampling &amp; D&amp;D)</b>				
laboratory services	0.6	\$395,220	\$237,132	
ERH subconsultant	0.6	\$760,200	\$456,120	
			\$0.00	
			\$0.00	
			\$6,006,852	
			Material Multiplier	1.11
			<b>Total Material Charges, with Profit:</b>	<b>\$6,667,606</b>

<b>Other Direct Charges</b>				
Description	Units	Rate	Cost	Comments
airfare		\$392	\$0.00	
hotel (/day)		\$70	\$0.00	
per diem		\$46	\$0.00	
car rental (/day)		\$91	\$0.00	
gas		\$503.00	\$0.00	
			\$0.00	
			\$0.00	
			\$0	
			ODC Multiplier	1.11
			<b>Total Material Charges, with Profit:</b>	<b>\$0</b>

<b>SUM OF ERH DETAILED CONSTRUCTION COSTS</b>	<b>\$12,652,300</b>
15% Contingency	\$1,897,845
<b>TOTAL ERH DETAILED CONSTRUCTION COSTS</b>	<b>\$14,550,145</b>

**Los Alamos Technical Associates, Inc.**  
**DOE Document # DOE/LX/07-0362&D1**  
**Oil Landfarm General Tasks-Price Breakdown**

<b>ENGINEERING LABOR</b>								
Labor Hours/Price	Personnel	Sr Technology Leader	Sr Project Manager	Project Engineer	Engineer III/Geologist	Engineer II	Site Sup./Health & Safety	Summary Hours
Subtask/Rate	\$131.00	\$104.00	\$93.00	\$85.00	\$81.00	\$ 69.20	Total	
Remedial Action Work Plan		136		188	141.78		465.78	
Health and Safety Plan		14		30			44	
Security Plan		8					8	
QA Plan		50		99.06		23.41	172.47	
Sampling and Analysis Plan (RDSI)		50		220.35			270.35	
Waste Management Plan		40		40	25.4		105.4	
MIP (Membrane Interface Probe) Sampling (RDSI)	14	14					28	
Soil Cores (RDSI)	4	4	8				16	
Data Management (RDSI)	8	8	14		268		298	
Install RGA Wells (RDSI)	4	4	14		14		36	
Data Management (RDSI)					28		28	
Site Restoration		8					8	
Monitoring/sampling (2 rounds/yr)		34	34	34			102	
5 Year Reviews		28	34	80	214		356	
							0	
Total Office Hours	30	398	104	691	691.18	23.41	1472	
Total Labor PRICE	\$3,930	\$41,392	\$9,672	\$58,770	\$55,986	\$1,620	<b>\$171,369</b>	

<b>FIELD LABOR</b>								
Labor Hours/Price	Personnel	Site Sup.	Laborer 1	Laborer 2	Operator	Radcon	Escort	Summary Hours
Subtask/Rate	\$77.83	\$61.68	\$57.33	\$57.33	\$57.33	\$ 41.10	Total	
MIP Sampling (RDSI)	68	68				48	48	232
Soil Cores (RDSI)	104	104				72	72	352
Install RGA Wells (RDSI)	280				280	200	200	960
Site Restoration	56		40		40	40	80	256
Monitoring/sampling	188				188	134	134	644
								0
Total Office Hours	696	172	40	508	494	534	2444	
Total Labor PRICE	\$54,170	\$10,609	\$2,293	\$29,124	\$28,321	\$21,947	<b>\$146,464</b>	

<b>MATERIAL CHARGES</b>				
Description	Units	Rate	Cost	Comments
Fill (cy)	215	\$13	\$2,792.85	
Seed (sq ft)	5810	\$0	\$23.99	
Soil Delivery (cy)	215	\$12	\$2,580.00	
Well maintenance (/well)	4	\$5,000	\$20,000.00	4 wells in each site location.
			\$0.00	
Subtotal			\$25,397	
Material Multiplier			1.11	
<b>Total Material Charges, with Profit:</b>			<b>\$28,190</b>	

**Los Alamos Technical Associates, Inc.**  
**DOE Document # DOE/LX/07-0362&D1**  
**Oil Landfarm General Tasks-Price Breakdown**

<b>EQUIPMENT CHARGES</b>				
Description	Units	Rate	Cost	Comments
Interim LUCs (E/PP Program and Warning signs)	50	\$900	\$45,000.00	
DPT - samples	2120	\$40	\$84,800.00	LATA-KY baseline estimates.
Excava. permits - samples	36	\$360	\$12,960.00	LATA-KY baseline estimates.
Miscellaneous Equipment	8	\$565	\$4,520.00	
Construction trailer (/month)	1	\$2,000	\$2,000.00	Includes cost of delivery, setup, furniture rental, and return (Williams Scotsman, Inc., Hamilton, Ohio). Cost distributed between three site locations.
Change trailer (/month)	1	\$2,400	\$2,400.00	Includes cost of delivery, setup, furniture rental, and return (Williams Scotsman, Inc., Hamilton, Ohio). Cost distributed between three site locations.
Dozer (/month)	5	\$500	\$2,500.00	
Roller (/month)	5	\$500	\$2,500.00	
Seeder (/month)	1	\$218	\$218.00	
			\$0.00	
Subtotal			\$156,898	
Material Multiplier			1.11	
<b>Total Material Charges, with Profit:</b>			<b>\$174,157</b>	

<b>SUBCONTRACTOR CHARGES</b>				
Description	Units	Rate	Cost	Comments
driller services	1	\$30,334	\$30,334.00	
surveyor services	59	\$282	\$16,638.00	LATA-KY baseline estimates.
laboratory services	708	\$235	\$166,380.00	
RGA laboratory services	8	\$1,000	\$8,000.00	12 RGA monitoring wells.
RGA driller services	1	\$117,467	\$117,467.00	12 RGA monitoring wells. RGA monitoring wells to 70ft.
LT Monitoring laboratory services	50	\$1,000	\$50,000.00	
			\$0.00	
Subtotal			\$388,819	
Material Multiplier			1.11	
<b>Total Material Charges, with Profit:</b>			<b>\$431,589</b>	

<b>Other Direct Charges</b>				
Description	Units	Rate	Cost	Comments
mailing/copying	2	\$500	\$1,000.00	
airfare	23	\$392	\$9,016.00	Columbus to Nashville.
hotel (/day)	140	\$70	\$9,800.00	
per diem	161	\$46	\$7,406.00	
car rental (/day)	84	\$91	\$7,612.92	
gas	1	\$500.00	\$500.00	Nashville to Paducah round trip + 30 mi/day; average car mileage 30 mi/gal.
			\$0.00	
Subtotal			\$35,335	
ODC Multiplier			1.11	
<b>Total Material Charges, with Profit:</b>			<b>\$39,222</b>	

<b>SUM OF GENERAL TASKS DETAILED COSTS</b>	<b>\$990,991</b>
--	------------------

15% Contingency	\$148,649
-----------------	-----------

<b>TOTAL GENERAL TASKS DETAILED COSTS</b>	<b>\$1,139,640</b>
---	--------------------

**Cost Summary Table**

Alternative 5 -In Situ Thermal Treatment and Interim Land Use Controls / Oil Landfarm

<b>Construction Costs</b>	<b>General Tasks* (Includes first 5 years of RGA groundwater sampling)</b>	<b>General Tasks (no RGA groundwater sampling)</b>
<b>\$12,652,300</b>	<b>\$990,991</b>	<b>\$822,434</b>

		<b><u>Unescalated Cost (1)</u></b>	<b><u>Escalated Cost (1)</u></b>	<b><u>Present Value (1,2)</u></b>
<b>Capital Costs</b>	(Construction Costs and General Task Costs - No RGA groundwater sampling included)	<b>\$13,474,735</b>	<b>\$13,878,976.67</b>	<b>\$13,474,734.63</b>
<b>RGA Groundwater Sampling - for first 5 years</b>		<b>\$168,557</b>	<b>\$173,613.71</b>	<b>\$168,557.00</b>
<b>RGA Groundwater Sampling Events (Years 1-30)</b>		<b>\$1,011,342.00</b>	<b>\$1,041,682.26</b>	<b>\$690,611.74</b>
<b>Total Cost</b>		<b>\$14,486,076.63</b>	<b>\$14,920,658.93</b>	<b>\$14,165,346.37</b>
<b>Total Cost with 15% Contingency</b>		<b>\$16,658,988.13</b>	<b>\$17,158,757.77</b>	<b>\$16,290,148.33</b>

1: Includes G&A and fee

2: Present worth costs are based on an assumption that outyear costs will be financed by investments made in year 0, and are provided for purposes of comparison only. Escalated costs are used by the DOE for planning and budgeting.

\*See General Tasks Price Breakdown for line items associated with costs

O&M = Operation and Maintenance

RGA = Regional Gravel Aquifer



**THIS PAGE INTENTIONALLY LEFT BLANK**

**ALTERNATIVE 6 – *IN SITU* SOURCE TREATMENT USING LIQUID  
ATOMIZED INJECTION WITH INTERIM LAND USE CONTROLS  
COSTS**

**THIS PAGE INTENTIONALLY LEFT BLANK**

**Los Alamos Technical Associates, Inc.**

DOE Document # DOE/LX/07-0362&D1

Alternative 6 - In Situ Source Treatment Using Liquid Atomized Injection with Interim Land use Controls Construction-Price Breakdown  
C-720 Northeast Site

ENGINEERING LABOR								
Labor Hours/Price	Personnel	Sr Technology Leader	Sr Project Manager	Project Engineer	Engineer III/ Geologist	Engineer II	Site Sup./Health & Safety	Summary Hours
Subtask/Rate		\$131.00	\$104.00	\$93.00	\$85.00	\$75.00	\$ 69.20	Total
Project Manager Level IV				1040				1040
Geologist Level III					1040			1040
Health & Safety Level II							1040	1040
Site Superintendent Level II							1040	1040
								0
								0
								0
Total Office Hours		0	0	1040	1040	0	2080	4160
Total Labor PRICE		\$0	\$0	\$96,720	\$88,400	\$0	\$143,936	<b>\$329,056</b>

FIELD LABOR								
Labor Hours/Price	Personnel	Site Sup.	Laborer 1	Pipe Fitter	Operator	Radcon	Escort	Summary Hours
Subtask/Rate		\$77.83	\$61.68	\$57.33	\$57.33	\$57.33	\$ 41.10	Total
Removal of piping/Laborers			80					80
Removal of piping/Fitters				80				80
Removal of piping/Operator					40			40
								0
Replacement of piping/Laborers			160					160
Replacement of piping/Fitters				160				160
Replacement of piping/Operator					80			80
2 Radcon techs for 6 months						1040		1040
4 escorts for 6 months							3120	3120
								0
Total Office Hours		0	240	240	120	1040	3120	4760
Total Labor PRICE		\$0	\$14,803	\$13,759	\$6,880	\$59,623	\$128,232	<b>\$223,297</b>

MATERIAL CHARGES				
Description	Units	Rate	Cost	Comments
Temporary decon pad and tear down	1	\$50,000	\$50,000.00	Includes construction equipment, materials, waste certification documentation and labor
Install rain gutters and downspouts on C720	1	\$6,583	\$6,582.50	555ft. (R.S. Means)
Line ditches (sf)	5860	\$1	\$6,446.00	
Place riprap (cy)	72.5	\$648	\$46,980.00	
Trenching (cy)	673	\$7	\$4,865.79	R.S. Means
Pipe-16"	22	\$4,167	\$91,674.00	FastFab Pipe, Louisville, KY
Flange-16"	23	\$647	\$14,881.00	FastFab Pipe, Louisville, KY
Pipe-10"	10	\$1,724	\$17,240.00	FastFab Pipe, Louisville, KY
Flange-10"	11	\$224	\$2,464.00	FastFab Pipe, Louisville, KY
Pipe-8"	3	\$1,638	\$4,914.00	FastFab Pipe, Louisville, KY
Flange-8"	4	\$159	\$636.00	FastFab Pipe, Louisville, KY
Concrete demo (cy)	377.5	\$125	\$47,319.63	R.S. Means
Grade and level surface (sf)	43335	\$2	\$91,003.50	R.S. Means
Place geosynthetic liner (sf)	47495	\$1	\$52,244.50	
Place asphalt	535	\$107	\$57,245.00	Central Paving, Paducah
Asphalt sealing	43335	\$0	\$7,366.95	Asphalt Maintenance, Inc.
			\$0.00	
			\$0.00	
Subtotal			\$501,863	
Material Multiplier			1.11	
<b>Total Material Charges, with Profit:</b>			<b>\$557,068</b>	

**Los Alamos Technical Associates, Inc.**  
DOE Document # DOE/LX/07-0362&D1

Alternative 6 - In Situ Source Treatment Using Liquid Atomized Injection with Interim Land use Controls Construction-Price Breakdown  
C-720 Northeast Site

<b>EQUIPMENT CHARGES</b>				
Description	Units	Rate	Cost	Comments
Construction trailer (/month)	3	\$1,000	\$3,000.00	\$1000/month Includes cost of delivery, setup, furniture rental, and return (Williams Scotsman, Inc., Hamilton, OH)
Change trailer (/month)	3	\$1,200	\$3,600.00	\$1200/month Includes cost of delivery, setup, furniture rental, and return (Williams Scotsman, Inc., Hamilton, OH)
Excavator (/month)	1	\$7,500	\$7,500.00	Sun Belt, Columbus OH
			\$0.00	
			Subtotal	\$14,100
			Material Multiplier	1.11
			<b>Total Material Charges, with Profit:</b>	<b>\$15,651</b>

<b>SUBCONTRACTOR CHARGES</b>				
Description	Units	Rate	Cost	Comments
Jet Injection Contractor	1	\$227,000	\$227,000.00	ARS Technologies, Inc.
			\$0.00	
			Subtotal	\$227,000
			Material Multiplier	1.11
			<b>Total Material Charges, with Profit:</b>	<b>\$251,970</b>

<b>Other Direct Charges</b>				
Description	Units	Rate	Cost	Comments
airfare	6	\$400	\$2,400.00	Columbus to Nashville
hotel (/day)	60	\$70	\$4,200.00	
per diem	60	\$46	\$2,760.00	
car rental (/day)	60	\$91	\$5,437.80	
gas	1	\$250	\$250.00	Nashville to Paducah round trip + 30 mi/day; average car mileage 30 mi/gal.
			\$0.00	
			\$0.00	
			Subtotal	\$15,048
			ODC Multiplier	1.11
			<b>Total Material Charges, with Profit:</b>	<b>\$16,703</b>

<b>SUM OF JET INJ. DETAILED CONSTRUCTION COSTS</b>	<b>\$1,393,745</b>
--	--------------------

15% Contingency	\$209,062
-----------------	-----------

<b>TOTAL JET INJ. DETAILED CONSTRUCTION COSTS</b>	<b>\$1,602,807</b>
---	--------------------

**Los Alamos Technical Associates, Inc.**  
**DOE Document # DOE/LX/07-0362&D1**  
**C-720 Northeast Site - General Tasks-Price Breakdown**

<b>ENGINEERING LABOR</b>							
Labor Hours/Price							Summary
Personnel	Sr Technology Leader	Sr Project Manager	Project Engineer	Engineer III/ Geologist	Engineer II	Site Sup./Health & Safety	Hours
Subtask/Rate	\$131.00	\$104.00	\$93.00	\$85.00	\$81.00	\$ 69.20	Total
Remedial Action Work Plan	70	70	140	188			468
Health and Safety Plan	14	14	34	14			76
Security Plan	8	8	28				44
QA Plan	28	28	60	80			196
Sampling and Analysis Plan (RDSI)	28	28	54	70			180
Waste Management Plan	20	20	20	40			100
MIP (Membrane Interface Probe) Sampling (RDSI)	14	14					28
Soil Cores (RDSI)	4	4	8				16
Data Management (RDSI)	8	8	14		268		298
Install RGA Wells (RDSI)	4	4	14		14		36
Data Management (RDSI)					28		28
Site Restoration		8					8
Monitoring/sampling (2 rounds/yr)		34	34	34			102
5 Year Reviews		28	34	80	214		356
							0
Total Office Hours	198	268	440	506	524	0	1936
Total Labor PRICE	\$25,938	\$27,872	\$40,920	\$43,010	\$42,444	\$0	<b>\$180,184</b>

<b>FIELD LABOR</b>							
Labor Hours/Price							Summary
Personnel	Site Sup.	Laborer 1	Laborer 2	Operator	Radcon	Escort	Hours
Subtask/Rate	\$77.83	\$61.68	\$57.33	\$57.33	\$57.33	\$ 41.10	Total
MIP Sampling (RDSI)	68	68			48	48	232
Soil Cores (RDSI)	104	104			72	72	352
Install RGA Wells (RDSI)	280			280	200	200	960
Site Restoration	56		40	40	40	80	256
Monitoring/sampling	188			188	134	134	644
							0
Total Office Hours	696	172	40	508	494	534	2444
Total Labor PRICE	\$54,170	\$10,609	\$2,293	\$29,124	\$28,321	\$21,947	<b>\$146,464</b>

<b>MATERIAL CHARGES</b>				
Description	Units	Rate	Cost	Comments
Well maintenance	4	\$5,000	\$20,000.00	4 wells in each site location.
			\$0.00	
Subtotal			\$20,000	
Material Multiplier			1.11	
<b>Total Material Charges, with Profit:</b>			<b>\$22,200</b>	

**Los Alamos Technical Associates, Inc.**  
**DOE Document # DOE/LX/07-0362&D1**  
**C-720 Northeast Site - General Tasks-Price Breakdown**

<b>EQUIPMENT CHARGES</b>				
Description	Units	Rate	Cost	Comments
Interim LUCs (E/PP Program and Warning signs)	50	\$900	\$45,000.00	
DPT - samples	2120	\$40	\$84,800.00	LATA-KY baseline estimates.
Excava. permits - samples	36	\$360	\$12,960.00	LATA-KY baseline estimates.
Miscellaneous Equipment	8	\$565	\$4,520.00	
Construction trailer (/month)	1	\$2,000	\$2,000.00	Includes cost of delivery, setup, furniture rental, and return (Williams Scotsman, Inc., Hamilton, Ohio). Cost distributed between three site locations.
Change trailer (/month)	1	\$2,400	\$2,400.00	Includes cost of delivery, setup, furniture rental, and return (Williams Scotsman, Inc., Hamilton, Ohio). Cost distributed between three site locations.
Dozer (/month)	5	\$500	\$2,500.00	
Roller (/month)	5	\$500	\$2,500.00	
Seeder (/month)	1	\$218	\$218.00	
			\$0.00	
Subtotal			\$156,898	
Material Multiplier			1.11	
<b>Total Material Charges, with Profit:</b>			<b>\$174,157</b>	

<b>SUBCONTRACTOR CHARGES</b>				
Description	Units	Rate	Cost	Comments
driller services	1	\$30,334	\$30,334.00	
surveyor services	59	\$282	\$16,638.00	LATA-KY baseline estimates.
laboratory services	708	\$235	\$166,380.00	
RGA laboratory services	8	\$1,000	\$8,000.00	12 RGA monitoring wells.
RGA driller services	1	\$117,467	\$117,467.00	12 RGA monitoring wells. RGA monitoring wells to 70ft.
LT Monitoring laboratory services	50	\$1,000	\$50,000.00	
			\$0.00	
Subtotal			\$388,819	
Material Multiplier			1.11	
<b>Total Material Charges, with Profit:</b>			<b>\$431,589</b>	

<b>Other Direct Charges</b>				
Description	Units	Rate	Cost	Comments
mailing/copying	2	\$500	\$1,000.00	
airfare	23	\$392	\$9,016.00	Columbus to Nashville
hotel (/day)	140	\$70	\$9,800.00	
per diem	161	\$46	\$7,406.00	
car rental (/day)	84	\$91	\$7,612.92	
gas	1	\$500.00	\$500.00	Nashville to Paducah round trip + 30 mi/day; average car mileage 30 mi/gal.
			\$0.00	
Subtotal			\$35,335	
ODC Multiplier			1.11	
<b>Total Material Charges, with Profit:</b>			<b>\$39,222</b>	

<b>SUM OF GENERAL TASKS DETAILED COSTS</b>	<b>\$993,816</b>
15% Contingency	\$149,072.33
<b>TOTAL GENERAL TASKS DETAILED COSTS</b>	<b>\$1,142,888</b>

**Cost Summary Table**

Alternative 6 - *In Situ* Source Treatment using Liquid Atomized Injection with Interim Land use Controls / C-720 Northeast

Construction Costs	General Tasks* (Includes first 5 years of RGA groundwater sampling)	General Tasks (no RGA groundwater sampling)
\$1,393,745	\$993,816	\$825,259

		<u>Unescalated Cost (1)</u>	<u>Escalated Cost (1)</u>	<u>Present Value (1,2)</u>
<b>Capital Costs</b>	(Construction Costs and General Task Costs - No RGA groundwater sampling included)	\$2,219,004	\$2,285,573.68	\$2,219,003.57
<b>RGA Groundwater Sampling - for first 5 years</b>		\$168,557	\$173,613.71	\$168,557.00
<b>RGA Groundwater Sampling Events (Years 1-30)</b>		\$1,011,342.00	\$1,041,682.26	\$690,611.74
<b>Total Cost</b>		\$3,230,345.57	\$3,327,255.94	\$2,909,615.31
<b>Total Cost with 15% Contingency</b>		\$3,714,897.40	\$3,826,344.33	\$3,346,057.61

1: Includes G&A and fee

2: Present worth costs are based on an assumption that outyear costs will be financed by investments made in year 0, and are provided for purposes of comparison only. Escalated costs are used by the DOE for planning and budgeting.

\*See General Tasks Price Breakdown for line items associated with costs

O&M = Operation and Maintenance

RGA = Regional Gravel Aquifer



**Los Alamos Technical Associates, Inc.**

DOE Document # DOE/LX/07-0362&D1

Alternative 6 - In Situ Source Treatment Using Liquid Atomized Injection with Interim Land use Controls Construction-Price Breakdown  
C-720 Southeast Site

ENGINEERING LABOR								
Labor Hours/Price	Personnel	Sr Technology Leader	Sr Project Manager	Project Engineer	Engineer III/ Geologist	Engineer II	Site Sup./Health & Safety	Summary Hours
Subtask/Rate		\$131.00	\$104.00	\$93.00	\$85.00	\$75.00	\$ 69.20	Total
Project Manager Level IV				1040				1040
Geologist Level III					1040			1040
Health & Safety Level II							1040	1040
Site Superintendent Level II							1040	1040
								0
								0
								0
Total Office Hours		0	0	1040	1040	0	2080	4160
Total Labor PRICE		\$0	\$0	\$96,720	\$88,400	\$0	\$143,936	\$329,056

FIELD LABOR								
Labor Hours/Price	Personnel	Site Sup.	Laborer 1	Pipe Fitter	Operator	Radcon	Escort	Summary Hours
Subtask/Rate		\$77.83	\$61.68	\$57.33	\$57.33	\$57.33	\$ 41.10	Total
Removal of piping/Laborers			80					80
Removal of piping/Fitters				80				80
Removal of piping/Operator					40			40
								0
Replacement of piping/Laborers			160					160
Replacement of piping/Fitters				160				160
Replacement of piping/Operator					80			80
2 Radcon techs for 6 months						1040		1040
4 escorts for 6 months							3120	3120
								0
Total Office Hours		0	240	240	120	1040	3120	4760
Total Labor PRICE		\$0	\$14,803	\$13,759	\$6,880	\$59,623	\$128,232	\$223,297

MATERIAL CHARGES				
Description	Units	Rate	Cost	Comments
Temporary decon pad and tear down	1	\$50,000	\$50,000.00	Includes construction equipment, materials, waste certification documentation and labor
Install rain gutters and downspouts on C720	1	\$6,583	\$6,582.50	555ft. (R.S. Means)
Line ditches	5860	\$1	\$6,446.00	
Place riprap	72.5	\$648	\$46,980.00	
Trenching	673	\$7	\$4,865.79	R.S. Means
Pipe-16"	22	\$4,167	\$91,674.00	FastFab Pipe, Louisville, KY
Flange-16"	23	\$647	\$14,881.00	FastFab Pipe, Louisville, KY
Pipe-10"	10	\$1,724	\$17,240.00	FastFab Pipe, Louisville, KY
Flange-10"	11	\$224	\$2,464.00	FastFab Pipe, Louisville, KY
Pipe-8"	3	\$1,638	\$4,914.00	FastFab Pipe, Louisville, KY
Flange-8"	4	\$159	\$636.00	FastFab Pipe, Louisville, KY
Concrete demo	377.5	\$125	\$47,319.63	R.S. Means
Grade and level surface	43335	\$2	\$91,003.50	R.S. Means
Place geosynthetic liner	47495	\$1	\$52,244.50	
Place asphalt	535	\$107	\$57,245.00	Central Paving, Paducah
Asphalt sealing	43335	\$0	\$7,366.95	Asphalt Maintenance, Inc.
			\$0.00	
			\$0.00	
			\$501,863	
			1.11	
<b>Total Material Charges, with Profit:</b>			<b>\$557,068</b>	

**Los Alamos Technical Associates, Inc.**  
DOE Document # DOE/LX/07-0362&D1

Alternative 6 - In Situ Source Treatment Using Liquid Atomized Injection with Interim Land use Controls Construction-Price Breakdown  
C-720 Southeast Site

<b>EQUIPMENT CHARGES</b>				
Description	Units	Rate	Cost	Comments
Construction trailer (/month)	3	\$1,000	\$3,000.00	\$1000/month Includes cost of delivery, setup, furniture rental, and return (Williams Scotsman, Inc., Hamilton, OH)
Change trailer (/month)	3	\$1,200	\$3,600.00	\$1200/month Includes cost of delivery, setup, furniture rental, and return (Williams Scotsman, Inc., Hamilton, OH)
Excavator (/month)	1	\$7,500	\$7,500.00	Sun Belt, Columbus OH
			\$0.00	
			Subtotal	\$14,100
			Material Multiplier	1.11
			<b>Total Material Charges, with Profit:</b>	<b>\$15,651</b>

<b>SUBCONTRACTOR CHARGES</b>				
Description	Units	Rate	Cost	Comments
Jet Injection Contractor	1	\$227,000	\$227,000.00	ARS Technologies, Inc.
			\$0.00	
			Subtotal	\$227,000
			Material Multiplier	1.11
			<b>Total Material Charges, with Profit:</b>	<b>\$251,970</b>

<b>Other Direct Charges</b>				
Description	Units	Rate	Cost	Comments
airfare	6	\$400	\$2,400.00	Columbus to Nashville
hotel (/day)	60	\$70	\$4,200.00	
per diem	60	\$46	\$2,760.00	
car rental (/day)	60	\$91	\$5,437.80	
gas	1	\$250.00	\$250.00	Nashville to Paducah round trip + 30 mi/day; average car mileage 30 mi/gal.
			\$0.00	
			\$0.00	
			Subtotal	\$15,048
			ODC Multiplier	1.11
			<b>Total Material Charges, with Profit:</b>	<b>\$16,703</b>

<b>SUM OF JET INJ. DETAILED CONSTRUCTION COSTS</b>	<b>\$1,393,745</b>
15% Contingency	\$209,062
<b>TOTAL JET INJ. DETAILED CONSTRUCTION COSTS</b>	<b>\$1,602,807</b>

**Los Alamos Technical Associates, Inc.**  
**DOE Document # DOE/LX/07-0362&D1**  
**C-720 Southeast Site General Tasks-Price Breakdown**

<b>ENGINEERING LABOR</b>							
Labor Hours/Price							Summary
Personnel	Sr Technology Leader	Sr Project Manager	Project Engineer	Engineer III/ Geologist	Engineer II	Site Sup./Health & Safety	Hours
Subtask/Rate	\$131.00	\$104.00	\$93.00	\$85.00	\$81.00	\$ 69.20	Total
Remedial Action Work Plan	70	70	140	188			468
Health and Safety Plan	14	14	34	14			76
Security Plan	8	8	28				44
QA Plan	28	28	60	80			196
Sampling and Analysis Plan (RDSI)	28	28	54	70			180
Waste Management Plan	20	20	20	40			100
MIP (Membrane Interface Probe) Sampling (RDSI)	14	14					28
Soil Cores (RDSI)	4	4	8				16
Data Management (RDSI)	8	8	14		268		298
Install RGA Wells (RDSI)	4	4	14		14		36
Data Management (RDSI)					28		28
Site Restoration		8					8
Monitoring/sampling (2 rounds/yr)		34	34	34			102
5 Year Reviews		28	34	80	214		356
							0
Total Office Hours	198	268	440	506	524	0	1936
Total Labor PRICE	\$25,938	\$27,872	\$40,920	\$43,010	\$42,444	\$0	<b>\$180,184</b>

<b>FIELD LABOR</b>							
Labor Hours/Price							Summary
Personnel	Site Sup.	Laborer 1	Laborer 2	Operator	Radcon	Escort	Hours
Subtask/Rate	\$77.83	\$61.68	\$57.33	\$57.33	\$57.33	\$ 41.10	Total
MIP Sampling (RDSI)	68	68			48	48	232
Soil Cores (RDSI)	104	104			72	72	352
Install RGA Wells (RDSI)	280			280	200	200	960
Site Restoration	56		40	40	40	80	256
Monitoring/sampling	188			188	134	134	644
							0
Total Office Hours	696	172	40	508	494	534	2444
Total Labor PRICE	\$54,170	\$10,609	\$2,293	\$29,124	\$28,321	\$21,947	<b>\$146,464</b>

<b>MATERIAL CHARGES</b>				
Description	Units	Rate	Cost	Comments
Well maintenance	4	\$5,000	\$20,000.00	4 wells in each site location.
			\$0.00	
Subtotal			\$20,000	
Material Multiplier			1.11	
<b>Total Material Charges, with Profit:</b>			<b>\$22,200</b>	

**Los Alamos Technical Associates, Inc.**  
**DOE Document # DOE/LX/07-0362&D1**  
**C-720 Southeast Site General Tasks-Price Breakdown**

<b>EQUIPMENT CHARGES</b>				
Description	Units	Rate	Cost	Comments
Interim LUCs (E/PP Program and Warning signs)	50	\$900	\$45,000.00	
DPT - samples	2120	\$40	\$84,800.00	LATA-KY baseline estimates.
Excava. permits - samples	36	\$360	\$12,960.00	LATA-KY baseline estimates.
Miscellaneous Equipment	8	\$565	\$4,520.00	
Construction trailer (/month)	1	\$2,000	\$2,000.00	Includes cost of delivery, setup, furniture rental, and return (Williams Scotsman, Inc., Hamilton, Ohio). Cost distributed between three site locations.
Change trailer (/month)	1	\$2,400	\$2,400.00	Includes cost of delivery, setup, furniture rental, and return (Williams Scotsman, Inc., Hamilton, Ohio). Cost distributed between three site locations.
Dozer (/month)	5	\$500	\$2,500.00	
Roller (/month)	5	\$500	\$2,500.00	
Seeder (/month)	1	\$218	\$218.00	
			\$0.00	
Subtotal			\$156,898	
Material Multiplier			1.11	
<b>Total Material Charges, with Profit:</b>			<b>\$174,157</b>	

<b>SUBCONTRACTOR CHARGES</b>				
Description	Units	Rate	Cost	Comments
driller services	1	\$30,334	\$30,334.00	
surveyor services	59	\$282	\$16,638.00	LATA-KY baseline estimates.
laboratory services	708	\$235	\$166,380.00	
RGA laboratory services	8	\$1,000	\$8,000.00	12 RGA monitoring wells.
RGA driller services	1	\$117,467	\$117,467.00	12 RGA monitoring wells. RGA monitoring wells to 70ft.
LT Monitoring laboratory services	50	\$1,000	\$50,000.00	
			\$0.00	
Subtotal			\$388,819	
Material Multiplier			1.11	
<b>Total Material Charges, with Profit:</b>			<b>\$431,589</b>	

<b>Other Direct Charges</b>				
Description	Units	Rate	Cost	Comments
mailing/copying	2	\$500	\$1,000.00	
airfare	23	\$392	\$9,016.00	Columbus to Nashville
hotel (/day)	140	\$70	\$9,800.00	
per diem	161	\$46	\$7,406.00	
car rental (/day)	84	\$91	\$7,612.92	
gas	1	\$500.00	\$500.00	Nashville to Paducah round trip + 30 mi/day; average car mileage 30 mi/gal.
			\$0.00	
Subtotal			\$35,335	
ODC Multiplier			1.11	
<b>Total Material Charges, with Profit:</b>			<b>\$39,222</b>	

<b>SUM OF GENERAL TASKS DETAILED COSTS</b>	<b>\$993,816</b>
--	------------------

15% Contingency	\$149,072.33
-----------------	--------------

<b>TOTAL GENERAL TASKS DETAILED COSTS</b>	<b>\$1,142,888</b>
---	--------------------

**Cost Summary Table**

Alternative 6 - *In situ* Source Treatment using Liquid Atomized Injection with Interim Land Use Controls / C-720 Southeast

Construction Costs	General Tasks* (Includes first 5 years of RGA groundwater sampling)	General Tasks (no RGA groundwater sampling)
\$1,393,745	\$993,816	\$825,259

		<u>Unescalated Cost (1)</u>	<u>Escalated Cost (1)</u>	<u>Present Value (1,2)</u>
<b>Capital Costs</b>	(Construction Costs and General Task Costs - No RGA groundwater sampling included)	\$2,219,004	\$2,285,573.68	\$2,219,003.57
<b>RGA Groundwater Sampling - for first 5 years</b>		\$168,557	\$173,613.71	\$168,557.00
<b>RGA Groundwater Sampling Events (Years 1-30)</b>		\$1,011,342.00	\$1,041,682.26	\$690,611.74
<b>Total Cost</b>		\$3,230,345.57	\$3,327,255.94	\$2,909,615.31
<b>Total Cost with 15% Contingency</b>		\$3,714,897.40	\$3,826,344.33	\$3,346,057.61

1: Includes G&A and fee

2: Present worth costs are based on an assumption that outyear costs will be financed by investments made in year 0, and are provided for purposes of comparison only. Escalated costs are used by the DOE for planning and budgeting.

\*See General Tasks Price Breakdown for line items associated with costs

O&M = Operation and Maintenance

RGA = Regional Gravel Aquifer

**ALTERNATIVE 7 - *IN SITU* SOIL FLUSHING AND SOURCE  
TREATMENT VIA MULTIPHASE EXTRACTION WITH INTERIM  
LAND USE CONTROLS**

**COSTS**

**THIS PAGE INTENTIONALLY LEFT BLANK**

**Los Alamos Technical Associates, Inc.**  
DOE Document # DOE/LX/07-0362&D1

Alternative 7 - *In situ* Soil Flushing and Source Treatment via Multiphase Extraction with Interim Land Use Controls Construction-Price Breakdown  
C-720 Northeast Site

ENGINEERING LABOR								
Labor Hours/Price	Personnel	Sr Technology Leader	Sr Project Manager	Project Engineer	Engineer III/ Geologist	Engineer II	Site Sup./Health & Safety	Summary
Subtask/Rate		\$131.00	\$104.00	\$93.00	\$85.00	\$75.00	\$ 69.20	Hours Total
Project Manager Level IV				1040				1040
Geologist Level III					1040			1040
Health & Safety Level II							1040	1040
Site Superintendent Level II							1040	1040
								0
	Total Office Hours	0	0	1040	1040	0	2080	4160
	Total Labor PRICE	\$0	\$0	\$96,720	\$88,400	\$0	\$143,936	<b>\$329,056</b>

FIELD LABOR								
Labor Hours/Price	Personnel	Site Sup.	Laborer 1	Pipe Fitter	Operator	Radcon	Escort	Summary
Subtask/Rate		\$77.83	\$61.68	\$57.33	\$57.33	\$57.33	\$ 41.10	Hours Total
Removal of piping/Laborers			80					80
Removal of piping/Fitters				80				80
Removal of piping/Operator					40			40
								0
Replacement of piping/Laborers			160					160
Replacement of piping/Fitters				160				160
Replacement of piping/Operator					80			80
								0
MPE installation/Laborer (fitter)				48				48
MPE installation/Laborer (fitter helper)				48				48
MPE installation/Laborer (electrician)			30					30
MPE installation/Laborer (electrician helper)			30					30
								0
2 Radcon techs for 6 months						1040		1040
4 escorts for 6 months							1120	1120
								0
	Total Office Hours	0	300	336	120	1040	1120	2916
	Total Labor PRICE	\$0	\$18,504	\$19,263	\$6,880	\$59,623	\$46,032	<b>\$150,302</b>



**Los Alamos Technical Associates, Inc.**  
DOE Document # DOE/LX/07-0362&D1

Alternative 7 - *In situ* Soil Flushing and Source Treatment via Multiphase Extraction with Interim Land Use Controls Construction-Price Breakdown  
C-720 Northeast Site

<b>MATERIAL CHARGES</b>				
Description	Units	Rate	Cost	Comments
Temporary decon pad and tear down	1	\$50,000	\$50,000.00	Includes construction equipment, materials, waste certification documentation and labor
Install rain gutters and downspouts on C720	1	\$6,583	\$6,582.50	555ft. (R.S. Means)
Line ditches (sf)	5860	\$1	\$6,446.00	
Place riprap (cy)	72.5	\$648	\$46,980.00	
Trenching (cy)	673	\$7	\$4,865.79	R.S. Means
Pipe-16"	22	\$4,167	\$91,674.00	FastFab Pipe, Louisville, KY
Flange-16"	23	\$647	\$14,881.00	FastFab Pipe, Louisville, KY
Pipe-10"	10	\$1,724	\$17,240.00	FastFab Pipe, Louisville, KY
Flange-10"	11	\$224	\$2,464.00	FastFab Pipe, Louisville, KY
Pipe-8"	3	\$1,638	\$4,914.00	FastFab Pipe, Louisville, KY
Flange-8"	4	\$159	\$636.00	FastFab Pipe, Louisville, KY
Concrete demo (cy)	377.5	\$125	\$47,319.63	R.S. Means
Grade and level surface (sf)	43335	\$2	\$91,003.50	R.S. Means
Place geosynthetic liner (sf)	47495	\$1	\$52,244.50	
Place asphalt	535	\$107	\$57,245.00	Central Paving, Paducah
Asphalt sealing	43335	\$0	\$7,366.95	Asphalt Maintenance, Inc.
Installation of 3 multi phase wells	180	\$300	\$54,000.00	3 multiphase wells to 60' (LATA-KY baseline estimates)
Well vaults	3	\$2,000	\$6,000.00	
2" PVC for water from wells and K.O. (ft)	350	\$1	\$434.00	McMaster-Carr
PVC fitting	1	\$105	\$105.00	
Conduit	350	\$4	\$1,515.50	3/4" waterproof flexible conduit and fittings (McMaster-Carr).
Wire	350	\$2	\$850.50	
Surfactant for injection	1	\$41,000	\$41,000.00	
			\$0.00	
Shipping	1	\$0	\$0.00	
			\$0.00	
			\$605,768	
			1.11	
			<b>\$672,402</b>	

Subtotal  
Material Multiplier  
**Total Material Charges, with Profit:**

**Los Alamos Technical Associates, Inc.**  
DOE Document # DOE/LX/07-0362&D1

Alternative 7 - *In situ* Soil Flushing and Source Treatment via Multiphase Extraction with Interim Land Use Controls Construction-Price Breakdown  
C-720 Northeast Site

<b>EQUIPMENT CHARGES</b>				
Description	Units	Rate	Cost	Comments
Construction trailer	3	\$1,000	\$3,000.00	\$1000/month Includes cost of delivery, setup, furniture rental, and return (Williams Scotsman, Inc., Hamilton, OH)
Change trailer	3	\$1,200	\$3,600.00	\$1200/month Includes cost of delivery, setup, furniture rental, and return (Williams Scotsman, Inc., Hamilton, OH)
Excavator	1	\$7,500	\$7,500.00	Sun Belt, Columbus OH
Multiphase System Trailer (Includes equipment)	1	\$100,000	\$100,000.00	ProAct, Ludington, MI
			\$0.00	
			\$0.00	
			\$114,100	
			Material Multiplier	1.11
			<b>Total Material Charges, with Profit:</b>	<b>\$126,651</b>

<b>SUBCONTRACTOR CHARGES</b>				
Description	Units	Rate	Cost	Comments
electrical subcontractor	1	\$6,000	\$6,000.00	
			\$0.00	
			\$0.00	
			\$6,000	
			Material Multiplier	1.11
			<b>Total Material Charges, with Profit:</b>	<b>\$6,660</b>

<b>Other Direct Charges</b>				
Description	Units	Rate	Cost	Comments
airfare	6	\$400	\$2,400.00	Columbus to Nashville
hotel (/day)	60	\$70	\$4,200.00	
per diem	60	\$46	\$2,760.00	
car rental (/day)	60	\$91	\$5,437.80	
gas	1	\$250	\$250.00	Nashville to Paducah round trip + 30 mi/day; average car mileage 30 mi/gal.
			\$0.00	
			\$0.00	
			\$15,048	
			ODC Multiplier	1.11
			<b>Total Material Charges, with Profit:</b>	<b>\$16,703</b>

<b>SUM OF MULTIPHASE DETAILED CONSTRUCTION COSTS</b>	<b>\$1,301,774</b>
15% Contingency	\$195,266
<b>TOTAL MULTIPHASE DETAILED CONSTRUCTION COSTS</b>	<b>\$1,497,040</b>

**Los Alamos Technical Associates, Inc.**  
DOE Document # DOE/LX/07-0362&D1

Alternative 7 - *In situ* Soil Flushing and Source Treatment via Multiphase Extraction with Interim Land Use Controls - O&M Price Breakdown  
C-720 Northeast Site

ENGINEERING LABOR							
Labor Hours/Price	Personnel						Summary
	Sr Technology Leader	Sr Project Manager	Project Engineer	Engineer III/ Geologist	Engineer II	Site Sup./Health & Safety	Hours
Subtask/Rate	\$131.00	\$104.00	\$93.00	\$85.00	\$75.00	\$ 69.20	Total
O&M Management		80					80
O&M Reporting		192					192
Sampling Reporting		384					384
							0
							0
Total Office Hours	0	656	0	0	0	0	656
Total Labor PRICE	\$0	\$68,224	\$0	\$0	\$0	\$0	<b>\$68,224</b>

FIELD LABOR							
Labor Hours/Price	Personnel						Summary
	Site Sup.	Laborer 1	Pipe Fitter	Operator	Radcon	Escort	Hours
Subtask/Rate	\$77.83	\$61.68	\$57.33	\$57.33	\$57.33	\$ 41.10	Total
							0
Sampler		576					576
Operator		5840					5840
							0
							0
Total Office Hours	0	6416	0	0	0	0	6416
Total Labor PRICE	\$0	\$395,739	\$0	\$0	\$0	\$0	<b>\$395,739</b>

MATERIAL CHARGES				
Description	Units	Rate	Cost	Comments
			\$0.00	
GAC Replacement	8	\$1,600	\$12,800.00	\$2/lb
Utilities	24	\$100	\$2,400.00	
Waste Disposal	8	\$50	\$400.00	
Sampling materials	24	\$500	\$12,000.00	
Waste Disposal Trans.	8	\$3,000	\$24,000.00	
Routine Maintenance	24	\$1,000	\$24,000.00	
	0	\$0.00	\$0.00	
Shipping	1	\$0	\$0.00	
			\$0.00	
Subtotal			\$75,600	
Material Multiplier			1.11	
<b>Total Material Charges, with Profit:</b>			<b>\$83,916</b>	

EQUIPMENT CHARGES				
Description	Units	Rate	Cost	Comments
			\$0.00	
			\$0	
Subtotal			\$0	
Material Multiplier			1.11	
<b>Total Material Charges, with Profit:</b>			<b>\$0</b>	

SUBCONTRACTOR CHARGES				
Description	Units	Rate	Cost	Comments
			\$0.00	
			\$0	
Subtotal			\$0	
Material Multiplier			1.11	
<b>Total Material Charges, with Profit:</b>			<b>\$0</b>	

**Los Alamos Technical Associates, Inc.**  
**DOE Document # DOE/LX/07-0362&D1**

**Alternative 7 - In situ Soil Flushing and Source Treatment via Multiphase Extraction with Interim Land Use Controls - O&M Price Breakdown  
 C-720 Northeast Site**

<b>Other Direct Charges</b>				
Description	Units	Rate	Cost	Comments
airfare	48	\$400	\$19,200.00	Columbus to Nashville
hotel (/day)	144	\$70	\$10,080.00	
per diem	144	\$46	\$6,624.00	
car rental (/day)	72	\$90	\$6,480.00	
gas	16	\$250	\$4,000.00	Nashville to Paducah round trip + 30 mi/day; average car mileage 30 mi/gal.
			\$0.00	
			\$0.00	
			\$46,384	
			1.11	
<i>Subtotal</i>				
<i>ODC Multiplier</i>				
<i>Total Material Charges, with Profit:</i>			<b>\$51,486</b>	

<b>SUM OF MULTIPHASE DETAILED 2 YEAR O&amp;M COSTS</b>	<b>\$599,365</b>
15% Contingency	\$89,905
<b>TOTAL MULTIPHASE DETAILED 2 YEAR O&amp;M COSTS</b>	<b>\$689,270</b>

**Los Alamos Technical Associates, Inc.**  
**DOE Document # DOE/LX/07-0362&D1**  
**C-720 Northeast Site General Tasks-Price Breakdown**

<b>ENGINEERING LABOR</b>							
Labor Hours/Price							Summary
Personnel	Sr Technology Leader	Sr Project Manager	Project Engineer	Engineer III/ Geologist	Engineer II	Site Sup./Health & Safety	Hours
Subtask/Rate	\$131.00	\$104.00	\$93.00	\$85.00	\$81.00	\$ 69.20	Total
Remedial Action Work Plan	70	70	140	188			468
Health and Safety Plan	14	14	34	14			76
Security Plan	8	8	28				44
QA Plan	28	28	60	80			196
Sampling and Analysis Plan (RDSI)	28	28	54	70			180
Waste Management Plan	20	20	20	40			100
MIP (Membrane Interface Probe) Sampling (RDSI)	14	14					28
Soil Cores (RDSI)	4	4	8				16
Data Management (RDSI)	8	8	14		268		298
Install RGA Wells (RDSI)	4	4	14		14		36
Data Management (RDSI)					28		28
Site Restoration		8					8
Monitoring/sampling (2 rounds/yr)		34	34	34			102
5 Year Reviews		28	34	80	214		356
							0
Total Office Hours	198	268	440	506	524	0	1936
Total Labor PRICE	\$25,938	\$27,872	\$40,920	\$43,010	\$42,444	\$0	<b>\$180,184</b>

<b>FIELD LABOR</b>							
Labor Hours/Price							Summary
Personnel	Site Sup.	Laborer 1	Laborer 2	Operator	Radcon	Escort	Hours
Subtask/Rate	\$77.83	\$61.68	\$57.33	\$57.33	\$57.33	\$ 41.10	Total
MIP Sampling (RDSI)	68	68			48	48	232
Soil Cores (RDSI)	104	104			72	72	352
Install RGA Wells (RDSI)	280			280	200	200	960
Site Restoration	56		40	40	40	80	256
Monitoring/sampling	188			188	134	134	644
							0
Total Office Hours	696	172	40	508	494	534	2444
Total Labor PRICE	\$54,170	\$10,609	\$2,293	\$29,124	\$28,321	\$21,947	<b>\$146,464</b>

<b>MATERIAL CHARGES</b>				
Description	Units	Rate	Cost	Comments
Well maintenance	4	\$5,000	\$20,000.00	4 wells in each site location.
			\$0.00	
			\$20,000	
			1.11	
			<b>\$22,200</b>	

Subtotal  
Material Multiplier  
**Total Material Charges, with Profit:**

**Los Alamos Technical Associates, Inc.**  
**DOE Document # DOE/LX/07-0362&D1**  
**C-720 Northeast Site General Tasks-Price Breakdown**

<b>EQUIPMENT CHARGES</b>				
Description	Units	Rate	Cost	Comments
Interim LUCs (E/PP Program and Warning signs)	50	\$900	\$45,000.00	
DPT - samples	2120	\$40	\$84,800.00	LATA-KY baseline estimates.
Excava. permits - samples	36	\$360	\$12,960.00	LATA-KY baseline estimates.
Miscellaneous Equipment	8	\$565	\$4,520.00	
Construction trailer (/month)	1	\$2,000	\$2,000.00	Includes cost of delivery, setup, furniture rental, and return (Williams Scotsman, Inc., Hamilton, Ohio). Cost distributed between three site locations.
Change trailer (/month)	1	\$2,400	\$2,400.00	Includes cost of delivery, setup, furniture rental, and return (Williams Scotsman, Inc., Hamilton, Ohio). Cost distributed between three site locations.
Dozer (/month)	5	\$500	\$2,500.00	
Roller (/month)	5	\$500	\$2,500.00	
Seeder (/month)	1	\$218	\$218.00	
			\$0.00	
Subtotal			\$156,898	
Material Multiplier			1.11	
<b>Total Material Charges, with Profit:</b>			<b>\$174,157</b>	

<b>SUBCONTRACTOR CHARGES</b>				
Description	Units	Rate	Cost	Comments
driller services	1	\$30,334	\$30,334.00	
surveyor services	59	\$282	\$16,638.00	LATA-KY baseline estimates.
laboratory services	708	\$235	\$166,380.00	
RGA laboratory services	8	\$1,000	\$8,000.00	12 RGA monitoring wells.
RGA driller services	1	\$117,467	\$117,467.00	12 RGA monitoring wells. RGA monitoring wells to 70ft.
LT Monitoring laboratory services	50	\$1,000	\$50,000.00	
			\$0.00	
Subtotal			\$388,819	
Material Multiplier			1.11	
<b>Total Material Charges, with Profit:</b>			<b>\$431,589</b>	

**Los Alamos Technical Associates, Inc.**  
**DOE Document # DOE/LX/07-0362&D1**  
**C-720 Northeast Site General Tasks-Price Breakdown**

<b>Other Direct Charges</b>				
Description	Units	Rate	Cost	Comments
mailing/copying	2	\$500	\$1,000.00	
airfare	23	\$392	\$9,016.00	Columbus to Nashville
hotel (/day)	140	\$70	\$9,800.00	
per diem	161	\$46	\$7,406.00	
car rental (/day)	84	\$91	\$7,612.92	
gas	1	\$500.00	\$500.00	Nashville to Paducah round trip + 30 mi/day; average car mileage 30 mi/gal.
			\$0.00	
Subtotal			\$35,335	
ODC Multiplier			1.11	
<i>Total Material Charges, with Profit:</i>			<b>\$39,222</b>	

<b>SUM OF GENERAL TASKS DETAILED COSTS</b>	<b>\$993,816</b>
15% Contingency	\$149,072
<b>TOTAL GENERAL TASKS DETAILED COSTS</b>	<b>\$1,142,888</b>

**Cost Summary Table**

Alternative 7 - *In situ* Soil Flushing and Source Treatment via Multiphase Extraction with Interim Land Use Controls / C-720 Northeast

Construction Costs	General Tasks* (Includes first 5 years of RGA groundwater sampling)	General Tasks (no RGA groundwater sampling)	2 yr MPE O&M	1 yr MPE O&M
\$1,301,774	\$993,816	\$825,259	\$599,365	\$299,683

		<u>Unescalated Cost (1)</u>	<u>Escalated Cost (1)</u>	<u>Present Value (1,2)</u>
<b>Capital Costs</b>	(Construction Costs and General Task Costs - No RGA groundwater sampling included)	\$2,127,033	\$2,190,843.58	\$2,127,032.60
<b>RGA Groundwater Sampling - for first 5 years</b>		\$168,557	\$173,613.71	\$168,557.00
<b>O&amp;M Years 1-2</b>	(Includes MPE system operation and RGA groundwater sampling)	\$666,788	\$686,791.56	\$641,117
<b>RGA Groundwater Sampling Events (Years 3-30)</b>		\$943,919.20	\$972,236.78	\$659,563.54
<b>Total Cost</b>		\$3,737,739.72	\$3,849,871.91	\$3,427,712.73
<b>Total Cost with 15% Contingency</b>		\$4,298,400.68	\$4,427,352.70	\$3,941,869.63

1: Includes G&A and fee

2: Present worth costs are based on an assumption that outyear costs will be financed by investments made in year 0, and are provided for purposes of comparison only. Escalated costs are used by the DOE for planning and budgeting.

\*See General Tasks Price Breakdown for line items associated with costs

MPE = Multiphase Extraction

O&M = Operation and Maintenance

RGA = Regional Gravel Aquifer



**Los Alamos Technical Associates, Inc.**  
DOE Document # DOE/LX/07-0362&D1

Alternative 7 - *In situ* Soil Flushing and Source Treatment via Multiphase Extraction with Interim Land Use Controls Construction-Price Breakdown  
C-720 Southeast Site

ENGINEERING LABOR								
Labor Hours/Price	Personnel	Sr Technology Leader	Sr Project Manager	Project Engineer	Engineer III/ Geologist	Engineer II	Site Sup./Health & Safety	Summary Hours
Subtask/Rate		\$131.00	\$104.00	\$93.00	\$85.00	\$75.00	\$ 69.20	Total
Project Manager Level IV				1040				1040
Geologist Level III					1040			1040
Health & Safety Level II							1040	1040
Site Superintendent Level II							1040	1040
								0
	Total Office Hours	0	0	1040	1040	0	2080	4160
	Total Labor PRICE	\$0	\$0	\$96,720	\$88,400	\$0	\$143,936	<b>\$329,056</b>

FIELD LABOR								
Labor Hours/Price	Personnel	Site Sup.	Laborer 1	Pipe Fitter	Operator	Radcon	Escort	Summary Hours
Subtask/Rate		\$77.83	\$61.68	\$57.33	\$57.33	\$57.33	\$ 41.10	Total
Removal of piping/Laborers			80					80
Removal of piping/Fitters				80				80
Removal of piping/Operator					40			40
								0
Replacement of piping/Laborers			160					160
Replacement of piping/Fitters				160				160
Replacement of piping/Operator					80			80
								0
MPE installation/Laborer (fitter)				48				48
MPE installation/Laborer (fitter helper)				48				48
MPE installation/Laborer (electrician)			30					30
MPE installation/Laborer (electrician helper)			30					30
								0
2 Radcon techs for 6 months						1040		1040
4 escorts for 6 months							1120	1120
								0
	Total Office Hours	0	300	336	120	1040	1120	2916
	Total Labor PRICE	\$0	\$18,504	\$19,263	\$6,880	\$59,623	\$46,032	<b>\$150,302</b>

**Los Alamos Technical Associates, Inc.**

DOE Document # DOE/LX/07-0362&D1

Alternative 7 - *In situ* Soil Flushing and Source Treatment via Multiphase Extraction with Interim Land Use Controls Construction-Price Breakdown  
C-720 Southeast Site

<b>MATERIAL CHARGES</b>				
Description	Units	Rate	Cost	Comments
Temporary decon pad and tear down	1	\$50,000	\$50,000.00	Includes construction equipment, materials, waste certification documentation and labor
Install rain gutters and downspouts on C720	1	\$6,583	\$6,582.50	555ft. (R.S. Means)
Line ditches	5860	\$1	\$6,446.00	
Place riprap	72.5	\$648	\$46,980.00	
Trenching	673	\$7	\$4,865.79	R.S. Means
Pipe-16"	22	\$4,167	\$91,674.00	FastFab Pipe, Louisville, KY
Flange-16"	23	\$647	\$14,881.00	FastFab Pipe, Louisville, KY
Pipe-10"	10	\$1,724	\$17,240.00	FastFab Pipe, Louisville, KY
Flange-10"	11	\$224	\$2,464.00	FastFab Pipe, Louisville, KY
Pipe-8"	3	\$1,638	\$4,914.00	FastFab Pipe, Louisville, KY
Flange-8"	4	\$159	\$636.00	FastFab Pipe, Louisville, KY
Concrete demo	377.5	\$125	\$47,319.63	R.S. Means
Grade and level surface	43335	\$2	\$91,003.50	R.S. Means
Place geosynthetic liner	47495	\$1	\$52,244.50	
Place asphalt	535	\$107	\$57,245.00	Central Paving, Paducah
Asphalt sealing	43335	\$0	\$7,366.95	Asphalt Maintenance, Inc.
Installation of 3 multi phase wells	180	\$300	\$54,000.00	3 wells to 60' (LATA-KY baseline estimates)
Well vaults	3	\$2,000	\$6,000.00	
2" PVC for water from wells and K.O.	350	\$1	\$434.00	McMaster-Carr
PVC fitting	1	\$105	\$105.00	
Conduit	350	\$4	\$1,515.50	3/4" waterproof flexible conduit and fittings (McMaster-Carr).
Wire	350	\$2	\$850.50	
Surfactant for injection	1	\$41,000	\$41,000.00	
			\$0.00	
Shipping	0	\$0	\$0.00	
			\$0.00	
			\$605,768	
			1.11	
<b>Total Material Charges, with Profit:</b>			<b>\$672,402</b>	

**Los Alamos Technical Associates, Inc.**  
DOE Document # DOE/LX/07-0362&D1

Alternative 7 - *In situ* Soil Flushing and Source Treatment via Multiphase Extraction with Interim Land Use Controls Construction-Price Breakdown  
C-720 Southeast Site

<b>EQUIPMENT CHARGES</b>				
Description	Units	Rate	Cost	Comments
Construction trailer	3	\$1,000	\$3,000.00	\$1000/month Includes cost of delivery, setup, furniture rental, and return (Williams Scotsman, Inc., Hamilton, OH)
Change trailer	3	\$1,200	\$3,600.00	\$1200/month Includes cost of delivery, setup, furniture rental, and return (Williams Scotsman, Inc., Hamilton, OH)
Excavator	1	\$7,500	\$7,500.00	Sun Belt, Columbus OH
Multiphase System Trailer (Includes equipment)	1	\$100,000	\$100,000.00	ProAct, Ludington, MI
			\$0.00	
			\$114,100	
			Material Multiplier	1.11
			<b>Total Material Charges, with Profit:</b>	<b>\$126,651</b>

<b>SUBCONTRACTOR CHARGES</b>				
Description	Units	Rate	Cost	Comments
electrical subcontractor	1	\$6,000	\$6,000.00	
			\$0.00	
			\$6,000	
			Material Multiplier	1.11
			<b>Total Material Charges, with Profit:</b>	<b>\$6,660</b>

<b>Other Direct Charges</b>				
Description	Units	Rate	Cost	Comments
airfare	6	\$400	\$2,400.00	Columbus to Nashville
hotel (/day)	60	\$70	\$4,200.00	
per diem	60	\$46	\$2,760.00	
car rental (/day)	60	\$91	\$5,437.80	
gas	1	\$250.00	\$250.00	Nashville to Paducah round trip + 30 mi/day; average car mileage 30 mi/gal.
			\$0.00	
			\$15,048	
			ODC Multiplier	1.11
			<b>Total Material Charges, with Profit:</b>	<b>\$16,703</b>

<b>SUM OF MULTIPHASE DETAILED CONSTRUCTION COSTS</b>	<b>\$1,301,774</b>
--	--------------------

15% Contingency	\$195,266
-----------------	-----------

<b>TOTAL MULTIPHASE DETAILED CONSTRUCTION COSTS</b>	<b>\$1,497,040</b>
---	--------------------

**Los Alamos Technical Associates, Inc.**  
DOE Document # DOE/LX/07-0362&D1

Alternative 7 - *In situ* Soil Flushing and Source Treatment via Multiphase Extraction with Interim Land Use Controls - O&M Price Breakdown  
C-720 Southeast Site

ENGINEERING LABOR							
Labor Hours/Price	Personnel						Summary
	Sr Technology Leader	Sr Project Manager	Project Engineer	Engineer III/ Geologist	Engineer II	Site Sup./Health & Safety	Hours
Subtask/Rate	\$131.00	\$104.00	\$93.00	\$85.00	\$75.00	\$ 69.20	Total
O&M Management		80					80
O&M Reporting		192					192
Sampling Reporting		384					384
							0
							0
Total Office Hours	0	656	0	0	0	0	656
Total Labor PRICE	\$0	\$68,224	\$0	\$0	\$0	\$0	<b>\$68,224</b>

FIELD LABOR							
Labor Hours/Price	Personnel						Summary
	Site Sup.	Laborer 1	Pipe Fitter	Operator	Radcon	Escort	Hours
Subtask/Rate	\$77.83	\$61.68	\$57.33	\$57.33	\$57.33	\$ 41.10	Total
							0
Sampler		576					576
Operator		5840					5840
							0
Total Office Hours	0	6416	0	0	0	0	6416
Total Labor PRICE	\$0	\$395,739	\$0	\$0	\$0	\$0	<b>\$395,739</b>

MATERIAL CHARGES				
Description	Units	Rate	Cost	Comments
			\$0.00	
GAC Replacement	8	\$1,600	\$12,800.00	\$2/lb
Utilities	24	\$100	\$2,400.00	
Waste Disposal	8	\$50	\$400.00	
Sampling materials	24	\$500	\$12,000.00	
Waste Disposal Trans.	8	\$3,000	\$24,000.00	
Routine Maintenance	24	\$1,000	\$24,000.00	
	0	\$0.00	\$0.00	
Shipping	1	\$0	\$0.00	
			\$0.00	
Subtotal			\$75,600	
Material Multiplier			1.11	
<b>Total Material Charges, with Profit:</b>			<b>\$83,916</b>	

EQUIPMENT CHARGES				
Description	Units	Rate	Cost	Comments
			\$0.00	
			\$0	
Subtotal			\$0	
Material Multiplier			1.11	
<b>Total Material Charges, with Profit:</b>			<b>\$0</b>	

SUBCONTRACTOR CHARGES				
Description	Units	Rate	Cost	Comments
			\$0.00	
			\$0	
Subtotal			\$0	
Material Multiplier			1.11	
<b>Total Material Charges, with Profit:</b>			<b>\$0</b>	

**Los Alamos Technical Associates, Inc.**  
**DOE Document # DOE/LX/07-0362&D1**

**Alternative 7 - In situ Soil Flushing and Source Treatment via Multiphase Extraction with Interim Land Use Controls - O&M Price Breakdown**  
**C-720 Southeast Site**

<b>Other Direct Charges</b>				
Description	Units	Rate	Cost	Comments
airfare	48	\$400	\$19,200.00	Columbus to Nashville
hotel (/day)	144	\$70	\$10,080.00	
per diem	144	\$46	\$6,624.00	
car rental (/day)	72	\$90	\$6,480.00	
gas	16	\$250.00	\$4,000.00	Nashville to Paducah round trip + 30 mi/day; average car mileage 30 mi/gal.
			\$0.00	
			\$0.00	
Subtotal			\$46,384	
ODC Multiplier			1.11	
<b>Total Material Charges, with Profit:</b>			<b>\$51,486</b>	

<b>SUM OF MULTIPHASE DETAILED 2 YEAR O&amp;M COSTS</b>	<b>\$599,365</b>
15% Contingency	\$89,905
<b>TOTAL MULTIPHASE DETAILED 2 YEAR O&amp;M COSTS</b>	<b>\$689,270</b>

**Los Alamos Technical Associates, Inc.**  
**DOE Document # DOE/LX/07-0362&D1**  
**C-720 Southeast Site General Tasks-Price Breakdown**

<b>ENGINEERING LABOR</b>							
Labor Hours/Price							Summary
Personnel	Sr Technology Leader	Sr Project Manager	Project Engineer	Engineer III/ Geologist	Engineer II	Site Sup./Health & Safety	Hours
Subtask/Rate	\$131.00	\$104.00	\$93.00	\$85.00	\$81.00	\$ 69.20	Total
Remedial Action Work Plan	70	70	140	188			468
Health and Safety Plan	14	14	34	14			76
Security Plan	8	8	28				44
QA Plan	28	28	60	80			196
Sampling and Analysis Plan (RDSI)	28	28	54	70			180
Waste Management Plan	20	20	20	40			100
MIP (Membrane Interface Probe) Sampling (RDSI)	14	14					28
Soil Cores (RDSI)	4	4	8				16
Data Management (RDSI)	8	8	14		268		298
Install RGA Wells (RDSI)	4	4	14		14		36
Data Management (RDSI)					28		28
Site Restoration		8					8
Monitoring/sampling (2 rounds/yr)		34	34	34			102
5 Year Reviews		28	34	80	214		356
							0
Total Office Hours	198	268	440	506	524	0	1936
Total Labor PRICE	\$25,938	\$27,872	\$40,920	\$43,010	\$42,444	\$0	<b>\$180,184</b>

<b>FIELD LABOR</b>							
Labor Hours/Price							Summary
Personnel	Site Sup.	Laborer 1	Laborer 2	Operator	Radcon	Escort	Hours
Subtask/Rate	\$77.83	\$61.68	\$57.33	\$57.33	\$57.33	\$ 41.10	Total
MIP Sampling (RDSI)	68	68			48	48	232
Soil Cores (RDSI)	104	104			72	72	352
Install RGA Wells (RDSI)	280			280	200	200	960
Site Restoration	56		40	40	40	80	256
Monitoring/sampling	188			188	134	134	644
							0
Total Office Hours	696	172	40	508	494	534	2444
Total Labor PRICE	\$54,170	\$10,609	\$2,293	\$29,124	\$28,321	\$21,947	<b>\$146,464</b>

<b>MATERIAL CHARGES</b>				
Description	Units	Rate	Cost	Comments
Well maintenance	4	\$5,000	\$20,000.00	4 wells in each site location.
			\$0.00	
Subtotal			\$20,000	
Material Multiplier			1.11	
<b>Total Material Charges, with Profit:</b>			<b>\$22,200</b>	

**Los Alamos Technical Associates, Inc.**  
**DOE Document # DOE/LX/07-0362&D1**  
**C-720 Southeast Site General Tasks-Price Breakdown**

<b>EQUIPMENT CHARGES</b>				
Description	Units	Rate	Cost	Comments
Interim LUCs (E/PP Program and Warning signs)	50	\$900	\$45,000.00	
DPT - samples	2120	\$40	\$84,800.00	LATA-KY baseline estimates.
Excava. permits - samples	36	\$360	\$12,960.00	LATA-KY baseline estimates.
Miscellaneous Equipment	8	\$565	\$4,520.00	
Construction trailer (/month)	1	\$2,000	\$2,000.00	Includes cost of delivery, setup, furniture rental, and return (Williams Scotsman, Inc., Hamilton, Ohio). Cost distributed between three site locations.
Change trailer (/month)	1	\$2,400	\$2,400.00	Includes cost of delivery, setup, furniture rental, and return (Williams Scotsman, Inc., Hamilton, Ohio). Cost distributed between three site locations.
Dozer (/month)	5	\$500	\$2,500.00	
Roller (/month)	5	\$500	\$2,500.00	
Seeder (/month)	1	\$218	\$218.00	
			\$0.00	
Subtotal			\$156,898	
Material Multiplier			1.11	
<b>Total Material Charges, with Profit:</b>			<b>\$174,157</b>	

<b>SUBCONTRACTOR CHARGES</b>				
Description	Units	Rate	Cost	Comments
driller services	1	\$30,334	\$30,334.00	
surveyor services	59	\$282	\$16,638.00	LATA-KY baseline estimates.
laboratory services	708	\$235	\$166,380.00	
RGA laboratory services	8	\$1,000	\$8,000.00	12 RGA monitoring wells.
RGA driller services	1	\$117,467	\$117,467.00	12 RGA monitoring wells. RGA monitoring wells to 70ft.
LT Monitoring laboratory services	50	\$1,000	\$50,000.00	
			\$0.00	
Subtotal			\$388,819	
Material Multiplier			1.11	
<b>Total Material Charges, with Profit:</b>			<b>\$431,589</b>	

**Los Alamos Technical Associates, Inc.**  
**DOE Document # DOE/LX/07-0362&D1**  
**C-720 Southeast Site General Tasks-Price Breakdown**

<b>Other Direct Charges</b>				
Description	Units	Rate	Cost	Comments
mailing/copying	2	\$500	\$1,000.00	
airfare	23	\$392	\$9,016.00	Columbus to Nashville
hotel (/day)	140	\$70	\$9,800.00	
per diem	161	\$46	\$7,406.00	
car rental (/day)	84	\$91	\$7,612.92	
gas	1	\$500.00	\$500.00	Nashville to Paducah round trip + 30 mi/day; average car mileage 30 mi/gal.
			\$0.00	
Subtotal			\$35,335	
ODC Multiplier			1.11	
<i>Total Material Charges, with Profit:</i>			<b>\$39,222</b>	

<b>SUM OF GENERAL TASKS DETAILED COSTS</b>	<b>\$993,816</b>
15% Contingency	\$149,072
<b>TOTAL GENERAL TASKS DETAILED COSTS</b>	<b>\$1,142,888</b>



**Cost Summary Table**

Alternative 7 - In situ Soil Flushing and Source Treatment via Multiphase Extraction with Interim Land Use Controls / C-720 Southeast

Construction Costs	General Tasks* (Includes first 5 years of RGA groundwater sampling)	General Tasks (no RGA groundwater sampling)	2 yr MPE O&M	1 yr MPE O&M
\$1,301,774	\$993,816	\$825,259	\$599,365	\$299,683

		<u>Unescalated Cost (1)</u>	<u>Escalated Cost (1)</u>	<u>Present Value (1,2)</u>
<b>Capital Costs</b>	(Construction Costs and General Task Costs - No RGA groundwater sampling included)	\$2,127,033	\$2,190,843.58	\$2,127,032.60
<b>RGA Groundwater Sampling - for first 5 years</b>		\$168,557	\$173,613.71	\$168,557.00
<b>O&amp;M Years 1-2</b>	(Includes MPE system operation and RGA groundwater sampling)	\$666,788	\$686,791.56	\$641,117
<b>RGA Groundwater Sampling Events (Years 3-30)</b>		\$943,919.20	\$972,236.78	\$659,563.54
<b>Total Cost</b>		\$3,737,739.72	\$3,849,871.91	\$3,427,712.73
<b>Total Cost with 15% Contingency</b>		\$4,298,400.68	\$4,427,352.70	\$3,941,869.63

1: Includes G&A and fee

2: Present worth costs are based on an assumption that outyear costs will be financed by investments made in year 0, and are provided for purposes of comparison only. Escalated costs are used by the DOE for planning and budgeting.

\*See General Tasks Price Breakdown for line items associated with costs

MPE = Multiphase Extraction

O&M = Operation and Maintenance

RGA = Regional Gravel Aquifer

**ALTERNATIVE 8 - *IN SITU* SOURCE TREATMENT USING  
ENHANCED *IN SITU* BIOREMEDIATION WITH INTERIM LAND  
USE CONTROLS**

**COSTS**

**THIS PAGE INTENTIONALLY LEFT BLANK**

**Los Alamos Technical Associates, Inc.**

DOE Document # DOE/LX/07-0362&D1

Alternative 8 In Situ Treatment Using Enhanced In Situ Bioremediation with Interim Land Use Controls Construction-Price Breakdown  
Oil Landfarm

ENGINEERING LABOR								
Labor Hours/Price							Summary	
	Personnel	Sr Technology Leader	Sr Project Manager	Project Engineer	Engineer III/ Geologist	Engineer II	Site Sup./Health & Safety	Hours
Subtask/Rate		\$131.00	\$104.00	\$93.00	\$85.00	\$75.00	\$ 69.20	Total
Project Manager Level IV				1040				1040
Geologist Level III					1040			1040
Health & Safety Level II							1040	1040
Site Superintendent Level II							1040	1040
								0
								0
								0
Total Office Hours		0	0	1040	1040	0	2080	4160
Total Labor PRICE		\$0	\$0	\$96,720	\$88,400	\$0	\$143,936	<b>\$329,056</b>

FIELD LABOR								
Labor Hours/Price							Summary	
	Personnel	Site Sup.	Laborer 1	Laborer 2	Operator	Radcon	Escort	Hours
Subtask/Rate		\$77.83	\$61.68	\$57.33	\$57.33	\$57.33	\$ 41.10	Total
Laborer			1040					1040
Operator					1040			1040
Pipe fitter			1040					1040
2 Radcon techs for 6 months						1040		1040
4 escorts for 6 months							2000	2000
Total Office Hours		0	2080	0	1040	1040	2000	6160
Total Labor PRICE		\$0	\$128,294	\$0	\$59,623	\$59,623	\$82,200	<b>\$329,741</b>

MATERIAL CHARGES				
Description	Units	Rate	Cost	Comments
Temporary decon pad and tear down	1	\$50,000	\$50,000.00	Includes construction equipment, materials, waste certification documentation and labor
Place riprap	72.5	\$648	\$46,980.00	
Tilling Surface (cy)	673	\$7	\$4,865.79	R.S. Means
bio reagent	410,000	\$1	\$574,000.00	assumes lactate reductant
bio delivery equipment	47,870	\$1	\$47,870.00	Pro-Act Trailer mounted
Pipe for Herring Bone	1000	\$3	\$2,500.00	
Fittings for Herring Bone	50	\$25	\$1,250.00	
gravel fill for Herring Bone (cy)	834	\$25	\$20,850.00	
Grade and level surface	43335	\$2	\$91,003.50	
Place geosynthetic liner	0	\$1	\$0.00	
Installation of 6 multi phase wells (deep)	360	\$300	\$108,000.00	6 wells to 60'.
Well vaults	12	\$2,000	\$24,000.00	
Installation of 6 multi phase wells (shallow)	240	\$300	\$72,000.00	6 wells to 40'.
diesel (gal)	500	\$3	\$1,500.00	
	0		\$0.00	
Shipping	1	\$0	\$0.00	
			\$0.00	
Subtotal			\$1,044,819	
Material Multiplier			1.11	
<b>Total Material Charges, with Profit:</b>			<b>\$1,159,749</b>	

**Los Alamos Technical Associates, Inc.**

DOE Document # DOE/LX/07-0362&D1

Alternative 8 In Situ Treatment Using Enhanced In Situ Bioremediation with Interim Land Use Controls Construction-Price Breakdown  
Oil Landfarm

<b>EQUIPMENT CHARGES</b>				
Description	Units	Rate	Cost	Comments
Construction trailer (/month)	3	\$1,000	\$3,000.00	\$1000/month Includes cost of delivery, setup, furniture rental, and return (Williams Scotsman, Inc., Hamilton, OH)
Change trailer (/month)	3	\$1,200	\$3,600.00	\$1200/month Includes cost of delivery, setup, furniture rental, and return (Williams Scotsman, Inc., Hamilton, OH)
Excavator (/month)	1.5	\$7,500	\$11,250.00	Sun Belt, Columbus OH
Bulldozer (/month)	1.5	\$7,500	\$11,250.00	
			\$0.00	
			\$0.00	
Subtotal			\$29,100	
Material Multiplier			1.11	
<b>Total Material Charges, with Profit:</b>			<b>\$32,301</b>	

<b>SUBCONTRACTOR CHARGES</b>				
Description	Units	Rate	Cost	Comments
	0	\$0.00	\$0.00	
			\$0	
Subtotal			\$0	
Material Multiplier			1.11	
<b>Total Material Charges, with Profit:</b>			<b>\$0</b>	

<b>Other Direct Charges</b>				
Description	Units	Rate	Cost	Comments
airfare	6	\$400	\$2,400.00	Columbus to Nashville
hotel (/day)	60	\$70	\$4,200.00	
per diem	60	\$46	\$2,760.00	
car rental (/day)	60	\$91	\$5,437.80	
gas	1	\$250	\$250.00	Nashville to Paducah round trip + 30 mi/day; average car mileage 30 mi/gal.
			\$0.00	
			\$0.00	
Subtotal			\$15,048	
ODC Multiplier			1.11	
<b>Total Material Charges, with Profit:</b>			<b>\$16,703</b>	

<b>SUM OF BIO DETAILED CONSTRUCTION COSTS</b>	<b>\$1,867,550</b>
---	--------------------

25% Contingency	\$466,887.57
-----------------	--------------

<b>TOTAL BIO DETAILED CONSTRUCTION COSTS</b>	<b>\$2,334,438</b>
--	--------------------

**Los Alamos Technical Associates, Inc.**

DOE Document # DOE/LX/07-0362&D1

Alternative 8 In Situ Treatment Using Enhanced In Situ Bioremediation with Interim Land Use Controls O&M-Price Breakdown  
Oil Landfarm

ENGINEERING LABOR							
Labor Hours/Price							Summary
Personnel	Sr Technology Leader	Sr Project Manager	Project Engineer	Engineer III/ Geologist	Engineer II	Site Sup./Health & Safety	Hours
Subtask/Rate	\$131.00	\$104.00	\$93.00	\$85.00	\$75.00	\$ 69.20	Total
Reporting		32					32
							0
Total Office Hours	0	32	0	0	0	0	32
Total Labor PRICE	\$0	\$3,328	\$0	\$0	\$0	\$0	<b>\$3,328</b>

FIELD LABOR							
Labor Hours/Price							Summary
Personnel	Site Sup.	Laborer 1	Laborer 2	Operator	Radcon	Escort	Hours
Subtask/Rate	\$77.83	\$61.68	\$57.33	\$57.33	\$57.33	\$ 41.10	Total
Treatment Plant Operator		240					240
Sampling			144				144
							0
							0
Total Office Hours	0	240	144	0	0	0	384
Total Labor PRICE	\$0	\$14,803	\$8,256	\$0	\$0	\$0	<b>\$23,059</b>

MATERIAL CHARGES				
Description	Units	Rate	Cost	Comments
bio reagent	38,733	\$22	\$836,632.80	
			\$0.00	
Shipping	1	\$0	\$0.00	
			\$0.00	
Subtotal			\$836,633	
Material Multiplier			1.11	
<b>Total Material Charges, with Profit:</b>			<b>\$928,662</b>	

EQUIPMENT CHARGES				
Description	Units	Rate	Cost	Comments
			\$0.00	
Sampling costs	24	\$500	\$12,000.00	
			\$0.00	
Subtotal			\$12,000	
Material Multiplier			1.11	
<b>Total Material Charges, with Profit:</b>			<b>\$13,320</b>	

SUBCONTRACTOR CHARGES				
Description	Units	Rate	Cost	Comments
	0	\$0.00	\$0.00	
			\$0.00	
Subtotal			\$0	
Material Multiplier			1.11	
<b>Total Material Charges, with Profit:</b>			<b>\$0</b>	

**Los Alamos Technical Associates, Inc.**

DOE Document # DOE/LX/07-0362&D1

Alternative 8 In Situ Treatment Using Enhanced In Situ Bioremediation with Interim Land Use Controls O&M-Price Breakdown  
Oil Landfarm

Other Direct Charges				
Description	Units	Rate	Cost	Comments
airfare	18	\$400	\$7,200.00	Columbus to Nashville
hotel (/day)	90	\$70	\$6,300.00	
per diem	90	\$46	\$4,140.00	
car rental (/day)	45	\$91	\$4,078.35	
gas	9	\$250.00	\$2,250.00	Nashville to Paducah round trip + 30 mi/day; average car mileage 30 mi/gal.
			\$0.00	
			\$0.00	
Subtotal			\$23,968	
ODC Multiplier			1.11	
<i>Total Material Charges, with Profit:</i>			<b>\$26,605</b>	

<b>SUM OF BIO DETAILED 2 YEAR O&amp;M COSTS</b>	<b>\$994,974</b>
25% Contingency	\$248,743.50
<b>TOTAL BIO DETAILED 2 YEAR O&amp;M COSTS</b>	<b>\$1,243,717</b>

**Los Alamos Technical Associates, Inc.**  
 DOE Document # DOE/LX/07-0362@D1  
 Oil Landfarm General Tasks-Price Breakdown

<b>ENGINEERING LABOR</b>							
Labor Hours/Price							Summary
Personnel	Sr Technology Leader	Sr Project Manager	Project Engineer	Engineer III/ Geologist	Engineer II	Site Sup./Health & Safety	Hours
Subtask/Rate	\$131.00	\$104.00	\$93.00	\$85.00	\$81.00	\$ 69.20	Total
Remedial Action Work Plan	70	70	140	188			468
Health and Safety Plan	14	14	34	14			76
Security Plan	8	8	28				44
QA Plan	28	28	60	80			196
Sampling and Analysis Plan (RDSI)	28	28	54	70			180
Waste Management Plan	20	20	20	40			100
MIP (Membrane Interface Probe) Sampling (RDSI)	14	14					28
Soil Cores (RDSI)	4	4	8				16
Data Management (RDSI)	8	8	14		268		298
Install RGA Wells (RDSI)	4	4	14		14		36
Data Management (RDSI)					28		0
Site Restoration		8					8
Monitoring/sampling (2 rounds/yr)		34	34	34			102
5 Year Reviews		28	34	80	214		356
							0
Total Office Hours	198	268	440	506	524	0	1440
Total Labor PRICE	\$25,938	\$27,872	\$40,920	\$43,010	\$42,444	\$0	<b>\$180,184</b>

<b>FIELD LABOR</b>							
Labor Hours/Price							Summary
Personnel	Site Sup.	Laborer 1	Laborer 2	Operator	Radcon	Escort	Hours
Subtask/Rate	\$77.83	\$61.68	\$57.33	\$57.33	\$57.33	\$ 41.10	Total
MIP Sampling (RDSI)	68	68			48	48	232
Soil Cores (RDSI)	104	104			72	72	352
Install RGA Wells (RDSI)	280			280	200	200	960
Site Restoration	56		40	40	40	80	256
Monitoring/sampling	188			188	134	134	644
							0
Total Office Hours	696	172	40	508	494	534	2444
Total Labor PRICE	\$54,170	\$10,609	\$2,293	\$29,124	\$28,321	\$21,947	<b>\$146,464</b>



**Los Alamos Technical Associates, Inc.**  
**DOE Document # DOE/LX/07-0362@D1**  
**Oil Landfarm General Tasks-Price Breakdown**

<b>MATERIAL CHARGES</b>				
Description	Units	Rate	Cost	Comments
Fill (cy)	215	\$13	\$2,792.85	
Seed (sq ft)	5810	\$0	\$23.99	
Soil Delivery (cy)	215	\$12	\$2,580.00	
Well maintenance	4	\$5,000	\$20,000.00	4 wells in each site location.
			\$0.00	
			Subtotal	
			\$25,397	
			Material Multiplier	
			1.11	
			<b>Total Material Charges, with Profit:</b>	
			<b>\$28,190</b>	

<b>EQUIPMENT CHARGES</b>				
Description	Units	Rate	Cost	Comments
Interim LUCs (E/PP Program and Warning signs)	50	\$900	\$45,000.00	
DPT - samples	2120	\$40	\$84,800.00	LATA-KY baseline estimates.
Excava. permits - samples	36	\$360	\$12,960.00	LATA-KY baseline estimates.
Miscellaneous Equipment	8	\$565	\$4,520.00	
Construction trailer (/month)	1	\$2,000	\$2,000.00	Includes cost of delivery, setup, furniture rental, and return (Williams Scotsman, Inc., Hamilton, Ohio). Cost distributed between three site locations.
Change trailer (/month)	1	\$2,400	\$2,400.00	Includes cost of delivery, setup, furniture rental, and return (Williams Scotsman, Inc., Hamilton, Ohio). Cost distributed between three site locations.
Dozer (/month)	5	\$500	\$2,500.00	
Roller (/month)	5	\$500	\$2,500.00	
Seeder (/month)	1	\$218	\$218.00	
			\$0.00	
			Subtotal	
			\$156,898	
			Material Multiplier	
			1.11	
			<b>Total Material Charges, with Profit:</b>	
			<b>\$174,157</b>	

**Los Alamos Technical Associates, Inc.**  
 DOE Document # DOE/LX/07-0362@D1  
 Oil Landfarm General Tasks-Price Breakdown

<b>SUBCONTRACTOR CHARGES</b>				
Description	Units	Rate	Cost	Comments
driller services	1	\$30,334	\$30,334.00	
surveyor services	59	\$282	\$16,638.00	LATA-KY baseline estimates.
laboratory services	708	\$235	\$166,380.00	
RGA laboratory services	8	\$1,000	\$8,000.00	12 RGA monitoring wells.
RGA driller services	1	\$117,467	\$117,467.00	12 RGA monitoring wells. RGA monitoring wells to 70ft.
LT Monitoring laboratory services	50	\$1,000	\$50,000.00	
			\$0.00	
Subtotal			\$388,819	
Material Multiplier			1.11	
<b>Total Material Charges, with Profit:</b>			<b>\$431,589</b>	

<b>Other Direct Charges</b>				
Description	Units	Rate	Cost	Comments
mailing/copying	2	\$500	\$1,000.00	
airfare	23	\$392	\$9,016.00	Columbus to Nashville
hotel (/day)	140	\$70	\$9,800.00	
per diem	161	\$46	\$7,406.00	
car rental (/day)	84	\$91	\$7,612.92	
gas	1	\$500.00	\$500.00	Nashville to Paducah round trip + 30 mi/day; average car mileage 30 mi/gal.
			\$0.00	
Subtotal			\$35,335	
ODC Multiplier			1.11	
<b>Total Material Charges, with Profit:</b>			<b>\$39,222</b>	

<b>SUM OF GENERAL TASKS DETAILED COSTS</b>	<b>\$999,806</b>
25% Contingency	\$249,951.51
<b>TOTAL GENERAL TASKS DETAILED COSTS</b>	<b>\$1,249,758</b>

**Cost Summary Table**

Alternative 8 *In Situ* Treatment Using Enhanced *In Situ* Bioremediation with Interim Land Use Controls / Oil Landfarm

Construction Costs	General Tasks* (Includes first 5 years of RGA groundwater sampling)	General Tasks (no RGA groundwater sampling)	2 yr O&M	1 yr O&M
\$1,867,550	\$999,806	\$831,249	\$994,974	\$497,487.00

	<u>Unescalated Cost (1)</u>	<u>Escalated Cost (1)</u>	<u>Present Value (1,2)</u>
<b>Total Construction Costs</b> (Tech Costs + Gen Tasks - 5 yrO&M=)	\$2,698,799	\$2,779,763.27	\$2,698,799.29
<b>RGA Groundwater Sampling - for first 5 years</b>	\$168,557	\$173,613.71	\$168,557.00
<b>O&amp;M Years 1-2</b>	\$1,062,397	\$1,094,268.70	\$1,021,494.52
<b>RGA Groundwater Sampling Events (Years 3-30)</b>	\$943,919	\$972,236.78	\$659,563.54
<b>Total O&amp;M</b>	\$2,006,316.00	\$2,066,505.48	\$1,681,058.06
<b>Total Cost</b>	\$4,705,115.29	\$4,846,268.75	\$4,379,857.35
<b>Total Cost with 15% Contingency</b>	\$5,881,394.11	\$6,057,835.94	\$5,474,821.69

1: Includes G&A and fee

2: Present worth costs are based on an assumption that outyear costs will be financed by investments made in year 0, and are provided for purposes of comparison only. Escalated costs are used by the DOE for planning and budgeting.

\*See General Tasks Price Breakdown for line items associated with costs

O&M = Operation and Maintenance

RGA = Regional Gravel Aquifer

**APPENDIX C**

**SOUTHWEST PLUME FOCUSED FEASIBILITY SESOIL, AT123D,  
AND DILUTION ATTENUATION FACTOR MODELING**

**THIS PAGE INTENTIONALLY LEFT BLANK**

# CONTENTS

TABLES .....	C-5
FIGURES .....	C-5
ACRONYMS .....	C-7
C.1. INTRODUCTION.....	C-9
C.2. CONTINENTAL RECHARGE SYSTEM AND REGIONAL GRAVEL AQUIFER HYDROSTRATIGRAPHY .....	C-10
C.3 SESOIL AND AT123D MODELING AND DAF CALCULATIONS .....	C-15
C.4 UNCERTAINTY ANALYSIS.....	C-26
C.4.1 SITE CONCEPTUAL MODEL UNCERTAINTY .....	C-27
C.4.2. TCE RG PROBABILISTIC MODELING.....	C-28
C.4.3 SWMU 1 TCE RESULTS .....	C-28
C.4.4 C-720 TCE RESULTS .....	C-34
C.5 SUMMARY AND CONCLUSIONS.....	C-35
C.6 REFERENCES.....	C-35

**THIS PAGE INTENTIONALLY LEFT BLANK**

## TABLES

C.1.	Expected Remedial Effectiveness.....	C-9
C.2.	HU3/HU4 Contact at SWMU 1 .....	C-11
C.3.	HU3/HU4 Contact at C-720.....	C-11
C.4.	Soil Parameters Used in SESOIL Modeling of SWMU 1 and the C-720 Building Area .....	C-15
C.5.	Chemical-Specific Parameters of the Contaminants of Concern Used in SESOIL Modeling .....	C-15
C.6.	Summary of Source Term Characteristics for SWMU 1 .....	C-16
C.7.	Summary of Source Term Characteristics for the C-720 Building Area Source .....	C-167
C.8.	Hydrogeologic Parameters Used in AT123D Modeling.....	C-18
C.9.	SWMU 1 Parameter Values for Calculation of the DAF.....	C-20
C.10.	C-720 Parameter Values for Calculation of the DAF .....	C-20
C.11.	Expected Posttreatment Average TCE Concentrations by Layer for SWMU 1 .....	C-21
C.12.	Expected Time Frames to Reach TCE MCL in the RGA at SWMU 1.....	C-22
C.13.	SWMU 1 Soil Remediation Goals for Groundwater Based on a DAF.....	C-24
C.14.	Expected Posttreatment Average TCE Concentrations by Layer for C-720.....	C-24
C.15.	Expected Time Frames to Reach TCE MCL in the RGA at C-720.....	C-25
C.16.	C-720 Soil Remediation Goals for Groundwater Based on a DAF .....	C-26
C.17.	SWMU 1 SESOIL Input Parameters Used in Probabilistic Modeling .....	C-29
C.18.	C-720 SESOIL Input Parameters Used in Probabilistic Modeling .....	C-31
C.19.	SWMU 1 TCE Remediation Goals Based on the 75% Quartile, Mean, Median, Geometric Mean, and 25% Quartile for Statistical Parameters Evaluated for the Maximum Groundwater Concentrations.....	C-33
C.20.	C-720 TCE Remediation Goals Based on the 75% Quartile, Mean, Median, Geometric Mean, and 25% Quartile for Statistical Parameters Evaluated for the Maximum Groundwater Concentrations .....	C-34

## FIGURES

C.1.	Geologic Cross Section A-A' at SWMU 1 .....	C-13
C.2.	Geologic Cross Section B-B' at SWMU 1.....	C-14
C.3.	Time Required for Residual TCE Mass from SWMU 1 to Reach MCL (5 µg/L) in RGA .....	C-21
C.4.	Time Required for Residual TCE Mass from SWMU 1 to Reach MCL (5 µg/L) in RGA for Large Diameter Auger Excavation.....	C-22
C.5.	Time Required for Residual <i>cis</i> -DCE and <i>trans</i> -DCE Mass from SWMU 1 to Reach MCLs in RGA.....	C-23
C.6.	Time Required for Residual TCE Mass from C-720 to Reach MCL (5 µg/L) in RGA .....	C-25
C.7.	Time Required for Residual <i>cis</i> -DCE, <i>trans</i> -DCE, and VC Mass from C-720 to Reach MCLs in RGA.....	C-26
C.8.	Histogram of SWMU 1 TCE RGs Based on the Maximum Predicted TCE Groundwater Concentrations .....	C-33
C.9.	Histogram of C-720 TCE RGs Based on the Maximum Predicted TCE Groundwater Concentrations .....	C-34



**THIS PAGE INTENTIONALLY LEFT BLANK**

## ACRONYMS

AT123D	Analytical Transport 1-, 2-, 3-Dimensional
COC	contaminant of concern
CRS	Continental Recharge System
DAF	dilution attenuation factor
DCE	dichloroethene
HU	hydrologic unit
$K_{oc}$	organic carbon partition coefficient
$K_d$	distribution coefficient
LCRS	Lower Continental Recharge System
MCL	maximum contaminant level
NE	northeast
PGDP	Paducah Gaseous Diffusion Plant
RG	remediation goal
RGA	Regional Gravel Aquifer
SE	southeast
SESOIL	Seasonal Soil Compartment
SI	site investigation
SWMU	solid waste management unit
TCE	trichloroethene
UCRS	Upper Continental Recharge System
VC	vinyl chloride
VOC	volatile organic compound

**THIS PAGE INTENTIONALLY LEFT BLANK**

## C.1. INTRODUCTION

Seasonal Soil Compartment (SESOIL) and Analytical Transport 1-, 2-, 3-Dimensional (AT123D) modeling were coupled together to determine the effects of systematic reductions of Solid Waste Management Unit (SWMU) 1 and C-720 Building Upper Continental Recharge System (UCRS) volatile organic compound (VOC) soil contaminant concentrations [i.e., trichloroethene (TCE), *cis*- and *trans*-1,2-dichloroethene (DCE), vinyl chloride (VC), and 1,1-DCE (hereafter referred to as collectively as “soil contaminants” unless otherwise noted)] on underlying Regional Gravel Aquifer (RGA) groundwater quality, specifically the time required for RGA groundwater contaminant concentrations to drop below maximum contaminant levels (MCLs). Systematic reduction evaluation was performed in recognition that there are a number of potentially viable remedial alternatives for soil cleanup applicable to the UCRS having varying effectiveness in reducing soil contaminant concentrations. Similarly, there are a range of possible biological half-lives for TCE in the RGA (5 to 50 years). In addition, as an alternative to the SESOIL and AT123D modeling, dilution attenuation factor (DAF) calculations were performed to determine the maximum bulk UCRS soil contamination concentrations that could remain and still be protective of RGA groundwater quality.

Remedial technologies evaluated for SWMU 1 and C-720 Building soil contamination cleanup via SESOIL/AT123D modeling and DAF calculations include the following:

- Deep Soil Mixing with Enhancements,
- Large Diameter Auger Excavation with Deep *In situ* Treatment,
- *In situ* Thermal Treatment,
- *In situ* Jet Chemical Source Treatment,
- *In situ* Soil Flushing with Dual-Phase Extraction, and
- Enhanced *In situ* Bioremediation.

Details regarding remedial technology specifics can be found in the body of this Southwest Plume Focused Feasibility Study. The range of estimated treatment efficiencies to achieve soil contaminant concentration reductions for the listed remedial technologies is summarized in Table C.1. The estimated treatment efficiency represents the reduction in contaminant concentration as a result of active treatment. In the case of long-term monitoring, no active treatment is included and the estimated treatment efficiency is 0%.

**Table C.1. Expected Remedial Effectiveness**

<b>Remedial Technology</b>	<b>Estimated Treatment Efficiency, %</b>
Deep Soil Mixing with Enhancements	91
Large Diameter Auger Excavation with Deep <i>In situ</i> Treatment	100% in excavated portion of soil column, 0% in underlying untreated native soil
<i>In situ</i> ERH Treatment	98
<i>In situ</i> LAI Source Treatment	90
<i>In situ</i> Soil Flushing with Multiphase Extraction	95
Enhanced <i>In situ</i> Bioremediation	60
Long-term Monitoring	0

ERH = electrical resistance heating

LAI = liquid atomized injection

SESOIL is a one-dimensional, unsaturated (vadose) zone, vertical transport screening-level model that simulates the temporal reduction of soil contaminant concentrations as a result of advection, diffusion, adsorption, volatilization, and biodegradation and calculates the temporal effect of these processes on

groundwater concentrations at the bottom of the UCRS. Because SESOIL is a screening-level model, the code is incapable of simulating the actual physics of the remedial technologies. Rather, SESOIL remedial evaluation assumes that the initial soil contaminant concentrations correspond to those present at the conclusion of remediation. For example, if a remedial technology is assumed to be 75% effective in reducing soil contaminant concentrations, soil contaminant input concentrations for the SESOIL remedial evaluations would be specified as 25% of the characterized preremedial concentrations. It also should be noted that SESOIL is a vadose zone code capable of simulating varying degrees of saturation, including complete saturation. This is because output from the SESOIL model is temporal contaminant mass loading rate (the input for AT123D) that is controlled by the simulated infiltration rate, in addition to advection, diffusion, adsorption and biodegradation. Simplistically, what comes in, must go out. That axiom holds true regardless of the degree of saturation; advection, diffusion, adsorption, and biodegradation are largely independent of the degree of saturation. AT123D is an analytical transport code capable of simulating contaminant transport in groundwater resulting from temporally varying source loading rates (SESOIL output). DAF calculations determine expected RGA temporal groundwater concentrations that result from mixing contaminated UCRS groundwater with “clean” underlying RGA groundwater. When DAF calculations are performed in reverse by assuming an allowable RGA groundwater concentration (MCL), the equation yields the maximum allowable soil contaminant concentrations that are protective of RGA groundwater quality.

The contents of the report are as follows:

- Section C.2 summarizes UCRS and RGA hydrostratigraphy, discusses how UCRS/RGA contact was determined, and lists the UCRS thickness at SWMU 1 and the C-720 Building northeast (NE) and southeast (SE) sources.
- Section C.3 presents SESOIL/AT123D model and DAF calculation inputs. The inputs include: site-specific vertical soil contaminant concentrations, soil layer discretization, and groundwater transport properties.
- Section C.3 presents SESOIL/AT123D modeling and DAF calculation results for both SWMU 1 and the C-720 Building sources.
- Section C.4 provides a discussion of prediction uncertainty including probabilistic modeling.
- Section C.5 summarizes pertinent conclusions.

## **C.2. CONTINENTAL RECHARGE SYSTEM AND REGIONAL GRAVEL AQUIFER HYDROSTRATIGRAPHY**

At Paducah Gaseous Diffusion Plant (PGDP), shallow hydrostratigraphy consists of the Continental Recharge System (CRS) and RGA. The CRS is divided into a less permeable UCRS and more permeable Lower Continental Recharge System (LCRS). As the name implies, the overlying UCRS provides recharge to the underlying more permeable LCRS and RGA. As conceptualized, groundwater moves primarily vertically through the UCRS until encountering the more permeable LCRS and RGA, at which point groundwater flow becomes primarily horizontal.

PGDP hydrogeologists have differentiated the UCRS into three general horizons (DOE 1999; DOE 2006):

- Hydrologic Unit 1 (HU1)—an upper silt and clay interval,
- Hydrologic Unit 2 (HU2)—an intervening sand and gravel interval, and
- Hydrologic Unit 3 (HU3)—a lower silt and clay interval.

Where the HU3 confining unit is clearly defined, it consists of yellowish brown and grayish brown silty clay with minor sand content. When present, the dominant lithology of the LCRS (HU4) is a fine-grading downward-to-medium-grained sand (DOE 2006). The RGA (HU5) consists of sands and gravels and is conceptualized as much more permeable than either the UCRS or LCRS. As stated previously, the HU3/HU4 contact is assumed to be the depth at which groundwater flow transitions from primarily vertical to primarily horizontal.

Tables C.2 and C.3 summarize the depths at which the HU3/HU4 contact was encountered in SWMU 1 and C-720 Building soil borings and monitoring wells (Attachments 1 and 2 of this Appendix). The HU3/HU4 contact was encountered at an average depth of 53.0 ft and 58.4 ft at SWMU 1 and the C-720 Building, respectively. Figures C.1 and C.2 are cross sections of lithology beneath SWMU 1 and the C-720 Building, respectively. The RGA and LCRS (HU4) are typically 30-ft and 5-ft thick, respectively, beneath the PGDP.

**Table C.2. HU3/HU4 Contact at SWMU 1**

<b>Borehole</b>	<b>Depth to H3/H4 contact (ft below ground surface)</b>
001-075	55
001-082	53
001-083	45
001-084	50
MW-161	50.6
<i>Additional Boreholes</i>	
001-076b	58
001-078	55
001-080	57
001-081	53
<i>Statistics</i>	
Minimum	45
Maximum	58
<b>Average</b>	<b>53.0</b>

**Table C.3. HU3/HU4 Contact at C-720**

<b>Borehole</b>	<b>Depth to H3/H4 contact (ft below ground surface)</b>
720-011	65
720-016	50
720-017	45
720-018	54
720-028	66
<i>Additional Boreholes</i>	
720-010	66
MW-203	63
<i>Statistics</i>	
Minimum	45
Maximum	66
<b>Average</b>	<b>58.4</b>

**THIS PAGE INTENTIONALLY LEFT BLANK**

**A**  
NORTHWEST  
ELEVATION  
(FT/AMSL)

**A'**  
SOUTHEAST  
ELEVATION  
(FT/AMSL)

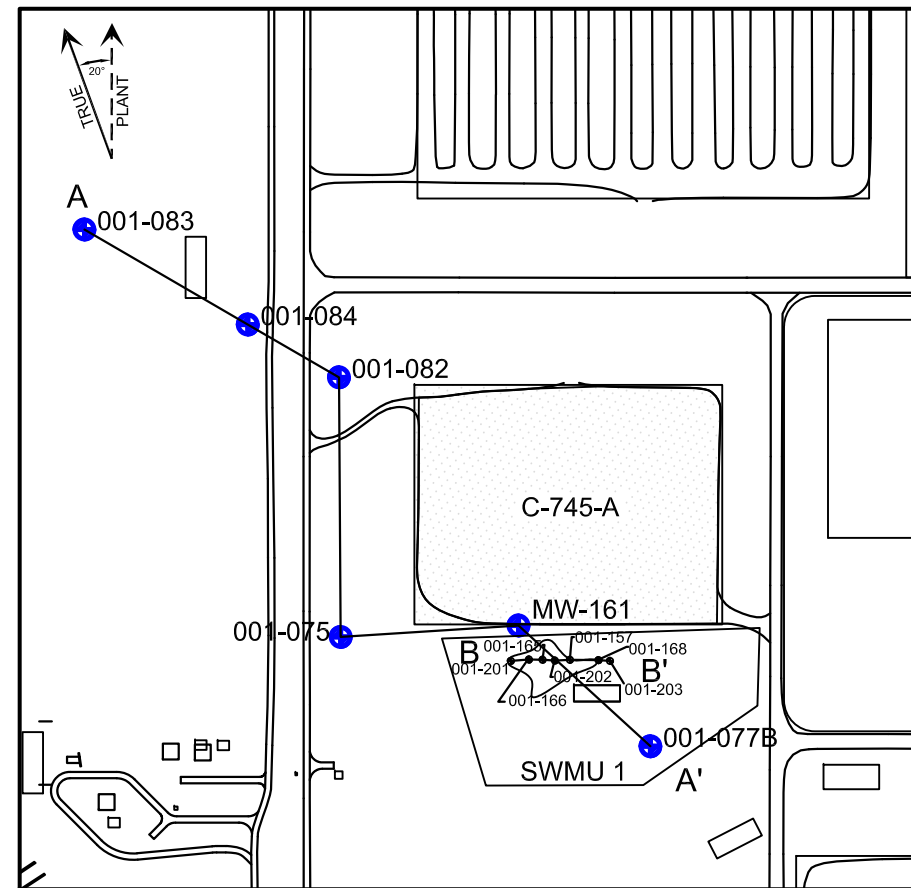
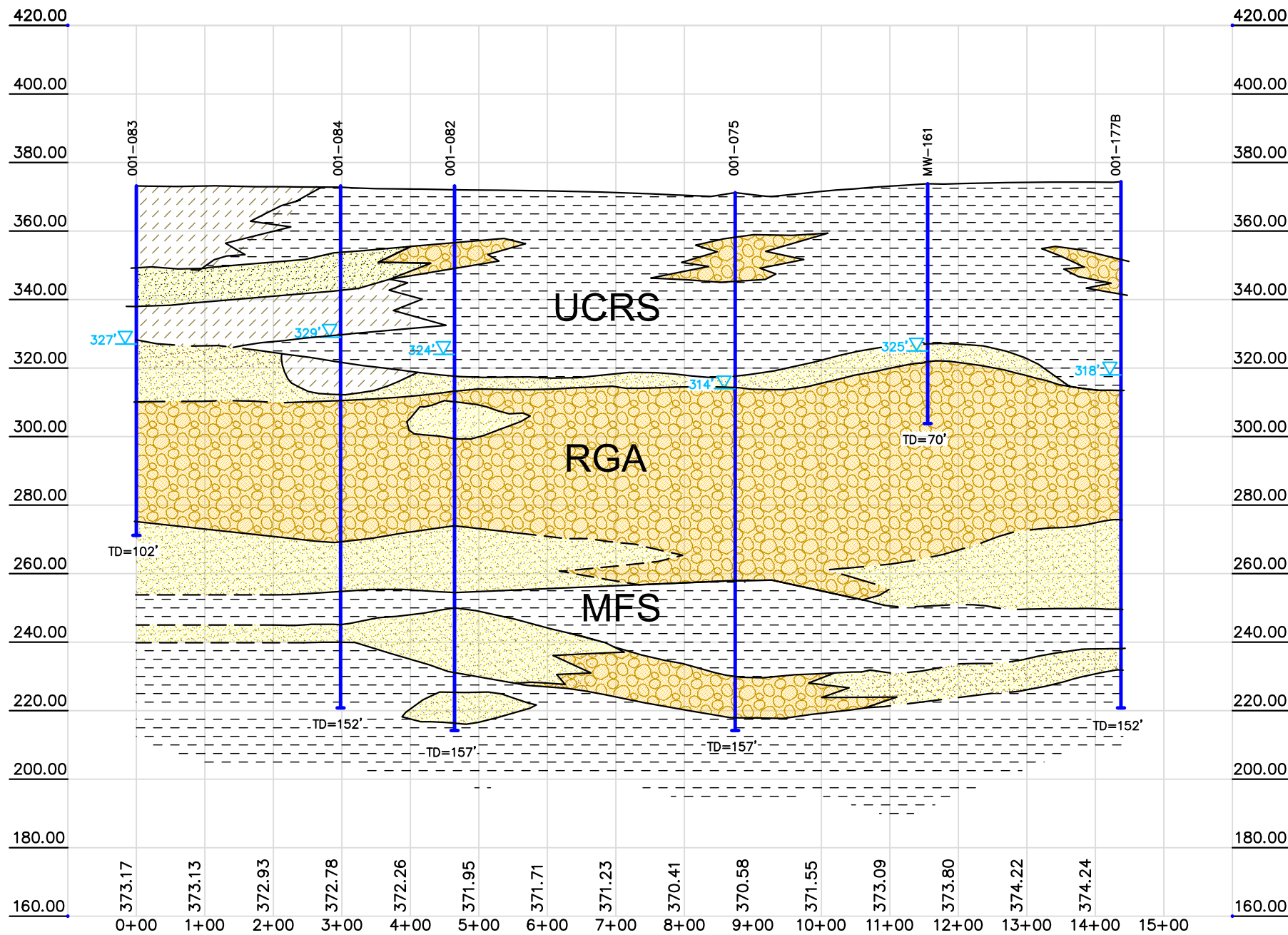

**LOCATION MAP**  
SCALE: 1" = 300'

**LEGEND**

- CLAY
- GRAVEL
- SAND
- SILT
- WATER LEVEL AT TIME OF GEOPHYSICAL LOG
- DASHED WHERE INFERRED
- UCRS - UPPER CONTINENTAL RECHARGE SYSTEM
- RGA - REGIONAL GRAVEL AQUIFER
- MFS - McNAIRY FLOW SYSTEM

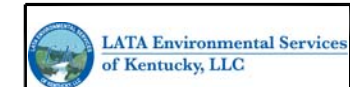
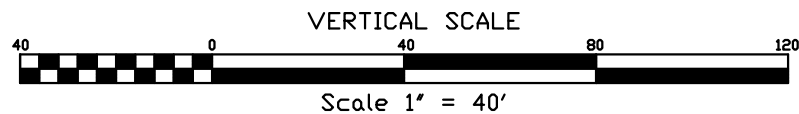
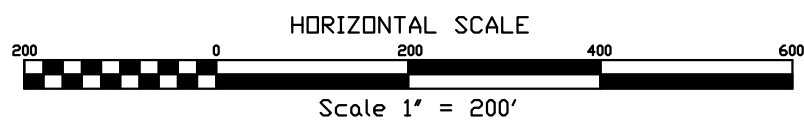

U.S. DEPARTMENT OF ENERGY  
DOE PORTSMOUTH/PADUCAH PROJECT OFFICE  
PADUCAH GASEOUS DIFFUSION PLANT

**Figure C.1.**  
**Geologic Cross Section A-A' at SWMU 1**

FILE NAME: Figure C.1 PROJECT # 11105 SCALE: AS NOTED DATE: 1/4/2011



**B**  
**NORTHWEST**

**B'**  
**NORTHEAST**

ELEVATION  
(FT/AMSL)

ELEVATION  
(FT/AMSL)

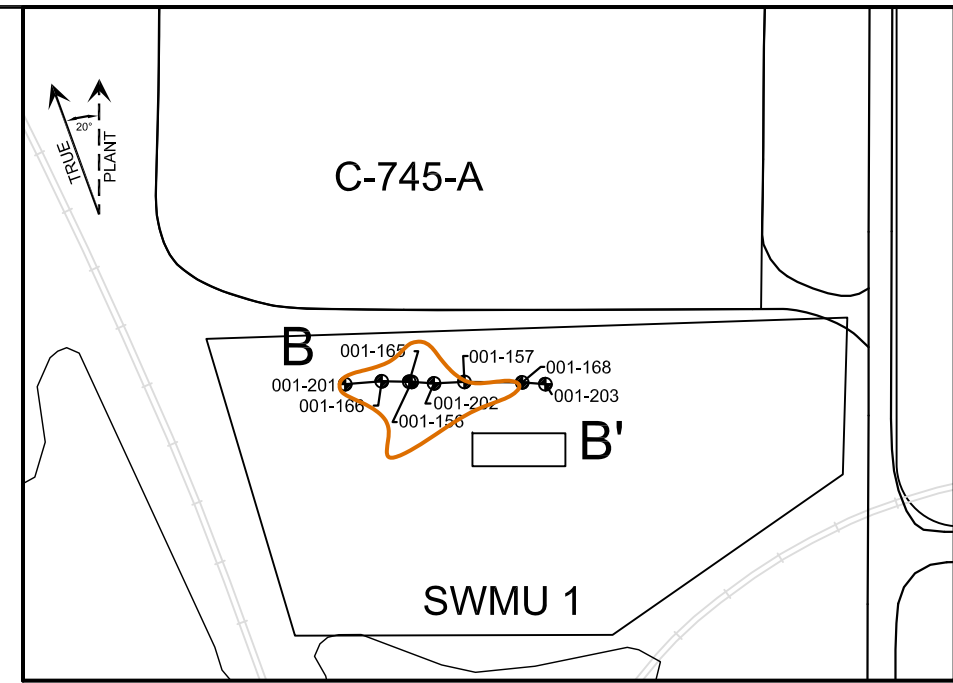
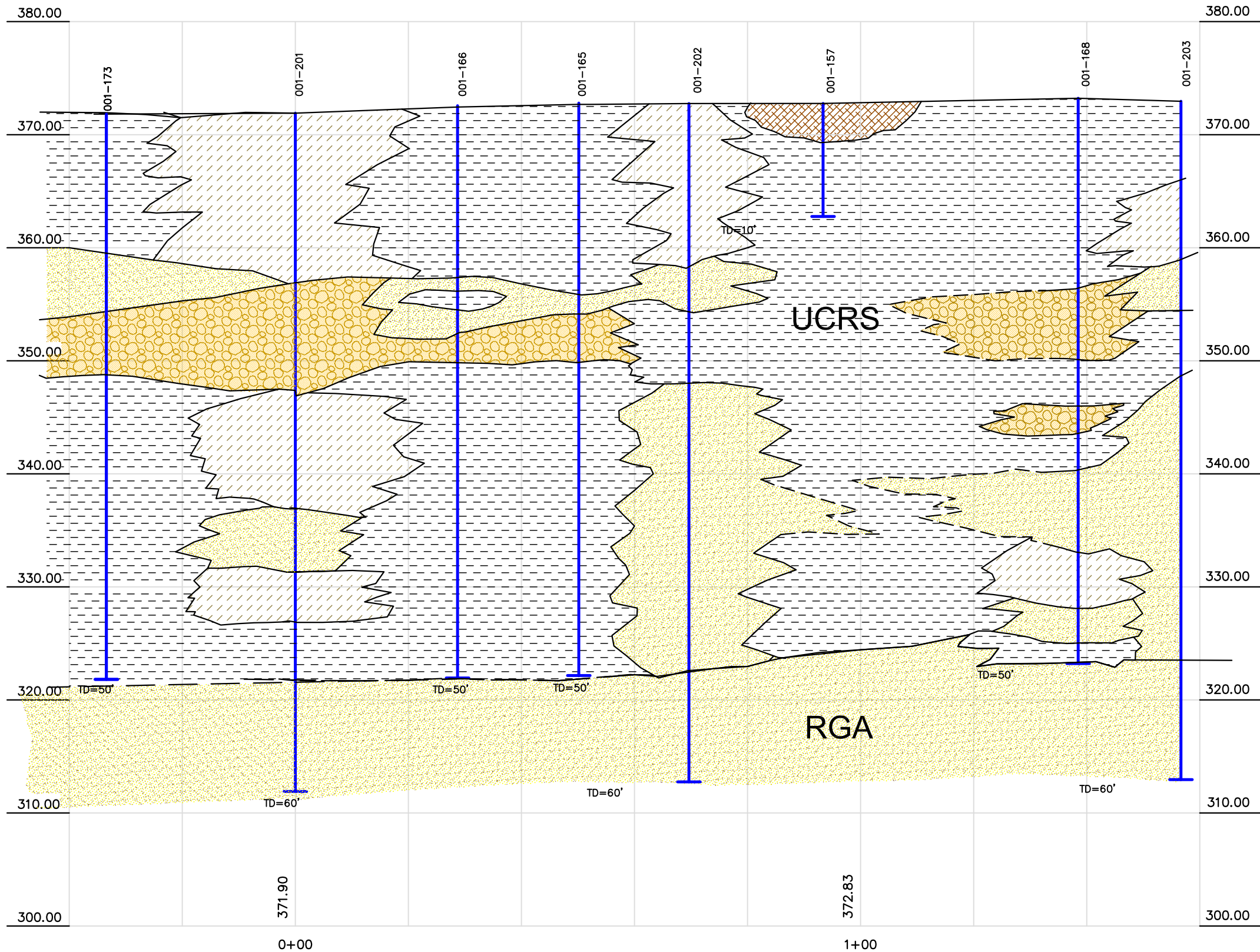

**LOCATION MAP**  
SCALE: 1" = 150'

**LEGEND**

- GRAVEL
- CLAY
- SAND
- SILT
- FILL
- DASHED WHERE INFERRED
- UCRS - UPPER CONTINENTAL RECHARGE SYSTEM
- RGA - REGIONAL GRAVEL AQUIFER

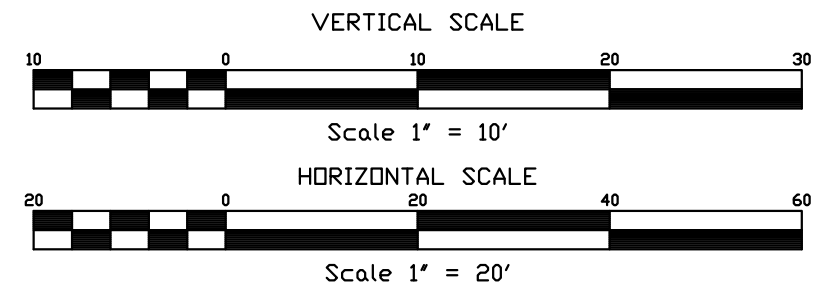

	U.S. DEPARTMENT OF ENERGY DOE PORTSMOUTH/PADUCAH PROJECT OFFICE PADUCAH GASEOUS DIFFUSION PLANT		
	<b>Figure C.2.</b> <b>Geologic Cross Section B-B' at SWMU 1</b>		
FILE NAME: Figure C.2	PROJECT #: 11105	SCALE: AS NOTED	DATE: 1/4/2011

### C.3 SESOIL AND AT123D MODELING AND DAF CALCULATIONS

SESOIL and AT123D modeling were coupled together to determine the effects of systematic reductions of SWMU 1 and C-720 Building soil contaminant concentrations on underlying RGA groundwater quality for UCRS biodegradation half-lives ranging from 5 to 50 years. Of primary interest is the time required for RGA groundwater contaminant concentrations to drop below MCLs. Table C.4 summarizes the site parameters used for SWMU 1 and the C-720 Building SESOIL modeling. The chemical-specific parameters used in the SESOIL modeling for each contaminant of concern (COC) included solubility in water, organic carbon partition coefficient ( $K_{oc}$ ), Henry's Law constant, distribution coefficient ( $K_d$ ), diffusion coefficients in air and water, and, for TCE, degradation rate constant are presented in Table C.5.  $K_d$  values for TCE; *cis*- and *trans*-1, 2-dichloroethene (DCE); VC, and 1,1-DCE were derived using the following relationship.

$$K_d = K_{oc} \times f_{oc}$$

where:  $K_d$  is the distribution coefficient,

$K_{oc}$  is the organic carbon partition coefficient, and

$f_{oc}$  is the fraction of organic carbon for source area soils.

**Table C.4. Soil Parameters Used in SESOIL Modeling of SWMU 1 and the C-720 Building Area<sup>a</sup>**

Input Parameter	SWMU 1	C-720 Building	Source
Soil type	Silty clay	Silty clay	PGDP site-specific
Bulk density (g/cm <sup>3</sup> )	1.46	1.46	Laboratory analysis
Percolation rate (cm/year)	11	11	PGDP calibrated model
Intrinsic permeability (cm <sup>2</sup> )	1.65E-10	1.65E-10	Calibrated
Disconnectedness index	10	10	Calibrated
Porosity	0.45	0.45	Laboratory analysis
Depth to water table (m)	16.76	18.29	Site specific (to RGA) based on field observation
Organic carbon content ( $f_{oc}$ ) (%)	0.08	0.09	Laboratory analysis
Frendlich equation exponent	1	1	SESOIL default value

<sup>a</sup> Parameter values from the Southwest Plume SI Report (DOE 2007).

PGDP = Paducah Gaseous Diffusion Plant

RGA = Regional Gravel Aquifer

**Table C.5. Chemical-Specific Parameters of the Contaminants of Concern Used in SESOIL Modeling<sup>a</sup>**

Contaminant of Concern	Mol. Wt. (MW) (g/gmol)	Solubility in water (mg/L)	Diffusion in air (cm <sup>2</sup> /s)	Diffusion in water (m <sup>2</sup> /hr)	Henry's Constant (atm.m <sup>3</sup> /mol)	$K_{oc}$ (L/kg)	$K_d^b$ (L/kg)		Degradation Half Life <sup>c</sup> (years)
							SWMU 1	C-720	
trichloroethene	131	1,100	0.08	3.28E-06	0.0103	94	0.0752	0.0846	5, 25, 50
<i>cis</i> -1,2-dichloroethene	97	3,500	0.07	4.07E-06	0.00408	36	0.0288	0.0324	infinite
<i>trans</i> -1,2-dichloroethene	97	6,300	0.07	4.28E-06	0.00938	38	0.0304	0.0342	infinite
vinyl chloride	63	2,760	0.11	4.43E-07	0.0270	19	0.0152	0.0171	infinite
1,1-dichloroethene	97	2,250	0.09	3.74E-06	0.0261	65	0.0520	0.0585	infinite

<sup>a</sup> Parameter values from the Southwest Plume SI Report (DOE 2007).

<sup>b</sup>  $K_d$  of an organic compound depends on the soil's organic carbon content ( $f_{oc}$ ) and compound's organic carbon partition coefficient ( $K_{oc}$ ).

<sup>c</sup> Half-life refers to the time it takes for a contaminant to lose half of its mass due to biodegradation.

The UCRS  $f_{oc}$  used for SWMU 1 and C-720 were 0.08% and 0.09%, respectively. The mechanisms and rates of TCE biodegradation within the UCRS have not yet been substantively assessed; consequently, a range of degradation rates (5, 25, and 50 years) was used in this assessment to determine the effects of degradation on overall remedy time frames. For conservatism, it was assumed that the remaining contaminants of concern (*cis*-DCE, *trans*-DCE, VC, and 1,1-DCE) did not undergo biodegradation.

For better source representation of vertical contaminant distributions and to improve the flux mass balance, the SWMU 1 and C-720 source zones were divided into 10 and 11 layers, respectively. Tables C.6 and C.7 summarize average contaminant concentrations and layer thickness for the two source areas.

**Table C.6. Summary of Source Term Characteristics for SWMU 1<sup>a</sup>**

Layer	Depth (ft)	Average (mg/kg)	Area (ft <sup>2</sup> )	Volume (ft <sup>3</sup> )	Mass <sup>b</sup> (g)
<b><i>Trichloroethene</i></b>					
Layer 1	00–10	7.59	4,375	43,750	13,723
Layer 2	10–20	110.8	3,125	31,250	143,177
Layer 3	20–30	17.6	6,250	62,500	45,503
Layer 4	30–40	13.0	5,625	56,250	30,283
Layer 5	40–50	13.6	5,625	56,250	31,516
Layer 6–9	50–54	5.74	7,500	30,000	7,119
Layer 10	54–55	5.74	7,500	7,500	1,780
Total Mass					273,068
<b><i>cis</i>-1,2-Dichloroethene</b>					
Layer 1	00–10	6.00	4,375	43,750	10,852
Layer 2	10–20	0.046	3,125	31,250	59
Layer 3	20–30	0.086	6,250	62,500	222
Layer 4	30–40	1.7	5,625	56,250	3,953
Layer 5	40–50	1.0	5,625	56,250	2,326
Layer 6–9	50–55	0.02	7,500	30,000	29
Layer 10	54–55	0.02	7,500	7,500	7
Total Mass					17,449
<b><i>trans</i>-1,2-Dichloroethene</b>					
Layer 1	00–10	16.0	4,375	43,750	28,940
Layer 2	10–20	1.5	3,125	31,250	1,938
Layer 3	20–30	1.5	6,250	62,500	3,876
Layer 4	30–40	0.6	5,625	56,250	1,395
Layer 5	40–50	1.4	5,625	56,250	3,256
Layer 6–9	50–55	0.00	7,500	30,000	0
Layer 10	54–55	0.00	7,500	7,500	0
Total Mass					39,405
<b><i>Vinyl chloride</i></b>					
Layer 1	00–10	0.7	4,375	43,750	1,266
Layer 2	10–20	0.0033	3,125	31,250	4
Layer 3	20–30	0.088	6,250	62,500	227
Layer 4	30–40	0.012	5,625	56,250	28
Layer 5	40–50	0.0095	5,625	56,250	22
Layer 6–9	50–55	0.02	7,500	30,000	22
Layer 10	54–55	0.02	7,500	7,500	6
Total Mass					1,576

**Table C.6. Summary of Source Term Characteristics for SWMU 1<sup>a</sup> (Continued)**

Layer	Depth (ft)	Average (mg/kg)	Area (ft <sup>2</sup> )	Volume (ft <sup>3</sup> )	Mass <sup>b</sup> (g)
<i>1,1-Dichloroethene</i>					
Layer 1	00–10	0.01	500	5,000	2
Layer 2	10–20	0.00	0	0	0
Layer 3	20–30	0.04	1,000	10,000	17
Layer 4	30–40	0.04	1,600	16,000	26
Layer 5	40–50	0.03	2,800	28,000	29
Layer 6–9	50–55	0.06	850	3,400	8
Layer 10	54–55	0.06	850	850	2
Total Mass					84

<sup>a</sup> Layer concentrations from the Southwest Plume SI Report (DOE 2007).

<sup>b</sup> Mass calculated using an average bulk density of 1.46 g/cm<sup>3</sup>.

**Table C.7. Summary of Source Term Characteristics for the C-720 Building Area Source<sup>a</sup>**

Layer	Depth (ft)	Average (mg/kg)	Area (ft <sup>2</sup> )	Volume (ft <sup>3</sup> )	Mass <sup>b</sup> (g)
<i>Trichloroethene</i>					
Layer 1	00–10	2.96	7,500	75,000	9,185
Layer 2	10–20	6.37	7,500	75,000	19,751
Layer 3	20–30	11.9	15,000	150,000	73,900
Layer 4	30–40	1.55	6,875	68,750	4,393
Layer 5	40–50	1.20	6,875	68,750	3,411
Layer 6–10	50–55	0.10	6,875	34,375	142
Layer 11	55–60	0.00	6,875	34,375	0
Total Mass					110,684
<i>cis-1,2-Dichloroethene</i>					
Layer 1	00–10	3.2	7,500	75,000	9,922
Layer 2	10–20	0.75	7,500	75,000	2,326
Layer 3	20–30	0.019	15,000	150,000	118
Layer 4	30–40	0.052	6,875	68,750	148
Layer 5	40–50	0	6,875	68,750	0
Layer 6–10	50–55	0.00	6,875	34,375	0
Layer 11	55–60	0.00	6,875	34,375	0
Total Mass					12,513
<i>trans-1,2-Dichloroethene</i>					
Layer 1	00–10	0	7,500	75,000	0
Layer 2	10–20	0.4	7,500	75,000	1,240
Layer 3	20–30	0	15,000	150,000	0
Layer 4	30–40	0	6,875	68,750	0
Layer 5	40–50	0	6,875	68,750	0
Layer 6–10	50–55	0.00	6,875	34,375	0
Layer 11	55–60	0.00	6,875	34,375	0
Total Mass					1,240

**Table C.7. Summary of Source Term Characteristics for the C-720 Building Area Source<sup>a</sup> (Continued)**

Layer	Depth (ft)	Average (mg/kg)	Area (ft <sup>2</sup> )	Volume (ft <sup>3</sup> )	Mass <sup>b</sup> (g)	
<i>Vinyl chloride</i>						
	Layer 1	00–10	0.4	7,500	75,000	1,240
	Layer 2	10–20	0.4	7,500	75,000	1,240
	Layer 3	20–30	0	15,000	150,000	0
	Layer 4	30–40	0	6,875	68,750	0
	Layer 5	40–50	0	6,875	68,750	0
	Layer 6–10	50–55	0.00	6,875	34,375	0
	Layer 11	55–60	0.00	6,875	34,375	0
	Total Mass					2,481
<i>1,1-Dichloroethene</i>						
	Layer 1	00–10	0.0	0	0	0
	Layer 2	10–20	0.0	0	0	0
	Layer 3	20–30	0.0	0	0	0
	Layer 4	30–40	0.18	5,600	56,000	417
	Layer 5	40–50	0.0305	15,000	150,000	189
	Layer 6–10	50–55	0.0020	2,150	10,750	1
	Layer 11	55–60	0.0020	2,150	10,750	1
	Total Mass					611

<sup>a</sup> Layer concentrations from the Southwest Plume SI Report (DOE 2007).

<sup>b</sup> Mass calculated using an average bulk density of 1.46 g/cm<sup>3</sup>.

Using the listed parameters as input, SESOIL calculated temporal groundwater contaminant concentrations in the UCRS at the HU3/HU4 contact, which were used as input for AT123D. Additional AT123D input parameters are summarized in Table C.8.

**Table C.8. Hydrogeologic Parameters Used in AT123D Modeling<sup>a</sup>**

Input Parameter	C-720		Source
	SWMU 1	Building	
Bulk density (kg/m <sup>3</sup> )	1,670	1,670	Laboratory analysis
Effective porosity	0.3	0.3	PGDP sitewide model calibrated value
Hydraulic conductivity (m/hour)	16.2	16.2	Average value from Tables C.7 and C.8
Hydraulic gradient	0.0004	0.0004	PGDP sitewide model calibrated value
Aquifer thickness	9.14 m	9.14 m	Site average
	30 ft	30 ft	
Longitudinal dispersivity (m)	1.5	1.5	
Density of water (kg/m <sup>3</sup> )	1,000	1,000	Default
Fraction of organic carbon (%)	0.02	0.02	Laboratory analysis
Well screen length (m)	3	3	Assumed a 10 ft well screen mixing zone

<sup>a</sup> Parameter values from the Southwest Plume SI Report (DOE 2007).

DAF calculations were performed to determine the maximum allowable UCRS soil concentrations that are protective of RGA groundwater quality. The DAF was calculated using the following equation:

$$DAF = 1 + \frac{Kid}{IL}$$

Where:

- i = gradient (m/m)
- d = mixing zone depth (m)
- I = infiltration rate (m/yr)
- L = length of area of concern parallel to groundwater flow (m)
- K = aquifer hydraulic conductivity (m/yr)

The equation for calculating the aquifer mixing zone depth, d:

$$d = (0.0112 L^2)^{0.5} + d_a \left\{ 1 - e^{\left[ \frac{(-LI)}{(K i d_a)} \right]} \right\}$$

Where:

- $d_a$  = aquifer thickness (m)

The first term,  $d_{av}$ , estimates the depth of the mixing due to vertical dispersivity along the length of the groundwater flow path:

$$d_{av} = (0.0112 L^2)^{0.5}$$

The second term,  $d_{iv}$ , estimates the depth of mixing due to the downward velocity of infiltrating water:

$$d_{iv} = d_a \left\{ 1 - e^{\left[ \frac{(-LI)}{(K i d_a)} \right]} \right\}$$

Input parameters for the DAF calculations are summarized in Table C.9 and Table C.10 from the Site Investigation (SI) Report (DOE 2007) for SWMU 1 and C-720, respectively. The effective aquifer hydraulic conductivity for the RGA/HU4 stratigraphic sequence (0.45 cm/s, 1.42E+05 m/yr) was calculated as the arithmetic average of the RGA hydraulic conductivity (0.53 cm/s, 9.14 m thickness) and HU4 hydraulic conductivity (0.001 cm/s, 1.5 m thickness). The DAF, the amount by which UCRS groundwater contamination can expect to be diluted beneath the source areas, was calculated to be 59 for both SWMU 1 and C-720.

**Table C.9. SWMU 1 Parameter Values for Calculation of the DAF**

Parameter	Value	Description
L	17.04	L corresponds to the square root of the source area (Table F.28, DOE 2007) and is the length of the source area parallel to groundwater flow.
d <sub>a</sub>	9.14	Aquifer thickness (m) Table F.34 SI Report
I	0.1054	Infiltration rate (m/yr) 10.54 cm/yr SESOIL net recharge rate to groundwater
K	1.42E+05	Aquifer hydraulic conductivity (m/yr) average of silty sand (5 ft) at 10 <sup>-3</sup> cm/s and gravel (30 ft) at 0.529 cm/s from SI Table F.34
i	4.00E-04	Hydraulic gradient (m/m) Table F.34 SI Report

**Table C.10. C-720 Parameter Values for Calculation of the DAF**

Parameter	Value	Description
L	37.3	L corresponds to the square root of the source area (Table F.28, DOE 2007) and is the length of the source area parallel to the groundwater flow.
d <sub>a</sub>	9.14	Aquifer thickness (m) Table F.34 of SI Report (DOE 2007)
I	0.1054	Infiltration rate (m/yr) 10.54 cm/yr SESOIL net recharge rate to groundwater
K	1.42E+05	Aquifer hydraulic conductivity (m/yr) Average of silty sand (5 ft) at 10 <sup>-3</sup> cm/s and gravel (30 ft) at 0.529 cm/s from SI Report Table F.34 (DOE 2007)
i	4.00E-04	Hydraulic gradient (m/m) Table F.34 SI Report (DOE 2007)

### SWMU 1 Results

Remedial technologies under consideration at SWMU 1 are the following:

- Deep Soil Mixing with Enhancements,
- Large Diameter Auger Excavation with Deep *In situ* Treatment,
- *In situ* Thermal Treatment,
- Long-term Monitoring, and
- Enhanced *In situ* Bioremediation.

For modeling purposes, we assumed that the treatment technologies do not materially alter UCRS hydrologic properties (except for excavation). Thus, the soil properties within SESOIL were not altered in the evaluation simulations. Soil excavation will change UCRS soil properties because a column of soil will be removed to within approximately 10 ft of the HU3/HU4 contact, and the excavated soil will be replaced by sand, a more permeable material. It needs to be acknowledged that changing the hydraulic conductivity profile within SESOIL to reflect the higher hydraulic of the emplaced sand relative to the native UCRS resulted in an error message that the configuration produced near zero soil moisture and the simulation could not be completed. To overcome this limitation, it was assumed that the hydraulic

conductivity of the emplaced media was the same as the original UCRS. In addition, the excavation scenario assumed that contamination in the excavated portion of soil column is zero rather than a percentage decline from the original contaminant concentration levels. Native soil contamination concentrations below the excavated material were simulated at original concentrations and as incremental declining percentages from the original contaminant concentration levels.

Table C.11 combines the TCE average concentration profile presented by layer in Table C.6 with the expected removal percentage presented in Table C.1 to yield expected posttreatment concentrations by layer.

**Table C.11. Expected Posttreatment Average TCE Concentrations by Layer for SWMU 1**

Layer/Depth(ft)	Average TCE Conc. (mg/kg)	Post-DSM TCE Conc. (mg/kg)	Post-LDA TCE Conc. (mg/kg)	Post-ERH TCE Conc. (mg/kg)	Post-EISB TCE Conc. (mg/kg)
	<i>Percentage Removal</i>	<b>91%</b>	<b>100%/0%</b>	<b>98%</b>	<b>60%</b>
Layer 1/00-10	7.59	0.68	0	0.15	3.04
Layer 2/10-20	110.8	9.97	0	2.22	44.3
Layer 3/20-30	17.6	1.58	0	3.52	7.04
Layer 4/30-40	13.0	1.17	0	2.60	5.20
Layer 5/40-50	13.6	1.17	6.8	2.72	5.44
Layer 6-9/50-54	5.74	0.52	5.74	0.11	2.30
Layer 10/54-55	5.74	0.52	5.74	0.11	2.30
Total Mass (lbs)	601	54	20	12	240

Conc. = concentration  
 DSM = deep soil mixing  
 EISB = enhanced *in situ* bioremediation  
 ERH = electrical resistance heating  
 LDA = large diameter auger

Figure C.3 summarizes AT123D modeling results as percent soil contaminant reduction versus years to reach the TCE MCL for RGA groundwater at the SWMU boundary for a range of biological half-lives. The figure can be used to assess the expected performance of the various proposed remedial technologies (Table C.12). Evaluation shows that, with the exception of thermal treatment with five-year TCE biological half-life, many decades will pass after UCRS soil remediation before RGA water quality will drop below the TCE MCL of 5 µg/L.

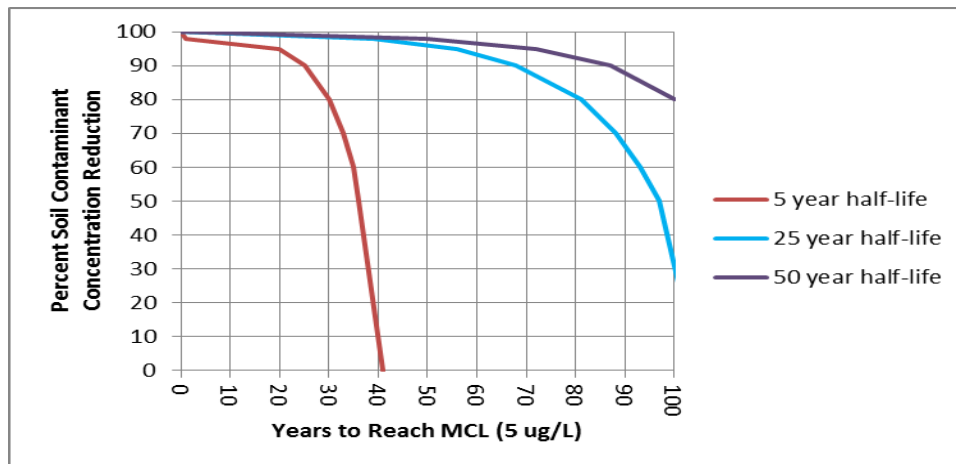

**Figure C.3. Time Required for Residual TCE Mass from SWMU 1 to Reach MCL (5 µg/L) in RGA**



**Table C.12. Expected Time Frames to Reach TCE MCL in the RGA at SWMU 1**

Remedial Alternative	Expected Reduction in Soil Contaminant Concentrations, %	Years to reach MCL in RGA Groundwater, 5-Year Half-Life	Years to reach MCL in RGA Groundwater, 25-Year Half-Life	Years to reach MCL in RGA Groundwater, 50-Year Half-Life
Deep Soil Mixing with Enhancements	91	25	68	87
Large Diameter Auger Excavation with Deep <i>In situ</i> Treatment	100 in excavated column, 0 in native soils	15	38	50
<i>In situ</i> Thermal Treatment	98	1	39	50
Enhanced <i>In situ</i> Bioremediation	60	35	93	> 100
Long-term Monitoring	0	41	> 100	> 100

Figure C.4 shows AT123D simulation results for Large Diameter Auger Excavation with Deep *In situ* Treatment. The results listed in Table C.12 are based on SESOIL runs having varying biodegradation rates (5-, 25-, and 50-year half-lives) where contamination was removed (assumed zero) to a depth of approximately 10 ft above the HU3/HU4 contact. Removing contaminated soil and replacing it with clean sand significantly reduces the time to achieve the TCE MCL in RGA groundwater. For a 25-year biological half-life and no remediation, time to reach TCE MCL in the RGA is reduced from > 100 years (long-term monitoring) to 38 years. If the remaining TCE soil contaminant concentrations beneath the sand column are reduced via *in situ* treatment, the time to reach the TCE MCL is reduced further.

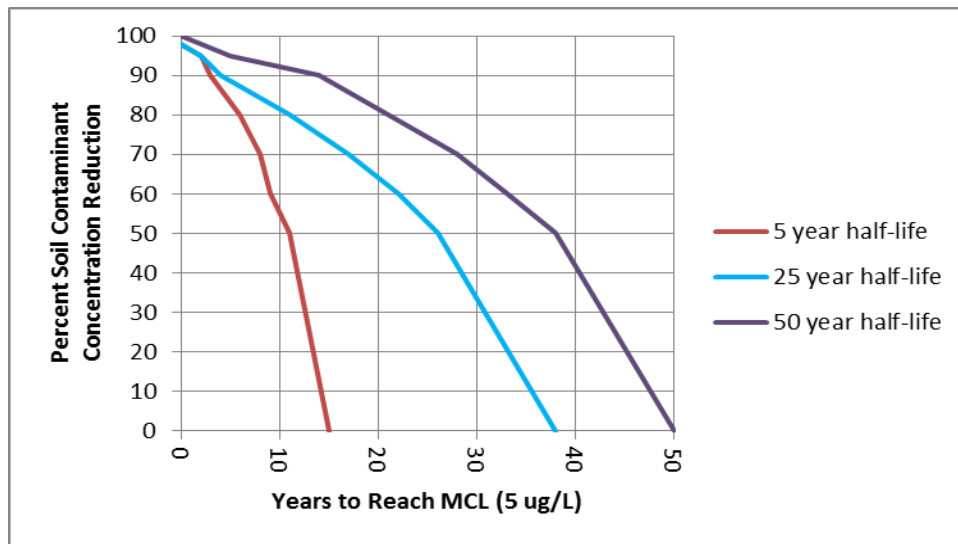

**Figure C.4. Time Required for Residual TCE Mass from SWMU 1 to Reach MCL (5 µg/L) in RGA for Large Diameter Auger Excavation**

The same procedure described above was used to evaluate SWMU 1 soil contaminants other than TCE. 1,1-DCE and VC were not included in the graph because UCRS soil concentrations are so low that concentrations reduce to MCLs in RGA groundwater without remediation (as a function of dilution). Different from the TCE simulations, however, was the assumption that biodegradation does not occur. In essence, the results are worst case and time to reach MCLs in RGA groundwater likely will be shorter

than the predicted times. Figure C.5 shows that minimal reduction in soil contaminant concentrations is required to rapidly drop expected RGA contaminant concentrations below MCLs. This is because the initial contaminant soil concentrations are less than the initial TCE soil contaminant concentrations and, with the exception of VC, the MCLs for the contaminants are higher than the TCE MCL.

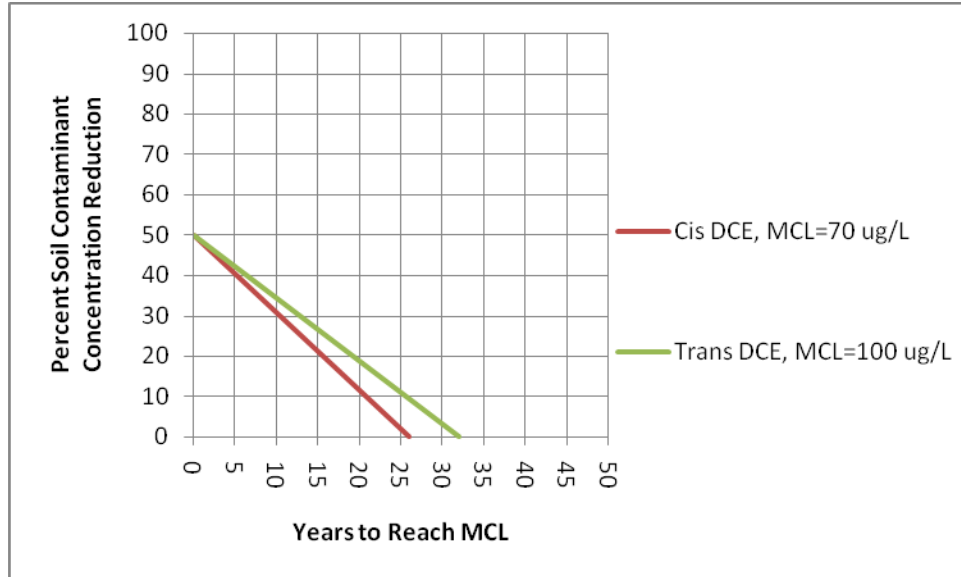

**Figure C.5. Time Required for Residual *cis*-DCE and *trans*-DCE Mass from SWMU 1 to Reach MCLs in RGA**

Required UCRS soil contamination concentrations to be protective of RGA groundwater quality were calculated using the following equation:

$$RG = \frac{(MCL) \times (C_s)}{C_{gw}}$$

Where:

- RG = soil remediation goal (mg/kg)
- MCL = MCL for the COC (µg/L)
- C<sub>s</sub> = soil concentration (mg/kg)
- C<sub>gw</sub> = groundwater concentration based on a unit soil concentration (µg/L)

If unit soil contaminant concentrations are used in SESOIL, then the equation simplifies to:

$$RG = \frac{(MCL)}{C_{gw}}$$

Table C.13 presents the allowable UCRS groundwater contaminant concentrations and bulk average soil contaminant remediation goals (RGs) for SWMU 1 to be protective of RGA groundwater quality.

**Table C.13. SWMU 1 Soil Remediation Goals for Groundwater Based on a DAF**

COC	Leachate Concentration at HU3/HU4 (µg/L)	Groundwater Concentration (µg/L) <sup>a</sup>	MCL (µg/L)	Soil RG for units above HU4 (mg/kg)
TCE (5-yr UCRS half-life)	295	5	5	0.085
TCE (25-yr UCRS half-life)	295	5	5	0.080
TCE (50-yr UCRS half-life)	295	5	5	0.073
1,1-DCE	413	7	7	0.130
<i>cis</i> -1,2-DCE	4,130	70	70	0.600
<i>trans</i> -1,2-DCE	5,900	100	100	1.080
Vinyl chloride	118	2	2	0.034

<sup>a</sup> DAF = 59

**C-720 Building Results**

Remedial technologies under consideration at C-720 NE and SE sources are as follows:

- *In situ* Thermal Treatment
- *In situ* Jet Chemical Source Treatment
- *In situ* Soil Flushing with Dual-Phase Extraction
- Long-term Monitoring

In general, the treatment technologies considered at C-720 minimally, if at all, alter UCRS hydrologic properties. Thus, the soil properties within SESOIL were not altered in the evaluation simulations.

Table C.14 combines the TCE average concentration profile presented by layer in Table C.7 with the expected removal percentage presented in Table C.1 to yield expected posttreatment concentrations by layer.

**Table C.14. Expected Posttreatment Average TCE Concentrations by Layer for C-720**

Layer/Depth(ft)	Average TCE Conc. (mg/kg)	Post-LAI TCE Conc. (mg/kg)	Post-MPE TCE Conc. (mg/kg)	Post-ERH TCE Conc. (mg/kg)
<b>Percentage Removal</b>		<b>90%</b>	<b>95%</b>	<b>98%</b>
Layer 1/00-10	2.96	0.30	0.15	0.15
Layer 2/10-20	6.37	0.64	0.32	2.22
Layer 3/20-30	11.9	1.19	0.6	3.52
Layer 4/30-40	1.55	0.16	0.08	2.60
Layer 5/40-50	1.20	0.12	0.06	2.72
Layer 6-10/50-55	0.10	0.01	0.005	0.11
Layer 11/55-60	0.00	0.00	0.00	0.00
Total Mass (lbs)	243	24	12	2

Conc. = concentration  
 ERH = electrical resistance heating  
 LAI = liquid atomized injection  
 MPE = multiphase extraction (with soil flushing)  
 TCE = trichloroethene

Figure C.6 summarizes the C-720 SE source AT123D modeling results as percent soil contaminant reduction versus years to reach the TCE MCL for RGA groundwater at the SWMU boundary for a range

of biological half-lives. As with SWMU 1, the figure can be used to assess the expected performance of the various proposed remedial technologies at C-720 (Table C.15). Simulation results suggest that application of *In situ* Thermal Treatment and *In situ* Soil Flushing with Multiphase Extraction will rapidly reduce RGA TCE concentrations to below the MCL for a TCE 5-year biological half-life. For the remaining technologies at a TCE 5-year half-life and all technologies for 25- and 50-year half-lives, decades will be required after application for RGA TCE concentrations to drop below the MCL.

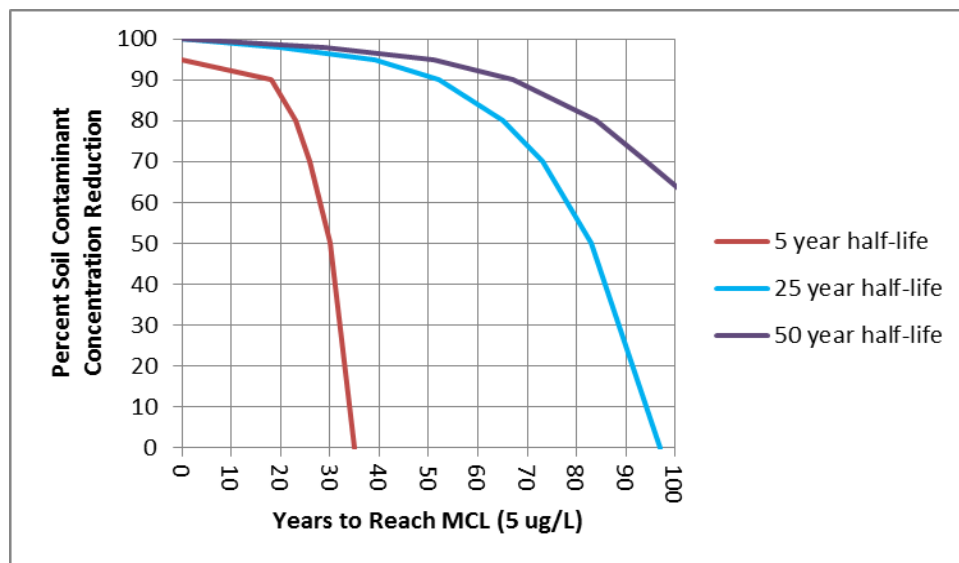

Figure C.6. Time Required for Residual TCE Mass from C-720 to Reach MCL (5 µg/L) in RGA

Table C.15. Expected Time Frames to Reach TCE MCL in the RGA at C-720

Remedial Alternatives	Expected Reduction in TCE Soil Concentrations, %	Years to reach MCL in RGA Groundwater, 5-Year Half-Life	Years to reach MCL in RGA Groundwater, 25-Year Half-Life	Years to reach MCL in RGA Groundwater, 50-Year Half-Life
<i>In situ</i> ERH Treatment	98	0	20	29
<i>In situ</i> LAI Source Treatment	90	18	52	67
<i>In situ</i> Soil Flushing with MPE	95	0	39	51
Long-term Monitoring	0	35	97	>100

ERH = electrical resistance heating  
LAI = liquid atomized injection  
MPE = multiphase extraction

AT123D simulation results for C-720 soil contaminants other than TCE show that minimal reductions in *cis*-DCE and VC soil contaminant concentrations are required to rapidly drop expected RGA contaminant concentrations below MCLs (Figure C.7). Results for *trans*-DCE and 1,1-dichloroethene are not shown because the initial prerediation concentrations are sufficiently low so that the contaminants do not negatively impact RGA water quality.

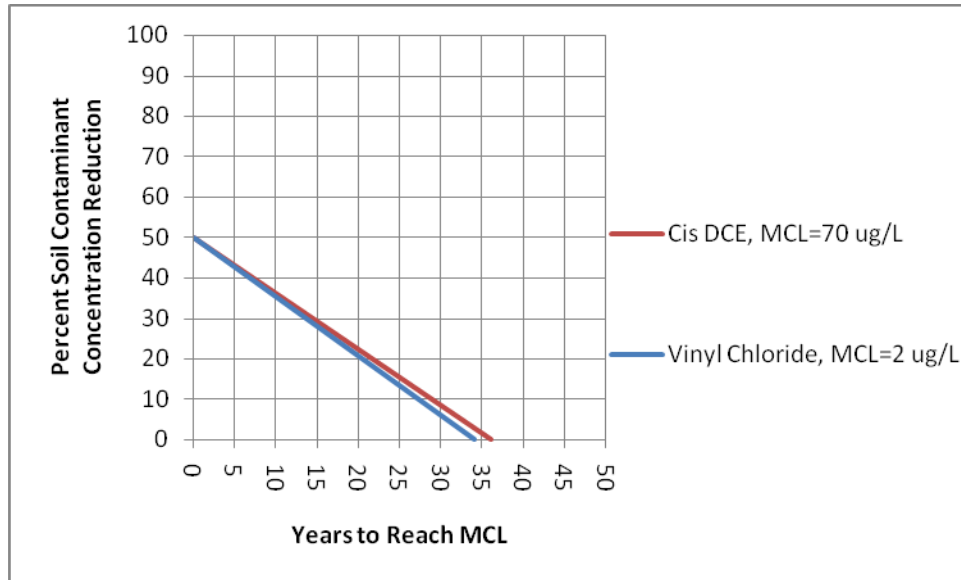

**Figure C.7. Time Required for Residual *cis*-DCE, *trans*-DCE, and VC Mass from C-720 to Reach MCLs in RGA**

As with SWMU 1, required UCRS soil contamination concentrations to be protective of RGA groundwater quality were calculated (DAF) for all of the C-720 soil contaminants (Table C.16).

**Table C.16. C-720 Soil Remediation Goals for Groundwater Based on a DAF**

COC	Leachate Concentration at HU3/HU4 (µg/L)	Groundwater Concentration (µg/L) <sup>a</sup>	MCL (µg/L)	Soil RG for units above HU4 (mg/kg)
TCE (5-yr UCRS half-life)	295	5	5	0.092
TCE (25-yr UCRS half-life)	295	5	5	0.083
TCE (50-yr UCRS half-life)	295	5	5	0.075
1,1-DCE	413	7	7	0.137
<i>cis</i> -1,2-DCE	4,130	70	70	0.619
<i>trans</i> -1,2-DCE	5,900	100	100	5.29
Vinyl chloride	118	2	2	0.450

<sup>a</sup> DAF = 59

## C.4 UNCERTAINTY ANALYSIS

Environmental characterization and predictions are inherently uncertain because interpretations are based on limited spatial and temporal data. For example, source characterization is based on a limited number of soil borings. It is likely that if the soil borings were located differently or more soil borings were installed, the source characterization would be different. The following sections discuss the uncertainty associated with various model input parameters and how that uncertainty potentially could influence the conclusions of this remedial evaluation. In addition, probabilistic modeling was performed to quantify how parameter uncertainty potentially influences model predictions with respect to RGs.

## **C.4.1 SITE CONCEPTUAL MODEL UNCERTAINTY**

The following sections discuss site conceptual model uncertainty.

### **C.4.1.1 Recharge**

The average recharge rate of 11 cm per year used in the remedial evaluations was determined via groundwater modeling and is the rate that best fits the calibrated PGDP hydraulic conductivity field. Recharge and hydraulic conductivity are positively correlated such that increases or decreases in one necessitates a similar change in the other. In addition, recharge is spatially and temporally variable across the site and could be different locally than the average recharge rate. Also, anthropogenic sources of recharge are possible at the SWMU 1 and C-720 sites. The amount of recharge from these sources may exceed that of natural recharge substantially. In summary, the actual recharge rate could be different than the modeled recharge rate.

Ramifications of the actual recharge rate being higher than the modeled recharge rate are faster UCRS advective transport (flushing) rates that would result in lower UCRS soil RG values assuming the same dissolved UCRS groundwater contaminant concentrations. A lower than expected recharge rates would reduce UCRS advective transport rates, which would result in higher UCRS soil RG values, assuming the same dissolved UCRS groundwater contaminant concentrations. Simplistically, the greater the volume of contaminated UCRS groundwater flow to the RGA, the smaller the dilution factor. Correspondingly, the smaller the volume of contaminated UCRS groundwater flow to the RGA, the higher the dilution factor. Given that anthropogenic recharge is hypothesized as being present at both SWMU 1 and C-720, it is possible that calculated soil RGs based on the average recharge rates are conservative.

### **C.4.1.2 Intrinsic Permeability and Porosity**

UCRS intrinsic permeability used in the SESOIL modeling is based on measured values of vertical hydraulic conductivity. Similarly, the UCRS porosity value (0.45) is based on laboratory analysis in the Waste Area Grouping 27 Remedial Investigation (DOE 1999). Both hydraulic conductivity and porosity measurements represent point measurements. Collection of hydraulic conductivity and porosity measurements at different locations likely would have resulted in different “typical” values.

If hydraulic conductivity is greater than characterized, assuming a consistent hydraulic gradient, UCRS groundwater flow rates will be higher, which will result in less dilution in the RGA, which corresponds to lower allowable UCRS soil RGs. If UCRS hydraulic conductivity is less than characterized, again assuming a consistent hydraulic gradient, UCRS groundwater flow rates will be lower, which will result in less dilution in the RGA, which corresponds to higher allowable UCRS soil RGs. Without site-specific hydraulic conductivity information, it is impossible to assess the representativeness of the calculated UCRS soil RGs.

Variable porosity has no effect on predicted soil RGs assuming a constant recharge rate. This is because porosity doesn't control the volume of groundwater flowing through the UCRS only the rate at which it moves. The situation is analogous to different diameter garden hoses coupled together. Flow velocities will be slower in the larger diameter hose relative to the smaller diameter hose, but continuity dictates that the same volume of water passes through both hoses over a given time period. Thus, UCRS groundwater volumetric flow rate is expected to remain constant, assuming a constant recharge rate, regardless of the magnitude of porosity. A constant UCRS volumetric contaminated groundwater flow rate results in a constant UCRS soil RG.

### **C.4.1.3 Saturation**

Assuming homogeneous recharge, the degree of saturation in the UCRS is a function of soil types, and soil types are expected to vary both horizontally and vertically at SWMU 1 and C-720 sites. Unsaturated hydraulic conductivity is a function of the degree of saturation. However, even with variability in the degree of saturation, the volume of contaminated groundwater passing through the UCRS and entering the RGA will be equal to the volumetric recharge rate entering the top of the UCRS. Simplistically, what comes in must come out. Thus, variability in the degree of UCRS saturation will not alter the estimated UCRS soil RG.

### **C.4.2. TCE RG PROBABILISTIC MODELING**

An uncertainty analysis was conducted using probabilistic analyses to evaluate the soil remediation goals for TCE. The probabilistic analyses were based on the parameter distributions presented in the Southwest Plume SI (DOE 2007). The modeling was conducted using unit soil concentrations (i.e., 1 mg/kg) in each layer that exhibited contamination shown in Tables C.3 and C.4 to facilitate the back calculation of the soil RGs using DAF methodologies.

The parameter values used in the analysis are provided in Table C.17 for SWMU 1 SESOIL model, Table C.18 for the C-720 SESOIL model, with the exception that the TCE degradation rate in the UCRS was infinite (i.e., 0 yr half-life).

Each of the 100 sets of input parameters for SWMU 1 and C-720 was used to generate TCE concentrations at the HU3/HU4 contact. The groundwater concentrations then were based on a DAF of 59, as discussed in Section C.3, as part of determination of the soil RGs.

### **C.4.3 SWMU 1 TCE RESULTS**

Figure C.8 provides a histogram of the remediation goals based on the maximum predicted groundwater concentrations for each of the 100 sets of input parameters. Table C.19 provides the soil remediation goals based on the 75% quartile, mean, median, geometric mean, and 25% quartile based on the maximum predicted groundwater concentrations for each of the 100 sets of input parameters.

Table C.17. SWMU 1 SESOIL Input Parameters Used in Probabilistic Modeling

Run (#)	Layer 1 Conc (mg/kg)	Layer 2 Conc (mg/kg)	Layer 3 Conc (mg/kg)	Layer 4 Conc (mg/kg)	Layer 5 Conc (mg/kg)	Layer 6 Conc (mg/kg)	Organic Carbon (%)	Degradation Rate (/hr)	Vertical Hydraulic Conductivity (m/hr)	Intrinsic Permeability (cm <sup>2</sup> )
001	1.00	1.00	1.00	1.00	1.00	1.00	0.08	infinite	8.61E-04	2.44E-10
002	1.00	1.00	1.00	1.00	1.00	1.00	0.09	infinite	6.02E-04	1.70E-10
003	1.00	1.00	1.00	1.00	1.00	1.00	0.08	infinite	5.33E-04	1.51E-10
004	1.00	1.00	1.00	1.00	1.00	1.00	0.06	infinite	7.38E-04	2.09E-10
005	1.00	1.00	1.00	1.00	1.00	1.00	0.13	infinite	2.85E-04	8.07E-11
006	1.00	1.00	1.00	1.00	1.00	1.00	0.11	infinite	3.47E-04	9.84E-11
007	1.00	1.00	1.00	1.00	1.00	1.00	0.09	infinite	3.51E-04	9.95E-11
008	1.00	1.00	1.00	1.00	1.00	1.00	0.10	infinite	9.02E-04	2.55E-10
009	1.00	1.00	1.00	1.00	1.00	1.00	0.07	infinite	8.75E-04	2.48E-10
010	1.00	1.00	1.00	1.00	1.00	1.00	0.05	infinite	4.20E-04	1.19E-10
011	1.00	1.00	1.00	1.00	1.00	1.00	0.06	infinite	2.09E-04	5.91E-11
012	1.00	1.00	1.00	1.00	1.00	1.00	0.06	infinite	6.59E-04	1.87E-10
013	1.00	1.00	1.00	1.00	1.00	1.00	0.08	infinite	7.87E-04	2.23E-10
014	1.00	1.00	1.00	1.00	1.00	1.00	0.05	infinite	6.35E-04	1.80E-10
015	1.00	1.00	1.00	1.00	1.00	1.00	0.10	infinite	6.43E-04	1.82E-10
016	1.00	1.00	1.00	1.00	1.00	1.00	0.04	infinite	3.16E-04	8.94E-11
017	1.00	1.00	1.00	1.00	1.00	1.00	0.07	infinite	7.18E-04	2.03E-10
018	1.00	1.00	1.00	1.00	1.00	1.00	0.06	infinite	5.37E-04	1.52E-10
019	1.00	1.00	1.00	1.00	1.00	1.00	0.17	infinite	8.23E-04	2.33E-10
020	1.00	1.00	1.00	1.00	1.00	1.00	0.16	infinite	2.69E-04	7.63E-11
021	1.00	1.00	1.00	1.00	1.00	1.00	0.03	infinite	2.81E-04	7.95E-11
022	1.00	1.00	1.00	1.00	1.00	1.00	0.08	infinite	4.10E-04	1.16E-10
023	1.00	1.00	1.00	1.00	1.00	1.00	0.06	infinite	1.38E-04	3.90E-11
024	1.00	1.00	1.00	1.00	1.00	1.00	0.03	infinite	9.77E-04	2.77E-10
025	1.00	1.00	1.00	1.00	1.00	1.00	0.10	infinite	5.22E-04	1.48E-10
026	1.00	1.00	1.00	1.00	1.00	1.00	0.03	infinite	3.07E-04	8.69E-11
027	1.00	1.00	1.00	1.00	1.00	1.00	0.09	infinite	6.43E-04	1.82E-10
028	1.00	1.00	1.00	1.00	1.00	1.00	0.04	infinite	3.80E-04	1.08E-10
029	1.00	1.00	1.00	1.00	1.00	1.00	0.19	infinite	9.52E-04	2.70E-10
030	1.00	1.00	1.00	1.00	1.00	1.00	0.12	infinite	8.54E-04	2.42E-10
031	1.00	1.00	1.00	1.00	1.00	1.00	0.07	infinite	5.51E-04	1.56E-10
032	1.00	1.00	1.00	1.00	1.00	1.00	0.06	infinite	5.93E-04	1.68E-10
033	1.00	1.00	1.00	1.00	1.00	1.00	0.04	infinite	5.45E-04	1.54E-10
034	1.00	1.00	1.00	1.00	1.00	1.00	0.05	infinite	2.20E-04	6.23E-11
035	1.00	1.00	1.00	1.00	1.00	1.00	0.09	infinite	5.15E-04	1.46E-10
036	1.00	1.00	1.00	1.00	1.00	1.00	0.27	infinite	4.16E-04	1.18E-10
037	1.00	1.00	1.00	1.00	1.00	1.00	0.06	infinite	2.50E-04	7.09E-11
038	1.00	1.00	1.00	1.00	1.00	1.00	0.07	infinite	9.68E-04	2.74E-10
039	1.00	1.00	1.00	1.00	1.00	1.00	0.10	infinite	5.88E-04	1.66E-10
040	1.00	1.00	1.00	1.00	1.00	1.00	0.06	infinite	8.88E-04	2.52E-10
041	1.00	1.00	1.00	1.00	1.00	1.00	0.08	infinite	9.33E-04	2.64E-10
042	1.00	1.00	1.00	1.00	1.00	1.00	0.07	infinite	8.65E-04	2.45E-10
043	1.00	1.00	1.00	1.00	1.00	1.00	0.07	infinite	7.92E-04	2.24E-10
044	1.00	1.00	1.00	1.00	1.00	1.00	0.06	infinite	4.39E-04	1.24E-10
045	1.00	1.00	1.00	1.00	1.00	1.00	0.12	infinite	1.99E-04	5.63E-11
046	1.00	1.00	1.00	1.00	1.00	1.00	0.14	infinite	7.84E-04	2.22E-10
047	1.00	1.00	1.00	1.00	1.00	1.00	0.05	infinite	7.05E-04	2.00E-10
048	1.00	1.00	1.00	1.00	1.00	1.00	0.07	infinite	6.20E-04	1.76E-10
049	1.00	1.00	1.00	1.00	1.00	1.00	0.13	infinite	3.56E-04	1.01E-10
050	1.00	1.00	1.00	1.00	1.00	1.00	0.03	infinite	7.07E-04	2.00E-10



Table C.17. SWMU 1 SESOIL Input Parameters Used in Probabilistic Modeling (Continued)

Run (#)	Layer 1 Conc (mg/kg)	Layer 2 Conc (mg/kg)	Layer 3 Conc (mg/kg)	Layer 4 Conc (mg/kg)	Layer 5 Conc (mg/kg)	Layer 6 Conc (mg/kg)	Organic Carbon (%)	Degradation Rate (/hr)	Vertical Hydraulic Conductivity (m/hr)	Intrinsic Permeability (cm <sup>2</sup> )
051	1.00	1.00	1.00	1.00	1.00	1.00	0.05	infinite	2.15E-04	6.07E-11
052	1.00	1.00	1.00	1.00	1.00	1.00	0.03	infinite	9.87E-04	2.80E-10
053	1.00	1.00	1.00	1.00	1.00	1.00	0.07	infinite	8.11E-04	2.30E-10
054	1.00	1.00	1.00	1.00	1.00	1.00	0.11	infinite	3.78E-04	1.07E-10
055	1.00	1.00	1.00	1.00	1.00	1.00	0.03	infinite	5.39E-04	1.52E-10
056	1.00	1.00	1.00	1.00	1.00	1.00	0.03	infinite	3.40E-04	9.64E-11
057	1.00	1.00	1.00	1.00	1.00	1.00	0.14	infinite	8.75E-04	2.48E-10
058	1.00	1.00	1.00	1.00	1.00	1.00	0.10	infinite	6.63E-04	1.88E-10
059	1.00	1.00	1.00	1.00	1.00	1.00	0.03	infinite	6.60E-04	1.87E-10
060	1.00	1.00	1.00	1.00	1.00	1.00	0.04	infinite	1.22E-04	3.45E-11
061	1.00	1.00	1.00	1.00	1.00	1.00	0.04	infinite	8.27E-04	2.34E-10
062	1.00	1.00	1.00	1.00	1.00	1.00	0.22	infinite	9.60E-04	2.72E-10
063	1.00	1.00	1.00	1.00	1.00	1.00	0.09	infinite	6.54E-04	1.85E-10
064	1.00	1.00	1.00	1.00	1.00	1.00	0.08	infinite	4.44E-04	1.26E-10
065	1.00	1.00	1.00	1.00	1.00	1.00	0.06	infinite	1.64E-04	4.64E-11
066	1.00	1.00	1.00	1.00	1.00	1.00	0.14	infinite	6.71E-04	1.90E-10
067	1.00	1.00	1.00	1.00	1.00	1.00	0.03	infinite	3.73E-04	1.06E-10
068	1.00	1.00	1.00	1.00	1.00	1.00	0.06	infinite	5.80E-04	1.64E-10
069	1.00	1.00	1.00	1.00	1.00	1.00	0.06	infinite	5.90E-04	1.67E-10
070	1.00	1.00	1.00	1.00	1.00	1.00	0.06	infinite	5.66E-04	1.60E-10
071	1.00	1.00	1.00	1.00	1.00	1.00	0.04	infinite	5.96E-04	1.69E-10
072	1.00	1.00	1.00	1.00	1.00	1.00	0.03	infinite	8.64E-04	2.45E-10
073	1.00	1.00	1.00	1.00	1.00	1.00	0.10	infinite	8.74E-04	2.47E-10
074	1.00	1.00	1.00	1.00	1.00	1.00	0.09	infinite	5.09E-04	1.44E-10
075	1.00	1.00	1.00	1.00	1.00	1.00	0.06	infinite	7.80E-04	2.21E-10
076	1.00	1.00	1.00	1.00	1.00	1.00	0.06	infinite	3.41E-04	9.65E-11
077	1.00	1.00	1.00	1.00	1.00	1.00	0.07	infinite	1.69E-04	4.78E-11
078	1.00	1.00	1.00	1.00	1.00	1.00	0.10	infinite	4.86E-04	1.38E-10
079	1.00	1.00	1.00	1.00	1.00	1.00	0.03	infinite	4.38E-04	1.24E-10
080	1.00	1.00	1.00	1.00	1.00	1.00	0.05	infinite	6.46E-04	1.83E-10
081	1.00	1.00	1.00	1.00	1.00	1.00	0.08	infinite	7.35E-04	2.08E-10
082	1.00	1.00	1.00	1.00	1.00	1.00	0.17	infinite	5.91E-04	1.67E-10
083	1.00	1.00	1.00	1.00	1.00	1.00	0.10	infinite	9.89E-05	2.80E-11
084	1.00	1.00	1.00	1.00	1.00	1.00	0.05	infinite	7.33E-04	2.08E-10
085	1.00	1.00	1.00	1.00	1.00	1.00	0.08	infinite	4.80E-04	1.36E-10
086	1.00	1.00	1.00	1.00	1.00	1.00	0.28	infinite	6.47E-04	1.83E-10
087	1.00	1.00	1.00	1.00	1.00	1.00	0.06	infinite	4.24E-04	1.20E-10
088	1.00	1.00	1.00	1.00	1.00	1.00	0.03	infinite	1.29E-04	3.66E-11
089	1.00	1.00	1.00	1.00	1.00	1.00	0.10	infinite	8.04E-04	2.28E-10
090	1.00	1.00	1.00	1.00	1.00	1.00	0.07	infinite	6.26E-04	1.77E-10
091	1.00	1.00	1.00	1.00	1.00	1.00	0.05	infinite	8.38E-04	2.37E-10
092	1.00	1.00	1.00	1.00	1.00	1.00	0.05	infinite	9.25E-04	2.62E-10
093	1.00	1.00	1.00	1.00	1.00	1.00	0.08	infinite	5.94E-04	1.68E-10
094	1.00	1.00	1.00	1.00	1.00	1.00	0.08	infinite	6.82E-04	1.93E-10
095	1.00	1.00	1.00	1.00	1.00	1.00	0.04	infinite	4.44E-04	1.26E-10
096	1.00	1.00	1.00	1.00	1.00	1.00	0.06	infinite	4.50E-04	1.27E-10
097	1.00	1.00	1.00	1.00	1.00	1.00	0.03	infinite	4.54E-04	1.29E-10
098	1.00	1.00	1.00	1.00	1.00	1.00	0.14	infinite	5.26E-04	1.49E-10
099	1.00	1.00	1.00	1.00	1.00	1.00	0.03	infinite	1.01E-03	2.87E-10
100	1.00	1.00	1.00	1.00	1.00	1.00	0.07	infinite	4.22E-04	1.20E-10

Table C.18. C-720 SESOIL Input Parameters Used in Probabilistic Modeling

Run (#)	Layer 1 Conc (mg/kg)	Layer 2 Conc (mg/kg)	Layer 3 Conc (mg/kg)	Layer 4 Conc (mg/kg)	Layer 5 Conc (mg/kg)	Layer 6 Conc (mg/kg)	Organic Carbon (%)	Degradation Rate (/hr)	Vertical Hydraulic Conductivity (m/hr)	Intrinsic Permeability (cm <sup>2</sup> )
001	1.00	1.00	1.00	1.00	1.00	1.00	0.07	infinite	2.09E-04	5.91E-11
002	1.00	1.00	1.00	1.00	1.00	1.00	0.06	infinite	6.59E-04	1.87E-10
003	1.00	1.00	1.00	1.00	1.00	1.00	0.06	infinite	7.87E-04	2.23E-10
004	1.00	1.00	1.00	1.00	1.00	1.00	0.05	infinite	6.35E-04	1.80E-10
005	1.00	1.00	1.00	1.00	1.00	1.00	0.19	infinite	6.43E-04	1.82E-10
006	1.00	1.00	1.00	1.00	1.00	1.00	0.10	infinite	3.16E-04	8.94E-11
007	1.00	1.00	1.00	1.00	1.00	1.00	0.09	infinite	1.07E-04	3.04E-11
008	1.00	1.00	1.00	1.00	1.00	1.00	0.07	infinite	6.04E-04	1.71E-10
009	1.00	1.00	1.00	1.00	1.00	1.00	0.11	infinite	2.69E-04	7.63E-11
010	1.00	1.00	1.00	1.00	1.00	1.00	0.03	infinite	6.43E-04	1.82E-10
011	1.00	1.00	1.00	1.00	1.00	1.00	0.03	infinite	2.81E-04	7.95E-11
012	1.00	1.00	1.00	1.00	1.00	1.00	0.05	infinite	4.10E-04	1.16E-10
013	1.00	1.00	1.00	1.00	1.00	1.00	0.07	infinite	1.38E-04	3.90E-11
014	1.00	1.00	1.00	1.00	1.00	1.00	0.13	infinite	9.77E-04	2.77E-10
015	1.00	1.00	1.00	1.00	1.00	1.00	0.21	infinite	5.22E-04	1.48E-10
016	1.00	1.00	1.00	1.00	1.00	1.00	0.05	infinite	9.21E-04	2.61E-10
017	1.00	1.00	1.00	1.00	1.00	1.00	0.03	infinite	3.07E-04	8.69E-11
018	1.00	1.00	1.00	1.00	1.00	1.00	0.05	infinite	6.43E-04	1.82E-10
019	1.00	1.00	1.00	1.00	1.00	1.00	0.11	infinite	3.80E-04	1.08E-10
020	1.00	1.00	1.00	1.00	1.00	1.00	0.19	infinite	9.52E-04	2.70E-10
021	1.00	1.00	1.00	1.00	1.00	1.00	0.12	infinite	8.54E-04	2.42E-10
022	1.00	1.00	1.00	1.00	1.00	1.00	0.07	infinite	5.51E-04	1.56E-10
023	1.00	1.00	1.00	1.00	1.00	1.00	0.06	infinite	5.93E-04	1.68E-10
024	1.00	1.00	1.00	1.00	1.00	1.00	0.04	infinite	5.45E-04	1.54E-10
025	1.00	1.00	1.00	1.00	1.00	1.00	0.05	infinite	2.20E-04	6.23E-11
026	1.00	1.00	1.00	1.00	1.00	1.00	0.09	infinite	5.15E-04	1.46E-10
027	1.00	1.00	1.00	1.00	1.00	1.00	0.27	infinite	4.16E-04	1.18E-10
028	1.00	1.00	1.00	1.00	1.00	1.00	0.06	infinite	2.50E-04	7.09E-11
029	1.00	1.00	1.00	1.00	1.00	1.00	0.06	infinite	9.68E-04	2.74E-10
030	1.00	1.00	1.00	1.00	1.00	1.00	0.04	infinite	5.88E-04	1.66E-10
031	1.00	1.00	1.00	1.00	1.00	1.00	0.07	infinite	8.88E-04	2.52E-10
032	1.00	1.00	1.00	1.00	1.00	1.00	0.08	infinite	9.33E-04	2.64E-10
033	1.00	1.00	1.00	1.00	1.00	1.00	0.07	infinite	8.65E-04	2.45E-10
034	1.00	1.00	1.00	1.00	1.00	1.00	0.06	infinite	7.92E-04	2.24E-10
035	1.00	1.00	1.00	1.00	1.00	1.00	0.06	infinite	4.39E-04	1.24E-10
036	1.00	1.00	1.00	1.00	1.00	1.00	0.12	infinite	1.99E-04	5.63E-11
037	1.00	1.00	1.00	1.00	1.00	1.00	0.03	infinite	7.84E-04	2.22E-10
038	1.00	1.00	1.00	1.00	1.00	1.00	0.05	infinite	7.05E-04	2.00E-10
039	1.00	1.00	1.00	1.00	1.00	1.00	0.07	infinite	6.20E-04	1.76E-10
040	1.00	1.00	1.00	1.00	1.00	1.00	0.13	infinite	3.56E-04	1.01E-10
041	1.00	1.00	1.00	1.00	1.00	1.00	0.03	infinite	7.07E-04	2.00E-10
042	1.00	1.00	1.00	1.00	1.00	1.00	0.09	infinite	2.15E-04	6.07E-11
043	1.00	1.00	1.00	1.00	1.00	1.00	0.15	infinite	9.87E-04	2.80E-10
044	1.00	1.00	1.00	1.00	1.00	1.00	0.07	infinite	8.11E-04	2.30E-10
045	1.00	1.00	1.00	1.00	1.00	1.00	0.04	infinite	3.78E-04	1.07E-10
046	1.00	1.00	1.00	1.00	1.00	1.00	0.13	infinite	5.39E-04	1.52E-10
047	1.00	1.00	1.00	1.00	1.00	1.00	0.03	infinite	3.40E-04	9.64E-11
048	1.00	1.00	1.00	1.00	1.00	1.00	0.14	infinite	8.75E-04	2.48E-10
049	1.00	1.00	1.00	1.00	1.00	1.00	0.04	infinite	6.63E-04	1.88E-10
050	1.00	1.00	1.00	1.00	1.00	1.00	0.03	infinite	6.60E-04	1.87E-10

Table C.18. C-720 SESOIL Input Parameters Used in Probabilistic Modeling (Continued)

Run (#)	Layer 1 Conc (mg/kg)	Layer 2 Conc (mg/kg)	Layer 3 Conc (mg/kg)	Layer 4 Conc (mg/kg)	Layer 5 Conc (mg/kg)	Layer 6 Conc (mg/kg)	Organic Carbon (%)	Degradation Rate (/hr)	Vertical Hydraulic Conductivity (m/hr)	Intrinsic Permeability (cm <sup>2</sup> )
051	1.00	1.00	1.00	1.00	1.00	1.00	0.04	infinite	1.22E-04	3.45E-11
052	1.00	1.00	1.00	1.00	1.00	1.00	0.04	infinite	8.27E-04	2.34E-10
053	1.00	1.00	1.00	1.00	1.00	1.00	0.09	infinite	9.60E-04	2.72E-10
054	1.00	1.00	1.00	1.00	1.00	1.00	0.06	infinite	4.44E-04	1.26E-10
055	1.00	1.00	1.00	1.00	1.00	1.00	0.06	infinite	1.64E-04	4.64E-11
056	1.00	1.00	1.00	1.00	1.00	1.00	0.14	infinite	6.71E-04	1.90E-10
057	1.00	1.00	1.00	1.00	1.00	1.00	0.15	infinite	3.73E-04	1.06E-10
058	1.00	1.00	1.00	1.00	1.00	1.00	0.08	infinite	5.80E-04	1.64E-10
059	1.00	1.00	1.00	1.00	1.00	1.00	0.07	infinite	5.90E-04	1.67E-10
060	1.00	1.00	1.00	1.00	1.00	1.00	0.06	infinite	5.66E-04	1.60E-10
061	1.00	1.00	1.00	1.00	1.00	1.00	0.11	infinite	5.96E-04	1.69E-10
062	1.00	1.00	1.00	1.00	1.00	1.00	0.15	infinite	8.64E-04	2.45E-10
063	1.00	1.00	1.00	1.00	1.00	1.00	0.04	infinite	8.74E-04	2.47E-10
064	1.00	1.00	1.00	1.00	1.00	1.00	0.09	infinite	5.09E-04	1.44E-10
065	1.00	1.00	1.00	1.00	1.00	1.00	0.07	infinite	7.80E-04	2.21E-10
066	1.00	1.00	1.00	1.00	1.00	1.00	0.06	infinite	3.41E-04	9.65E-11
067	1.00	1.00	1.00	1.00	1.00	1.00	0.06	infinite	1.69E-04	4.78E-11
068	1.00	1.00	1.00	1.00	1.00	1.00	0.05	infinite	4.86E-04	1.38E-10
069	1.00	1.00	1.00	1.00	1.00	1.00	0.17	infinite	4.38E-04	1.24E-10
070	1.00	1.00	1.00	1.00	1.00	1.00	0.05	infinite	6.46E-04	1.83E-10
071	1.00	1.00	1.00	1.00	1.00	1.00	0.06	infinite	7.35E-04	2.08E-10
072	1.00	1.00	1.00	1.00	1.00	1.00	0.03	infinite	5.91E-04	1.67E-10
073	1.00	1.00	1.00	1.00	1.00	1.00	0.10	infinite	9.89E-05	2.80E-11
074	1.00	1.00	1.00	1.00	1.00	1.00	0.08	infinite	7.33E-04	2.08E-10
075	1.00	1.00	1.00	1.00	1.00	1.00	0.06	infinite	4.80E-04	1.36E-10
076	1.00	1.00	1.00	1.00	1.00	1.00	0.06	infinite	6.47E-04	1.83E-10
077	1.00	1.00	1.00	1.00	1.00	1.00	0.35	infinite	4.24E-04	1.20E-10
078	1.00	1.00	1.00	1.00	1.00	1.00	0.05	infinite	3.06E-04	8.66E-11
079	1.00	1.00	1.00	1.00	1.00	1.00	0.05	infinite	8.04E-04	2.28E-10
080	1.00	1.00	1.00	1.00	1.00	1.00	0.06	infinite	6.26E-04	1.77E-10
081	1.00	1.00	1.00	1.00	1.00	1.00	0.09	infinite	8.38E-04	2.37E-10
082	1.00	1.00	1.00	1.00	1.00	1.00	0.05	infinite	9.25E-04	2.62E-10
083	1.00	1.00	1.00	1.00	1.00	1.00	0.08	infinite	5.94E-04	1.68E-10
084	1.00	1.00	1.00	1.00	1.00	1.00	0.06	infinite	6.82E-04	1.93E-10
085	1.00	1.00	1.00	1.00	1.00	1.00	0.12	infinite	4.44E-04	1.26E-10
086	1.00	1.00	1.00	1.00	1.00	1.00	0.08	infinite	4.50E-04	1.27E-10
087	1.00	1.00	1.00	1.00	1.00	1.00	0.17	infinite	4.54E-04	1.29E-10
088	1.00	1.00	1.00	1.00	1.00	1.00	0.14	infinite	5.26E-04	1.49E-10
089	1.00	1.00	1.00	1.00	1.00	1.00	0.03	infinite	1.01E-03	2.87E-10
090	1.00	1.00	1.00	1.00	1.00	1.00	0.07	infinite	4.22E-04	1.20E-10
091	1.00	1.00	1.00	1.00	1.00	1.00	0.08	infinite	1.02E-04	2.89E-11
092	1.00	1.00	1.00	1.00	1.00	1.00	0.07	infinite	4.35E-04	1.23E-10
093	1.00	1.00	1.00	1.00	1.00	1.00	0.03	infinite	6.87E-04	1.95E-10
094	1.00	1.00	1.00	1.00	1.00	1.00	0.14	infinite	6.68E-04	1.89E-10
095	1.00	1.00	1.00	1.00	1.00	1.00	0.10	infinite	3.34E-04	9.46E-11
096	1.00	1.00	1.00	1.00	1.00	1.00	0.06	infinite	4.72E-04	1.34E-10
097	1.00	1.00	1.00	1.00	1.00	1.00	0.09	infinite	7.38E-04	2.09E-10
098	1.00	1.00	1.00	1.00	1.00	1.00	0.11	infinite	1.02E-03	2.89E-10
099	1.00	1.00	1.00	1.00	1.00	1.00	0.09	infinite	2.67E-04	7.57E-11
100	1.00	1.00	1.00	1.00	1.00	1.00	0.09	infinite	6.45E-04	1.83E-10

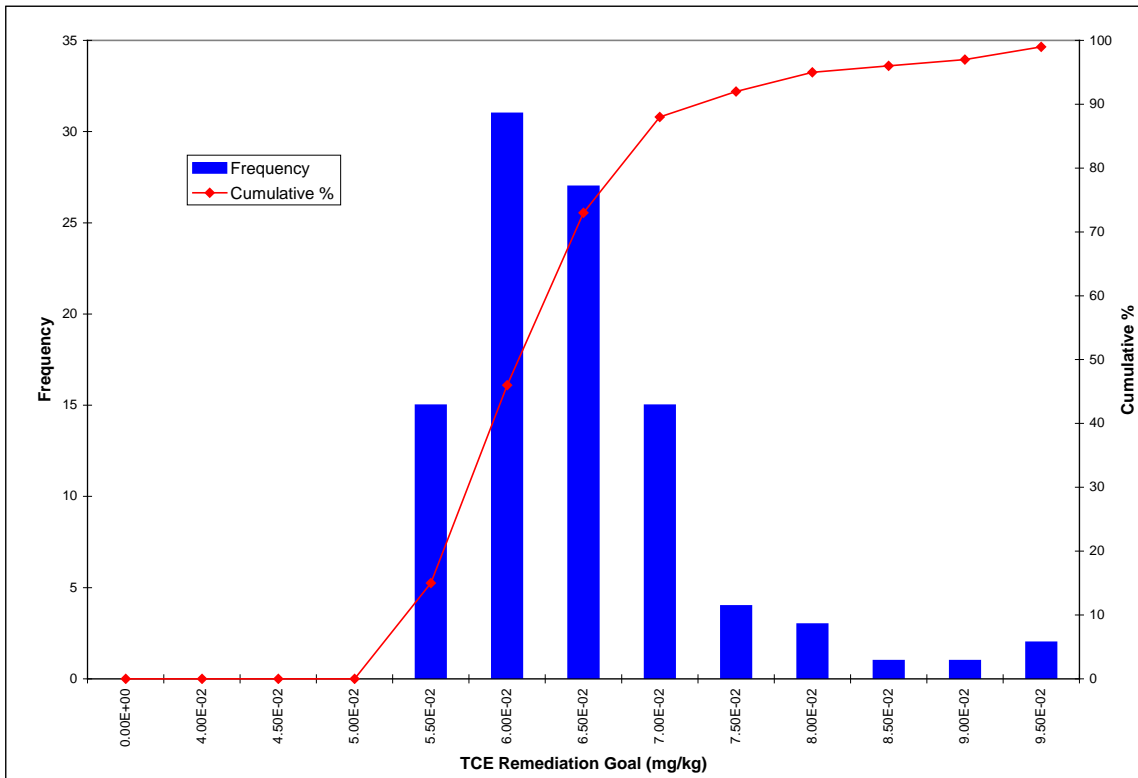

**Figure C.8. Histogram of SWMU 1 TCE RGs Based on the Maximum Predicted TCE Groundwater Concentrations**

**Table C.19. SWMU 1 TCE Remediation Goals Based on the 75% Quartile, Mean, Median, Geometric Mean, and 25% Quartile for Statistical Parameters Evaluated for the Maximum Groundwater Concentrations**

Result	Remediation Goal (mg/kg)
75% Quartile	0.065
Mean	0.062
Median	0.061
Geometric Mean	0.062
25% Quartile	0.057

The results of the uncertainty analysis for SWMU 1 indicate that the soil RG ranges from 0.057 to 0.065 mg/kg. Deterministic modeling assuming an infinite biological half-life resulted in a UCRS TCE soil RG of 0.063 mg/kg. The deterministic modeling TCE soil RG falls within the upper range of the probabilistically determined RGs and is greater than the median soil RG of 0.061 mg/kg shown in Table C.19.

#### C.4.4 C-720 TCE RESULTS

Figure C.9 provides a histogram of the remediation goals based on the maximum predicted groundwater concentrations for each of the 100 sets of input parameters. Table C.20 provides the soil remediation goals based on the 75% quartile, mean, median, geometric mean, and 25% quartile based on the maximum predicted groundwater concentrations for each of the 100 sets of input parameters.

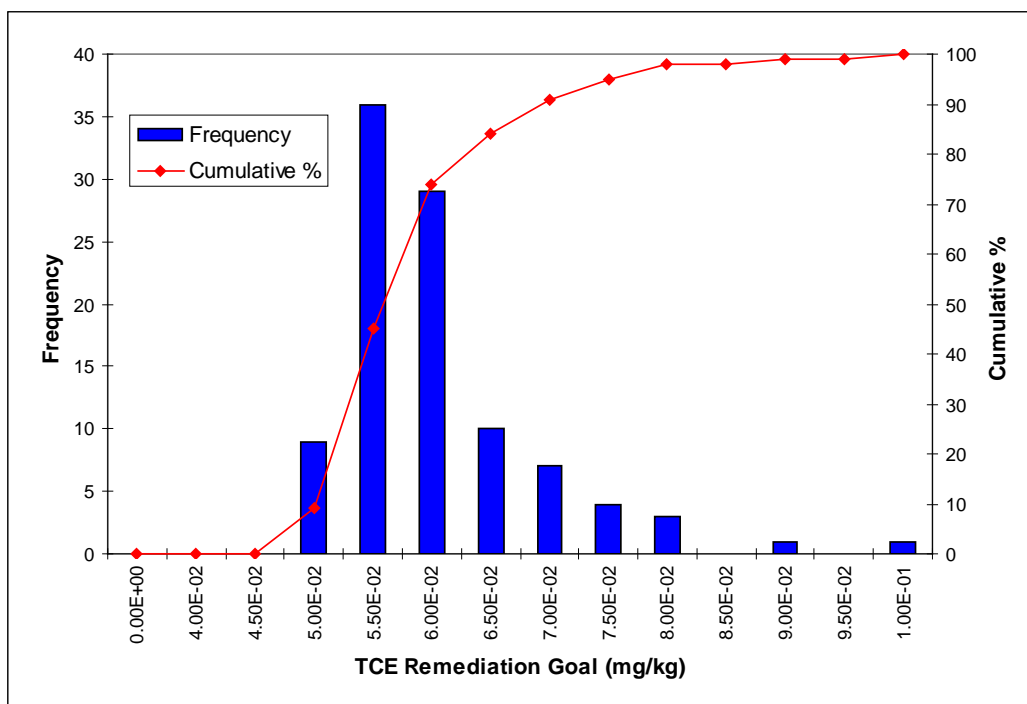

**Figure C.9. Histogram of C-720 TCE RGs Based on the Maximum Predicted TCE Groundwater Concentrations**

**Table C.20. C-720 TCE Remediation Goals Based on the 75% Quartile, Mean, Median, Geometric Mean, and 25% Quartile for Statistical Parameters Evaluated for the Maximum Groundwater Concentrations**

Result	Remediation Goal (mg/kg)
75% Quartile	0.060
Mean	0.058
Median	0.056
Geometric Mean	0.058
25% Quartile	0.053

The results of the uncertainty analysis for C-720 indicate that the soil RG ranges from 0.053 to 0.060 mg/kg. Deterministic modeling assuming an infinite biological half-life resulted in a UCRS TCE soil RG of 0.059 mg/kg. The deterministic modeling TCE soil RG falls within the upper range of the probabilistically determined RGs and is greater than the median soil RG of 0.056 mg/kg shown in Table C.19.

## C.5 SUMMARY AND CONCLUSIONS

Remedial evaluation results suggest the following:

- At SWMU 1, with the exception of *in situ* thermal treatment with a TCE five-year biological half-life, time to reach TCE MCLs in RGA groundwater will be decades after the conclusion of soil remediation, irrespective of treatment technology selected.
- At C-720, with the exception of *in situ* thermal treatment and *in situ* soil flushing with multiphase extraction and a TCE five-year biological half-life, time to reach TCE MCLs in RGA groundwater will be decades after the conclusion of soil remediation, irrespective of treatment technology selected.
- Variations in biological degradation half-life result in decades differences in predicted time to achieve the TCE MCL in RGA groundwater for individual remedial technologies.

## C.6 REFERENCES

- Brar, Gurdarshan S. 1996. *Evaluating the SESOIL Model for Benzene Leaching Assessment in Alaska, Special Report 96-11*, U.S. Army Corps of Engineers, Cold Regions Research & Engineering Laboratory.
- DOE (U.S. Department of Energy) 2007. *Site Investigation Report for the Southwest Groundwater Plume at the Paducah Gaseous Diffusion Plant, Paducah, Kentucky*, DOE/OR/07-2180&D2/R1, U.S. Department of Energy, Paducah, KY, June.
- DOE 2009. *Focused Feasibility Study for the Southwest Groundwater Plume Volatile Organic Compound Sources at the Paducah Gaseous Diffusion Plant, Paducah, Kentucky*, DOE/LX/07-0186&D1, U.S. Department of Energy, Paducah, KY, January.
- Odenchantz, Joseph E., John M. Farr, and Charles E. Robinson 1992. *Transport Model Sensitivity for Soil Cleanup Level Determinations Using SESOIL and AT123D in the Context of the California Leaking Underground Fuel Tank Field Manual*, *Journal of Soil Contamination*, 1(2):159-182.

**THIS PAGE INTENTIONALLY LEFT BLANK**

**APPENDIX D**

**BASELINE RISK ASSESSMENT FROM  
THE SOUTHWEST PLUME SI**



**THIS PAGE INTENTIONALLY LEFT BLANK**

## BASELINE RISK ASSESSMENT FROM THE SOUTHWEST PLUME SI

**PREVIOUS BASELINE RISK ASSESSMENT.** The Southwest Plume SI (DOE 2007) used historical information and newly collected data to develop a site model for each source area and presented a baseline risk assessment (BRA) that was conducted in two parts: the baseline human health risk assessment (BHHRA) and the screening ecological risk assessment (SERA). In these assessments, information collected during the Southwest Plume SI and results from previous risk assessments were used to characterize the baseline risks posed to human health and the environment resulting from contact with contaminants in groundwater drawn from the Southwest Plume in the Regional Gravel Aquifer (RGA) at the source areas. In addition, fate and transport modeling was conducted, and the BRA used these modeling results to estimate the future baseline risks that might be posed to human health and the environment through contact with groundwater impacted by contaminants migrating from the Oil Landfarm and C-720 Building Area to four points of exposure (POEs). The POEs assessed were at the source, the plant boundary, property boundary, and near the Ohio River. Vapor transport modeling was conducted, and the potential air concentrations used as the predicted household air concentrations for estimating excess lifetime cancer risk (ELCR) and hazard for the hypothetical future on and off-site rural resident.

Because data collected during the Southwest Plume SI focused on the collection of subsurface soil and groundwater data to delimit the potential sources of contamination to the Southwest Plume, new material developed in the BHHRA and SERA was limited to risks posed by contaminants from potential source areas to RGA groundwater and with direct contact with contaminated groundwater in the source areas. Risks from direct contact with other media at the potential sources (e.g., surface and subsurface soil, sediment, surface water, and McNairy Formation groundwater) and future industrial risk from use of contaminated groundwater were taken from the following assessments and studies.<sup>1</sup>

- *Results of the Public Health and Ecological Assessment, Phase II, at the Paducah Gaseous Diffusion Plant, Paducah, Kentucky, Vol. 6, in Results of the FFS, Phase II, at the Paducah Gaseous Diffusion Plant, Paducah, Kentucky* (CH2M HILL 1992).
- *Residual Risk Evaluation for Waste Area Grouping 23 and Solid Waste Management Unit 1 of Waste Area Grouping 27 at the Paducah Gaseous Diffusion Plant, Paducah, Kentucky* (DOE 1999).
- *Remedial Investigation Report for Waste Area Grouping 27 at the Paducah Gaseous Diffusion Plant, Paducah, Kentucky* (DOE 1999).
- *Feasibility Study for the Groundwater Operable Unit at the Paducah Gaseous Diffusion Plant, Paducah, Kentucky* (DOE 2001).
- *Contaminant Migration from SWMU 1 and the C-720 Area at the Paducah Gaseous Diffusion Plant, Paducah, Kentucky* (BJC 2003).

Consistent with the approved PGDP Risk Methods Documents (DOE 2001), the BHHRA reports risks for scenarios that encompass current use and several hypothetical future uses. The scenarios discussed in the BHHRA are as follows.

---

<sup>1</sup>Baseline risks taken from earlier reports are presented without modification in Section 2 of the BHHRA and in the SERA. Updated revisions of these risk estimates are presented in this section and in Section 7 of the BHHRA. Reasons for revising risk estimates are discussed in the BHHRA and include updated toxicity values and regulatory guidance.

- Current On-Site Industrial Use<sup>2</sup>—Direct contact with surface soil [soil found 0 to 0.3 m (0 to 1 ft) bgs], sediment, and surface water. Risk results presented in the BHHRA for this scenario were taken from assessments completed earlier.
- Future On-Site Industrial Use—Direct contact with surface soil, sediment, and surface water and groundwater use. Risk results presented in the BHHRA for this scenario were taken from assessments completed earlier.
- Future On-Site Excavation—Direct contact with surface and subsurface soil [soil 0 to 4.9 ms (0 to 16 ft) bgs]. Risk results presented in the BHHRA for this scenario were taken from assessments completed earlier.
- Future Recreational User—Direct contact with sediment and surface water and consumption of game exposed to contaminated surface soil. Risk results presented in the BHHRA for this scenario were taken from assessments completed earlier.
- Future Off-Site Recreational User—Direct contact with surface water impacted by contamination migrating from sources and consumption of game exposed to this surface water. Risk results presented in the BHHRA for this scenario were taken from assessments completed earlier.
- Future On-Site Rural Resident—Direct contact with surface soil at and use of groundwater drawn from the RGA and McNairy at source areas, including consumption of vegetables that are posited to be raised in these areas. Risk results presented in the BHHRA for use of RGA groundwater in the home as well as vapor intrusion into basement are newly derived from measured and modeled data with both results presented. Risk results presented in the BHHRA for other media were taken from assessments completed earlier.
- Future Off-Site Rural Resident—Use in the home of groundwater drawn from the RGA as well as vapor intrusion into basements at the DOE plant boundary, the DOE property boundary, and in a groundwater well at the Ohio River. Risk results for this receptor are newly derived from measured and modeled data, with both results presented in the BHHRA; however, risks estimated in earlier assessments for this receptor also are presented in the BHHRA.

Also consistent with the approved PGDP Risk Methods Documents (DOE 2001), the SERA reports the potential risks under both current and potential future conditions to ecological receptors that may come into contact with contaminated media at the potential source areas associated with the Southwest Plume. Because all new data collected during the FFS were from soil samples collected below 4.6 ms (15 ft) bgs or were groundwater samples, all results presented in the SERA are taken from earlier BERAs. Risk to the future industrial worker from uses of contaminated groundwater at the Oil Landfarm and the C-720 Building Area were derived in the WAG 27 RI (DOE 1999), which included all data collected from 1989 to completion of the WAG 27 project in 1999, and were not further evaluated in the Southwest Plume SI.

For two of the three potential sources discussed in the Southwest Plume SI BHHRA (i.e., Oil Landfarm and C-720 Building Area), the cumulative human health ELCRs and systemic toxicity (i.e., hazard) exceed the *de minimis* levels [i.e., a cumulative ELCR of  $1 \times 10^{-6}$  or a cumulative hazard index (HI) of 1 as defined in DOE 2001] in the PGDP Risk Methods Document for one or more scenarios. For the Storm Sewer, only the ELCR exceeded acceptable standards. The land uses and media assessed for ELCR and

---

<sup>2</sup>As noted earlier, the current industrial land use scenario assessed in the WAG 27 RI did not include or take into account existing DOE controls on worker exposures, such as controls on access to areas containing contaminated soils or sediment or the use of personal protective equipment (PPE).

HI for human health for each potential source area are presented in Table D.1. As shown, only results for groundwater use and vapor intrusion from groundwater by the hypothetical future on- and off-site rural residents are newly derived in the Southwest Plume SI BHHRA.

**Table D.1. Land Uses and Media Assessed for Each Source Area Included in the FFS for the Southwest Plume**

Scenario	Location		
	Oil Landfarm	C-720 Building Area	Storm Sewer
Current On-site Industrial Worker			
Surface Soil	P	NA	NA
Sediment <sup>a</sup>	P	NA	NA
Surface Water	NA	NA	NA
Future On-site Excavation Worker			
Surface and Subsurface Soil	P	P	NA
Future On-site Recreational User			
Game (Soil)	P	NA	NA
Sediment <sup>a</sup>	P	NA	NA
Surface Water	NA	NA	NA
Future Off-site Recreational User			
Surface Water	P	NA	NA
Game	NA	NA	NA
Future On-site Rural Resident			
Soil	P	NA	NA
Groundwater <sup>b</sup>	X	X	X
Vapor Intrusion <sup>d</sup>	X	X	NA
Future Off-site Rural Resident			
Groundwater <sup>c</sup>	X	X	X
Vapor Intrusion <sup>d</sup>	X	X	NA
Future On-site Terrestrial Biota			
Soil	P	NA	NA
Sediment <sup>a</sup>	P	NA	NA
Surface Water	NA	NA	NA

Notes: Scenarios that were assessed in the Southwest Plume SI BRA are marked with an X. Scenarios assessed in previous BRAs are marked with a P. Scenarios not assessed because the scenario is not applicable, or for which the medium is not present, are marked with an NA.

Table adapted from SI for the Southwest Groundwater Plume (DOE 2007).

<sup>a</sup>Sediment considered in earlier assessments was in ditches surrounding the source area.

<sup>b</sup>The earlier BHHRA assessed risks from use of water drawn from the RGA separately from use of water drawn from the McNairy Formation. The risks assessed in the Southwest Plume SI BRA are for use of water drawn from the RGA.

<sup>c</sup>Modeling results were used to assess risk to the off-site rural resident in the Southwest Plume SI. POEs are at the PGDP plant boundary, at the PGDP property boundary, and in a groundwater well at the Ohio River.

<sup>d</sup>Vapor intrusion was modeled for residential basements for TCE, 1,2-DCE, and VC only, as these COCs and antimony are identified in the WAG 27 RI as migrating from sources at the Oil Landfarm and the C-720 Building Area and result in risks above *de minimis* levels. Monitoring results document that TCE and its degradation products are the primary COCs that define the Southwest Plume. Antimony was not included in vapor intrusion modeling because it is not a volatile compound.

The scenarios for which risk exceeds *de minimis* levels are summarized in Table D.2. Information is taken from a series of risk summary tables presented at the end of this section [i.e., Tables D.3 through D.5, which present cumulative risk values for each scenario, the contaminants of concern (COCs), and the pathways of concern (POCs)].

**Table D.2. Scenarios for Which Human Health Risk Exceeds *De Minimis* Levels<sup>a</sup>**

Scenario	Location		
	Oil Landfarm	C-720 Building Area	Storm Sewer
<b>Results for Excess Lifetime Cancer Risk:</b>			
Current On-site Industrial Worker			
Exposure to Soil	NA	NA	NA
Exposure to Sediment	X	NA	NA
Exposure to Surface Water	NA	NA	NA
Future On-site Industrial Worker			
Exposure to Soil	NA	NA	NA
Exposure to Sediment	X	NA	NA
Exposure to Surface Water	NA	NA	NA
Exposure to Groundwater	X	X	NA
Future On-site Excavation Worker			
Exposure to Soil	X	---	NA
Future On-site Recreational User			
Exposure to Game	---	NA	NA
Exposure to Sediment	X	NA	NA
Exposure to Surface Water	NA	NA	NA
Future Off-site Recreational User			
Exposure to Surface Water	---	NA	NA
Exposure to Game	---	NA	NA
Future On-site Rural Resident			
Exposure to Soil	---	NA	NA
Exposure to Groundwater <sup>b</sup>	X	X	X
Vapor Intrusion <sup>e</sup>	X	X	NA
Future Off-site Rural Resident			
Exposure to Groundwater <sup>d</sup>	X	X	---
Vapor Intrusion <sup>e</sup>	---	---	NA
<b>Results for Systemic Toxicity<sup>c</sup>:</b>			
Current On-site Industrial Worker			
Exposure to Soil	NA	NA	NA
Exposure to Sediment	X	NA	NA
Exposure to Surface Water	NA	NA	NA
Future On-site Industrial Worker			
Exposure to Soil	NA	NA	NA
Exposure to Sediment	X	NA	NA
Exposure to Surface Water	NA	NA	NA

**Table D.2. Scenarios for Which Human Health Risk Exceeds *De Minimis* Levels<sup>a</sup> (Continued)**

Scenario	Location		
	Oil Landfarm	C-720 Building Area	Storm Sewer
Future On-site Excavation Worker			
Exposure to Soil	X	X	NA
Future On-site Recreational User			
Exposure to Game	---	NA	NA
Exposure to Sediment	X	NA	NA
Exposure to Surface Water	NA	NA	NA
Future Off-site Recreational User			
Exposure to Surface Water	---	NA	NA
Exposure to Game	---	NA	NA
Future On-site Rural Resident			
Exposure to Soil	---	NA	NA
Exposure to Groundwater <sup>b</sup>	X	X	---
Vapor Intrusion <sup>e</sup>	X	X	NA
Future Off-site Rural Resident			
Exposure to Groundwater <sup>d</sup>	---	---	---
Vapor Intrusion <sup>e</sup>	---	---	NA

Notes: Scenarios where risk exceeds *de minimis* levels are marked with an X. Scenarios where risk did not exceed *de minimis* levels are marked with a ---. NA indicates that the scenario/land use combination was not assessed because the scenario is not applicable, or the medium is not present.

Table adapted from SI for the Southwest Groundwater Plume (DOE 2007).

<sup>a</sup>Consistent with the PGDP Risk Methods Document (DOE 2001b), the *de minimis* levels used are a cumulative ELCR of  $1 \times 10^{-6}$  or a cumulative Hazard Index (HI) of 1.

<sup>b</sup>The BHHRA assessed risks from use of water drawn from the RGA separately from use of water drawn from the McNairy Formation. The value reported here is for use of water from the RGA.

<sup>c</sup>Systemic toxicity results summarized here for the resident and recreational user are for the child. The off-site POE considered is the property boundary.

<sup>d</sup>Based on results of preliminary deterministic and probabilistic contaminant transport modeling. The POE is the property boundary. X indicates that the location contains a source of unacceptable off-site contamination, and --- indicates that the location is not a source of off-site contamination (see Tables G.72 and G.73 in the Southwest Plume SI).

<sup>e</sup>Vapor intrusion was modeled for residential basements for TCE, 1,2-DCE, and VC only, as these COCs and antimony are identified in the WAG 27 RI as migrating from sources at the Oil Landfarm and the C-720 Building Area and result in risks above *de minimis* levels. Monitoring results document that TCE and its degradation products are the primary COCs that define the Southwest Plume. Antimony was not included in vapor intrusion modeling because it is not a volatile compound.

**Table D.3. Summary of Risk Characterization for the Oil Landfarm<sup>a</sup>**

Receptor	Total ELCR <sup>a</sup>	COCs	% Total ELCR	POCs	% Total ELCR	Total HI <sup>a</sup>	COCs	% Total HI	POCs	% Total HI
Current industrial worker at current concentrations <sup>b</sup> (soil)	NE	NE	NE	NE	NE	NE	NE	NE	NE	NE
Future industrial worker at current concentrations <sup>b</sup> (soil)	NE	NE	NE	NE	NE	NE	NE	NE	NE	NE
Current industrial worker at current concentrations (sediment)	3.4 × 10 <sup>-5</sup>	Arsenic Cesium-137 Neptunium-237 Uranium Uranium-235	27 11 48 6 3	Ingestion of sediment Dermal contact External exposure	5 26 69	1.7	Chromium Iron Manganese Vanadium	16 23 25 23	Dermal contact	99
Future industrial worker at current concentrations (sediment only)	3.4 × 10 <sup>-5</sup>	Arsenic Cesium-137 Neptunium-237 Uranium Uranium-238	27 11 48 6 3	Ingestion of sediment Dermal contact External exposure	5 26 69	1.7	Chromium Iron Manganese Vanadium	16 23 25 23	Dermal contact	99
Future industrial worker at current concentrations (RGA groundwater)	1.9 × 10 <sup>-3</sup>	Arsenic Beryllium 1,1-dichloroethene Bis(2-ethylhexyl)phthalate Trichloroethene Americium-241 Cesium-137 Neptunium-237 Radon-222 Technetium-99 Uranium-235 Uranium-238	53 10 1 <1 <1 3 <1 2 25 <1 <1 4	Ingestion of groundwater; Dermal contact; Inhalation while showering	71 3 26	14.2	Aluminum Antimony Arsenic Barium Chromium Iron Manganese Vanadium Trichloroethene	4 1 45 1 1 18 21 3 1	Ingestion of groundwater Dermal contact	95 5

Table D.3. Summary of Risk Characterization for the Oil Landfarm <sup>a</sup> (Continued)

Receptor	Total ELCR <sup>a</sup>	COCs	% Total ELCR	POCs	% Total ELCR	Total HI <sup>a</sup>	COCs	% Total HI	POCs	% Total HI
Future industrial worker at current concentrations (McNairy groundwater)	3.9 × 10 <sup>4</sup>	Arsenic Beryllium Americium-241 Cesium-137 Uranium-235 Uranium-238	6 15 36 <1 <1 41	Ingestion of groundwater; Dermal contact	96 4	2.99	Arsenic Iron Manganese Uranium Vanadium	5 58 9 12 7	Ingestion of groundwater Dermal contact	95 5
Future child rural resident at current concentrations (RGA groundwater only)	NA	NA	NA	NA	NA	99	Arsenic Barium Cobalt Iron Manganese Nickel Chloroform Trichloroethene <i>cis</i> -1,2-Dichloroethene	1 <1 <1 1 11 <1 11 71 3	Ingestion of groundwater Dermal contact Inhalation while showering Inhalation household use Vapor Intrusion	23 2 6 44 22
Future child rural resident at current concentrations <sup>c</sup> (McNairy groundwater)	NA	NA	NA	NA	NA	20	Aluminum Arsenic Barium Beryllium Chromium Iron Manganese Nickel Uranium Vanadium Trichloroethene	2 5 1 <1 2 58 9 <1 12 6 2	Ingestion of groundwater Dermal contact Inhalation household use	96 2 2



**Table D.3. Summary of Risk Characterization for the Oil Landfarm <sup>a</sup> (Continued)**

<b>Receptor</b>	<b>Total ELCR<sup>a</sup></b>	<b>COCs</b>	<b>% Total ELCR</b>	<b>POCs</b>	<b>% Total ELCR</b>	<b>Total HI<sup>a</sup></b>	<b>COCs</b>	<b>% Total HI</b>	<b>POCs</b>	<b>% Total HI</b>	
Future adult rural resident at current concentrations (RGA groundwater only)	6.8 × 10 <sup>4</sup>	Arsenic	18	Ingestion of groundwater	43	26	Arsenic	2	Ingestion of groundwater	37	
		1,1-Dichloroethene	2	Dermal contact	4		Barium	<1	Dermal contact	4	
		Chloroform	2	Inhalation while showering	5		Iron	2	Inhalation while showering	5	
		Trichloroethene	74	Inhalation household use	36		Manganese	18	Inhalation household use	36	
		Technetium-99	<1	Vapor Intrusion	11		Nickel	<1	Vapor Intrusion	18	
								Chloroform	9		
								Trichloroethene	64		
					<i>cis</i> -1,2-Dichloroethene	3					
Future adult rural resident at current concentrations <sup>c</sup> (McNairy groundwater)	1.4 × 10 <sup>3</sup>	Arsenic	9	Ingestion of groundwater	100	8.2	Aluminum	2	Ingestion of groundwater	97	
		Trichloroethene	<1	Inhalation household use	<1		Arsenic	5	Dermal contact	3	
		Americium-241	42				Barium	1			
		Cesium-137	<1				Chromium	2			
		Uranium-235	<1				Iron	58			
		Uranium-238	47				Manganese	9			
					Uranium	12					
					Vanadium	6					
					Trichloroethene	1					

**Table D.3. Summary of Risk Characterization for the Oil Landfarm <sup>a</sup> (Continued)**

<b>Receptor</b>	<b>Total ELCR<sup>a</sup></b>	<b>COCs</b>	<b>% Total ELCR</b>	<b>POCs</b>	<b>% Total ELCR</b>	<b>Total HI<sup>a</sup></b>	<b>COCs</b>	<b>% Total HI</b>	<b>POCs</b>	<b>% Total HI</b>
Future child rural resident at modeled concentrations (RGA groundwater drawn at property boundary variable degradation)	NA	NA	NA	NA	NA	0.4	Trichloroethene <i>cis</i> -1,2-Dichloroethene	56 29	NE	NE
Future child rural resident at modeled concentrations (RGA groundwater drawn at property boundary fixed degradation)	NA	NA	NA	NA	NA	1.4	Trichloroethene <i>cis</i> -1,2-Dichloroethene	83 10	NE	NE
Future adult rural resident at modeled concentrations (RGA groundwater drawn at property boundary variable degradation)	$1.4 \times 10^{-6}$	Trichloroethene Vinyl chloride	39 61	Not determined	---	0.1	NE	NE	NE	NE
Future adult rural resident at modeled concentrations (RGA groundwater drawn at property boundary fixed degradation)	$6.1 \times 10^{-6}$	Trichloroethene Vinyl chloride	87 14	Not determined	---	0.2	NE	NE	NE	NE
Future child recreational user at current concentrations (soil)	NA	NA	NA	NA	NA	NE	NE	NE	NE	NE

**Table D.3. Summary of Risk Characterization for the Oil Landfarm <sup>a</sup> (Continued)**

<b>Receptor</b>	<b>Total ELCR<sup>a</sup></b>	<b>COCs</b>	<b>% Total ELCR</b>	<b>POCs</b>	<b>% Total ELCR</b>	<b>Total HI<sup>a</sup></b>	<b>COCs</b>	<b>% Total HI</b>	<b>POCs</b>	<b>% Total HI</b>
Future child recreational user at current concentrations (sediment)	NA	NA	NA	NA	NA	3.4	Aluminum Arsenic Chromium Iron Manganese Vanadium	7 4 19 28 10 28	Dermal contact	98
Future teen recreational user at current concentrations (soil)	NA	NA	NA	NA	NA	NE	NE	NE	NE	NE
Future teen recreational user at current concentrations (sediment)	NA	NA	NA	NA	NA	2.2	Aluminum Chromium Iron Manganese Vanadium	6 19 28 10 28	Dermal contact	99
Future adult recreational user at current concentrations (soil)	NE	NE	NE	NE	NE	NE	NE	NE	NE	NE
Future adult recreational user at current concentrations (sediment)	$1.9 \times 10^{-5}$	Arsenic Neptunium-237	78 10	Ingestion of sediment Dermal contact External exposure	9 74 13	0.5	NE	NE	NE	NE

**Table D.3. Summary of Risk Characterization for the Oil Landfarm <sup>a</sup> (Continued)**

Receptor	Total ELCR <sup>a</sup>	COCs	% Total ELCR	POCs	% Total ELCR	Total HI <sup>a</sup>	COCs	% Total HI	POCs	% Total HI
Future excavation worker at current concentrations	1.3 × 10 <sup>4</sup>	Arsenic	18	Ingestion of soil	24	1.9	Arsenic	7	Ingestion of soil	17
		PAHs	25	Dermal contact	54		Chromium	16	Dermal contact	74
		Bis(2-chloroethyl)ether	1	Inhalation of	6		Manganese	14	Inhalation of VOCs and particulates	9
		Dieldrin	1	VOCs and particulates	6		Vanadium	14		
		Heptachlorodibenzofuran	3	External exposure			2-Nitroaniline	12		
		Hexachlorobenzene	2				PCBs	7		
		N-Nitroso-di-n-propylamine	12				Trichloroethene	6		
		PCBs	2				<i>cis</i> -1,2-dichloroethene	7		
		Trichloroethene	12							
		Vinyl chloride	1							
		Cobalt-60	5							
		Uranium								

Note: NA = ELCR not applicable to child and teen cohorts. ELCR for adult is for lifetime exposure and takes into account exposure as child and teen.

NE = Land use scenario not of concern or land use not evaluated because contact with medium is not possible.

Table adapted from SI for the Southwest Groundwater Plume (DOE 2007).

<sup>a</sup>Total ELCR and total HI columns reflect values from BHHRA completed earlier and as part of the Southwest Plume SI.

<sup>b</sup>A response action for the Oil Landfarm has addressed PCBs and dioxins surface soil. Please see the BHHRA in Southwest Plume SI for additional information.

<sup>c</sup>In the earlier assessments, ELCR and hazard from exposure to groundwater water drawn from the RGA and McNairy were assessed. In the Southwest Plume SI BHHRA, results for use of water drawn from the RGA were reassessed, and the results for use of water drawn from the McNairy were recalculated for the residential scenario.

<sup>d</sup>Based on results of preliminary deterministic and probabilistic contaminant transport modeling (see Tables G.72 and G.73 in the Southwest Plume SI).

<sup>e</sup>Vapor intrusion was modeled for residential basements for TCE, 1,2-DCE, and VC only, as these COCs and antimony are identified in the WAG 27 RI as migrating from sources at the Oil Landfarm and the C-720 Building Area and result in risks above *de minimis* levels. Monitoring results document that TCE and its degradation products are the primary COCs that define the Southwest Plume. Antimony was not included in vapor intrusion modeling because it is not a volatile compound.

**Table D.4. Summary of Risk Characterization for C-720 Building Area<sup>a</sup>**

<b>Receptor</b>	<b>Total ELCR<sup>a</sup></b>	<b>COCs</b>	<b>% Total ELCR</b>	<b>POCs</b>	<b>% Total ELCR</b>	<b>Total HI<sup>a</sup></b>	<b>COCs</b>	<b>% Total HI</b>	<b>POCs</b>	<b>% Total HI</b>
Current industrial worker at current concentrations <sup>b</sup> (soil)	NE	NE	NE	NE	NE	NE	NE	NE	NE	NE
Future industrial worker at current concentrations <sup>b</sup> (soil)	NE	NE	NE	NE	NE	NE	NE	NE	NE	NE
Current industrial worker at current concentrations <sup>b</sup> (sediment)	NE	NE	NE	NE	NE	NE	NE	NE	NE	NE
Future industrial worker at current concentrations <sup>b</sup> (sediment)	NE	NE	NE	NE	NE	NE	NE	NE	NE	NE
Future industrial worker at current concentrations (RGA groundwater)	6.0 × 10 <sup>-4</sup>	Arsenic Beryllium 1,1-dichloroethene Carbon tetrachloride Tetrachloroethene Trichloroethene Vinyl chloride Americium-241 Cesium-137 Neptunium-237 Plutonium-239/240 Technetium-99 Thorium-230 Uranium-235 Uranium-238	1 10 4 <1 <1 2 <1 23 <1 12 <1 <1 <1 6 38	Ingestion of groundwater; Dermal contact; Inhalation while showering	94 3 3	3.03	Antimony Iron Manganese Carbon tetrachloride Trichloroethene	6 45 11 6 17	Ingestion of groundwater Dermal contact Inhalation while showering	85 8 7

**Table D.4. Summary of Risk Characterization for C-720 Building Area<sup>a</sup> (Continued)**

<b>Receptor</b>	<b>Total ELCR<sup>a</sup></b>	<b>COCs</b>	<b>% Total ELCR</b>	<b>POCs</b>	<b>% Total ELCR</b>	<b>Total HI<sup>a</sup></b>	<b>COCs</b>	<b>% Total HI</b>	<b>POCs</b>	<b>% Total HI</b>
Future industrial worker at current concentrations (McNairy groundwater)	$6.6 \times 10^{-4}$	Arsenic Beryllium 1,1-dichloroethene Vinyl chloride Americium-241 Cesium-137 Neptunium-237 Uranium-235 Uranium-238	<1 30 2 <1 19 <1 11 4 32	Ingestion of groundwater; Dermal contact; Inhalation while showering	91 8 <1	9.75	Aluminum Chromium Iron Manganese Vanadium	9 3 72 6 7	Ingestion of groundwater Dermal contact	95 5
Future child rural resident at current concentrations (RGA groundwater only)	NA	NA	NA	NA	NA	102	Arsenic Barium Iron Manganese Nickel 1,1-Dichloroethene Trichloroethene <i>cis</i> -1,2-Dichloroethene <i>trans</i> -1,2-Dichloroethene	1 <1 7 12 2 2 73 1 <1	Ingestion of groundwater Dermal contact Inhalation while showering Inhalation household use Vapor Intrusion	43 2 7 48 5
Future child rural resident at current concentrations <sup>c</sup> (McNairy groundwater)	NA	NA	NA	NA	NA	64.4	Aluminum Arsenic Barium Beryllium Chromium Iron Manganese Nickel Uranium Vanadium 1,1-Dichloroethene Trichloroethene	9 <1 <1 <1 3 73 6 <1 <1 6 <1 <1	Ingestion of groundwater Dermal contact Inhalation during household use	97 2 <1

**Table D.4. Summary of Risk Characterization for C-720 Building Area<sup>a</sup> (Continued)**

<b>Receptor</b>	<b>Total ELCR<sup>a</sup></b>	<b>COCs</b>	<b>% Total ELCR</b>	<b>POCs</b>	<b>% Total ELCR</b>	<b>Total HI<sup>a</sup></b>	<b>COCs</b>	<b>% Total HI</b>	<b>POCs</b>	<b>% Total HI</b>
Future adult rural resident at current concentrations (RGA groundwater only)	$1.8 \times 10^{-3}$	Arsenic 1,1-Dichloroethene Trichloroethene Vinyl chloride Technetium-99	7 64 24 5 <1	Ingestion of groundwater; Dermal contact; Inhalation while showering; Inhalation household use; Vapor Intrusion	53 2 5 38 2	23	Arsenic Barium Iron Manganese Nickel 1,1-Dichloroethene Trichloroethene <i>cis</i> -1,2-Dichloroethene	2 <1 12 22 4 2 53 2	Ingestion of groundwater Dermal contact Inhalation while showering Inhalation household use Vapor Intrusion	56 4 4 31 3
Future adult rural resident at current concentrations <sup>c</sup> (McNairy groundwater)	$2.2 \times 10^{-3}$	Arsenic 1,1-Dichloroethene Trichloroethene Vinyl chloride Americium-241 Cesium-137 Neptunium-237 Technetium-99 Uranium-235 Uranium-238	2 12 <1 1 24 <1 14 <1 6 40	Ingestion of groundwater; Dermal contact; Inhalation while showering; Inhalation household use	54 2 5 39	26.7	Aluminum Arsenic Barium Beryllium Chromium Iron Manganese Nickel Uranium Vanadium Trichloroethene	9 <1 <1 <1 3 73 6 <1 <1 6 <1	Ingestion of groundwater Dermal contact	97 3
Future child rural resident at modeled concentrations (RGA groundwater drawn at property boundary variable degradation)	NA	NA	NA	NA	NA	<0.1	NE	NE	NE	NE
Future child rural resident at modeled concentrations (RGA groundwater drawn at property boundary fixed degradation)	NA	NA	NA	NA	NA	0.3	Trichloroethene <i>cis</i> -1,2-Dichloroethene	69 30	NE	NE

**Table D.4. Summary of Risk Characterization for C-720 Building Area<sup>a</sup> (Continued)**

<b>Receptor</b>	<b>Total ELCR<sup>a</sup></b>	<b>COCs</b>	<b>% Total ELCR</b>	<b>POCs</b>	<b>% Total ELCR</b>	<b>Total HI<sup>a</sup></b>	<b>COCs</b>	<b>% Total HI</b>	<b>POCs</b>	<b>% Total HI</b>
Future adult rural resident at modeled concentrations (RGA groundwater drawn at property boundary variable degradation)	$1.1 \times 10^{-6}$	Vinyl chloride	>95	Not determined	---	<0.1	NE	NE	NE	NE
Future adult rural resident at modeled concentrations (RGA groundwater drawn at property boundary fixed degradation)	$2.4 \times 10^{-6}$	Trichloroethene Vinyl chloride	51 48	Not determined	---	0.2	Trichloroethene <i>cis</i> -1,2-Dichloroethene	82 11	NE	NE
Future child rural resident at current concentrations <sup>b</sup> (soil)	NA	NA	NA	NA	NA	NE	NE	NE	NE	NE
Future adult rural resident at current concentrations <sup>b</sup> (soil)	NE	NE	NE	NE	NE	NE	NE	NE	NE	NE
Future child recreational user at current concentrations <sup>b</sup> (soil)	NA	NA	NA	NA	NA	NE	NE	NE	NE	NE
Future child recreational user at current concentrations <sup>b</sup> (sediment)	NA	NA	NA	NA	NA	NE	NE	NE	NE	NE
Future teen recreational user at current concentrations <sup>b</sup> (soil)	NA	NA	NA	NA	NA	NE	NE	NE	NE	NE



**Table D.4. Summary of Risk Characterization for C-720 Building Area<sup>a</sup> (Continued)**

<b>Receptor</b>	<b>Total ELCR<sup>a</sup></b>	<b>COCs</b>	<b>% Total ELCR</b>	<b>POCs</b>	<b>% Total ELCR</b>	<b>Total HI<sup>a</sup></b>	<b>COCs</b>	<b>% Total HI</b>	<b>POCs</b>	<b>% Total HI</b>
Future teen recreational user at current concentrations <sup>b</sup> (sediment)	NA	NA	NA	NA	NA	NE	NE	NE	NE	NE
Future adult recreational user at current <sup>b</sup> concentrations (soil)	NE	NE	NE	NE	NE	NE	NE	NE	NE	NE
Future adult recreational user at current concentrations <sup>b</sup> (sediment)	NE	NE	NE	NE	NE	NE	NE	NE	NE	NE
Future excavation worker at current concentrations	1.5 × 10 <sup>-5</sup>	Arsenic Vinyl chloride	59 33	Ingestion of soil Dermal contact Inhalation of VOCs and particulates	37 46 12	0.4	NE	NE	NE	NE

Note: NA = ELCR not applicable to child and teen cohorts. ELCR for adult is for lifetime exposure and takes into account exposure as child and teen.

Table adapted from SI for the Southwest Groundwater Plume (DOE 2007).

NE = Land use scenario not of concern or land use not evaluated because contact with medium is not possible.

<sup>a</sup>Total ELCR and total HI columns reflect values from BHHRA completed earlier and as part of the Southwest Plume SI.

<sup>b</sup>The area around the C-720 Building is covered by gravel and cement; therefore, contact with surface soil is not possible. Please see the Southwest Plume SI BHHRA for additional information.

<sup>c</sup>In the earlier assessments, ELCR and hazard from exposure to groundwater water drawn from the RGA and McNairy were assessed. In the Southwest Plume SI BHHRA, only results for use of water drawn from the RGA were reassessed, and the results for use of water drawn from the McNairy were recalculated for the residential scenario.

<sup>d</sup>Based on results of preliminary deterministic and probabilistic contaminant transport modeling (see Tables G.72 and G.73 in the Southwest Plume SI).

**Table D.5. Summary of Risk Characterization for the Storm Sewer<sup>a</sup>**

<b>Receptor</b>	<b>Total ELCR<sup>a</sup></b>	<b>COCs</b>	<b>% Total ELCR</b>	<b>POCs</b>	<b>% Total ELCR</b>	<b>Total HI<sup>a</sup></b>	<b>COCs</b>	<b>% Total HI</b>	<b>POCs</b>	<b>%Total HI</b>
Current industrial worker at current concentrations <sup>b</sup> (soil)	NE	NE	NE	NE	NE	NE	NE	NE	NE	NE
Future industrial worker at current concentrations <sup>b</sup> (soil)	NE	NE	NE	NE	NE	NE	NE	NE	NE	NE
Current industrial worker at current concentrations <sup>b</sup> (sediment)	NE	NE	NE	NE	NE	NE	NE	NE	NE	NE
Future industrial worker at current concentrations <sup>b</sup> (sediment)	NE	NE	NE	NE	NE	NE	NE	NE	NE	NE
Future child rural resident at current concentrations <sup>c</sup> (RGA groundwater)	NA	NA	NA	NA	NA	0.6	NE	NE	NE	NE
Future child rural resident at current concentrations <sup>c</sup> (McNairy groundwater)	NE	NE	NE	NE	NE	NE	NE	NE	NE	NE
Future adult rural resident at current concentrations <sup>c</sup> (RGA groundwater)	$7.9 \times 10^{-6}$	1,1-dichloroethene Trichloroethene	27 73	Ingestion of groundwater Inhalation household use	41 48	0.2	NE	NE	NE	NE
Future adult rural resident at current concentrations <sup>c</sup> (McNairy groundwater )	NE	NE	NE	NE	NE	NE	NE	NE	NE	NE
Future child rural resident at modeled concentrations <sup>d</sup> (RGA groundwater drawn at plant boundary)	NA	NA	NA	NA	NA	NE	NE	NE	NE	NE
Future adult rural resident at modeled concentrations <sup>d</sup> (RGA groundwater drawn at plant boundary)	NE	NE	NE	NE	NE	NE	NE	NE	NE	NE
Future child rural resident at current concentrations <sup>b</sup> (soil)	NA	NA	NA	NA	NA	NE	NE	NE	NE	NE

<b>Receptor</b>	<b>Total ELCR<sup>a</sup></b>	<b>COCs</b>	<b>% Total ELCR</b>	<b>POCs</b>	<b>% Total ELCR</b>	<b>Total HI<sup>a</sup></b>	<b>COCs</b>	<b>% Total HI</b>	<b>POCs</b>	<b>% Total HI</b>
Future adult rural resident at current concentrations <sup>b</sup> (soil)	NE	NE	NE	NE	NE	NE	NE	NE	NE	NE
Future child recreational user at current concentrations <sup>b</sup> (soil)	NA	NA	NA	NA	NA	NE	NE	NE	NE	NE
Future child recreational user at current concentrations <sup>b</sup> (sediment)	NA	NA	NA	NA	NA	NE	NE	NE	NE	NE
Future teen recreational user at current concentrations <sup>b</sup> (soil)	NA	NA	NA	NA	NA	NE	NE	NE	NE	NE
Future teen recreational user at current concentrations <sup>b</sup> (sediment)	NA	NA	NA	NA	NA	NE	NE	NE	NE	NE
Future adult recreational user at current <sup>b</sup> concentrations (soil)	NE	NE	NE	NE	NE	NE	NE	NE	NE	NE
Future adult recreational user at current concentrations <sup>b</sup> (sediment)	NE	NE	NE	NE	NE	NE	NE	NE	NE	NE
Future excavation worker at current concentrations <sup>b</sup>	NE	NE	NE	NE	NE	NE	NE	NE	NE	NE

Note: NA = ELCR not applicable to child and teen cohorts. ELCR for adult is for lifetime exposure and takes into account exposure as child and teen.

Table adapted from SI for the Southwest Groundwater Plume (DOE 2007).

NE = Land use scenario not of concern or land use not evaluated because contact with medium is not possible.

<sup>a</sup>Total ELCR and total HI columns reflect values from the BHHRA completed as part of the Southwest Plume SI.

<sup>b</sup>Only results for subsurface soil collected below 3.05 ms (10 ft) bgs were available for the Storm Sewer. Please see the Southwest Plume SI BHHRA for additional information.

<sup>c</sup>In the FFS BHHRA, only results for use of water drawn from the RGA were calculated.

<sup>d</sup>Information collected during the Southwest Plume SI indicates that Storm Sewer is not a source of contamination to the Southwest Plume.

**OBSERVATIONS.** Specific observations of the BHHRA and SERA are presented here. Consistent with hypothetical rural resident use, observations for source areas focus on risks posed under hypothetical future on-site and off-site residential land use; the observations from the SERA focus on potential future risks.

**BHHRA.** In the BHHRA, it was determined that the hypothetical rural residential use of groundwater scenario and vapor intrusion is of concern for both ELCR and HI at each source area, except the Storm Sewer, which is of concern for ELCR only. For the hypothetical rural resident at the Oil Landfarm, VOC COCs include chloroform; *cis*-1,2-DCE; and TCE, all of which are “Priority COCs” (i.e., chemical-specific HI or ELCR greater than or equal to 1 or  $1 \times 10^{-4}$ ). These VOCs made up 78% of a cumulative ELCR of  $6 \times 10^{-4}$  and 81% of the cumulative HI of 80.

At the C-720 Building Area, the VOC COCs for the hypothetical rural resident include TCE; *cis*-1,2-DCE; *trans*-1,2-DCE; and 1,1-DCE, with all except *trans*-1,2-DCE being “Priority COCs.” These VOCs made up 93% of a cumulative ELCR of  $2 \times 10^{-3}$  and 69% of the cumulative HI of 70. At the Storm Sewer, rural residential COCs included TCE and 1,1-DCE, neither of which was a “Priority COC.” The VOCs made up 100% of a cumulative ELCR of  $8 \times 10^{-6}$ . The HI for the storm sewer was less than 1 and, therefore, not of concern.

For the modeled POEs, the COCs for the hypothetical rural resident at the property boundary from VOCs migrating from the Oil Landfarm are TCE; *cis*-1,2-DCE; *trans*-1,2-DCE; and VC, with only TCE being a “Priority COC.” The total ELCR for the hypothetical resident at the property boundary was  $1.4 \times 10^{-6}$  and the HI was less than 0.1. The COCs for contaminants migrating from the C-720 Building Area to the hypothetical rural resident at the property boundary are TCE; *cis*-1,2-DCE; and VC with no “Priority COCs.” The total ELCR for the hypothetical rural resident at the property boundary from migrating C-720 Building Area VOCs is  $1.2 \times 10^{-6}$  and the HI is  $4 \times 10^{-1}$ .

**SERA.** The SERA, which used results taken from the Baseline Ecological Risk Assessment completed as part of the WAG 27 RI, concluded that a lack of suitable habitat in the industrial setting at the Oil Landfarm and the C-720 Building Area precluded exposures of ecological receptors under current conditions; therefore, it was determined during problem formulation that an assessment of potential risks under current conditions was unnecessary. Results from earlier assessments presented in the WAG 27 (Oil Landfarm) RI (DOE 1999a) are summarized in Table D.6.

In the BERA for Oil Landfarm, two inorganic chemicals of potential ecological concern (COPECs), chromium and zinc, were identified; however, chromium was found at a maximum concentration similar to its background concentration. Neither organic compound nor radionuclide COPECs were identified.

**Table D.6. Summary of Hazard Quotients for Chemicals<sup>a</sup> Posing Potential Future Risks<sup>b,c</sup> to Ecological Receptors**

Location	Receptor	Chemicals of Potential Ecological Concern				
		Cr	Cu	Ni	V	Zn
Oil Landfarm Ditch soil	Plant	16.8	–	–	–	1.3
	Worm	42.0	–	–	–	–
	Shrew	–	–	–	–	–
	Mouse	–	–	–	–	–
	Deer	–	–	–	–	–
C-720 Building Area	Plant	NE	NE	NE	NE	NE
	Worm	NE	NE	NE	NE	NE
	Shrew	NE	NE	NE	NE	NE
	Mouse	NE	NE	NE	NE	NE
	Deer	NE	NE	NE	NE	NE
Storm Sewer	Plant	NE	NE	NE	NE	NE
	Worm	NE	NE	NE	NE	NE
	Shrew	NE	NE	NE	NE	NE
	Mouse	NE	NE	NE	NE	NE
	Deer	NE	NE	NE	NE	NE

Notes: Cr = chromium; Cu = copper; Ni = nickel; V = vanadium; Zn = zinc.

Table adapted from SI for the Southwest Groundwater Plume (DOE 2007).

“–” indicates that the hazard quotient for the chemical/receptor combination did not exceed 1 or the chemical was below background in that sector.

“Northeast” indicates that no evaluation was done. For the C-720 Building Area and Storm Sewer, no evaluation was done because surface soil results were not available due to current ground cover and no data were available, respectively.

<sup>a</sup>The table includes values for those chemicals with a maximum concentration above background (or no background available) and at least one hazard quotient > 1.0. If the hazard quotient was less than one or the maximum concentration was less than background, then the hazard quotient is not presented. Analytes for which ecological benchmarks were not available are shown in the SERA in the Southwest Plume SI.

<sup>b</sup>Values in this table are hazard quotients estimated by dividing the dose to the receptor by the benchmark dose.

<sup>c</sup>These results are for the assessment of potential risks due to exposure to contaminants in surface soil, if the industrial infrastructure were to be removed. These results are a point of reference that can be used in future risk management decisions.